



CLEVELAND ALLIANCES LTD
INDUSTRY AGRICULTURE AMENITY



bravo400S
sele
TRON


**400S BRAVO SERIES COMPUTER
WITH INTEGRATED GPS NAVIGATOR**
FOR INDIVIDUAL NOZZLE CONTROL

4674A9DX0.950

Software rel. 1.0X

INSTALLATION, USE AND MAINTENANCE

 = Generic danger

 = Warning

Cleveland Alliances

This manual is an integral part of the equipment to which it refers and must accompany the equipment in case of sale or change of ownership. Keep it for any future reference; ARAG reserves the right to modify product specifications and instructions at any moment and without notice.


CONTENTS

1	Risks and protections before assembly	5
2	Intended use	5
3	Precautions	5
4	Package content	5
5	Position on farming machine	6
5.1	System recommended composition	6
5.2	Monitor and control unit positioning	9
5.3	Bracket fixing	10
5.4	Control unit (RCU) fixing	10
5.5	Control unit position	10
5.6	Hydraulic unit positioning	10
5.7	GPS receiver positioning	11
6	Wiring connections	13
6.1	General precautions for a correct harness position	13
6.2	Switch box connection	13
6.3	Connecting the Remote Control Units (RCU) (Seletron RCU and hydraulic RCU)	13
6.4	Securing the Seletron cables	14
6.5	Hydraulic valves connection	16
6.6	Sensor connection	17
6.7	Camera connection	17
6.8	Power supply connection	17
6.9	SD memory card	18
6.10	Pen drive	18
7	Setup	19
7.1	Setup preparation	19
7.2	Switching on	19
7.3	Switching off	20
7.4	Use of keys for setup	20
8	Menu structure	21
9	Basic settings	22
10	Advanced setup	24
10.1	Implement - SPRAYER (SELETRON)	26
10.1.1	Spray spots configurations	26
10.1.2	Boom settings	27
	• Spray spots spacing	27
	• Sections number	27
	• Section 1 ÷ 13	27
10.1.3	Flowmeter	28
	• Type	28
	• Constant	28
	• Minimum flowrate	28
	• Maximum flowrate	28
10.1.4	Filling flowmeter	29
	• Activation status	29
	• Type	29
	• Constant	29
	• Minimum flowrate	29
	• Maximum flowrate	29
10.1.5	Pressure sensor	30
	• Activation status	30
	• Type	30
	• Maximum pressure	30
10.1.6	Valves	31
	MAIN VALVE	
	• Type (REMINDER)	31
	• Automatic closing of sections valves (REMINDER)	31
	• Switching time	31
	PRESSURE REGULATING VALVE	
	• Regulation direction	31
	SECTION VALVES	
	• Type (REMINDER)	32
	• Shut-off time	32
	• Switch-on time	32
10.1.7	Nozzles data	33
	• Flowrate	33
	• Pressure	33
	• Minimum pressure	33
	• Maximum pressure	33
10.1.8	Wheel sensor	34
	• Constant	34
10.1.9	Rev counter	34
	• Activation status	34
	• Constant	34
	• Minimum rotation speed	34
	• Maximum rotation speed	34
10.1.10	Tank	35
	• Capacity	35
	• Reserve level	35
10.1.11	Alarms	36
	NOZZLES ALARMS	
	• Nozzle wear check	36
	• Nozzle wear limit percentage	36
	• Minimum pressure alarm	36
	• Maximum pressure alarm	36
	FLOWMETER ALARMS	
	• Minimum flowrate alarm	37
	• Maximum flowrate alarm	37
	REV COUNTER ALARMS	
	• Minimum rotation speed alarm	37
	• Maximum rotation speed alarm	37
10.1.12	Working parameters	38
	SPRAYING LIMITS	
	• Spraying speed limit	38
	• Minimum spraying speed	38
	• Regulation pressure limit	38
	• Minimum regulation pressure	38
	• Flowrate correction factor	38
	AUTOMATIC SECTION CONTROL	
	• Sections overlapping limit	39
	• Perimeter overlapping limit	39
	• Spray closing delay	40
	• Spray opening advance	40
	GUIDANCE	
	• Steering radius	40
10.1.13	Device calibration	41
	SELETRON SYSTEM	
	• Identification numbers reset	41
	SENSORS	
	• Pressure sensor zero value	41
10.1.14	3-point implement geometry settings (SYSTEM WITH 3-POINT HITCH)	42
	• Implement upper view	42
	• Implement rear view	43
10.1.15	Towed implement geometry settings (SYSTEM WITH TOWING HITCH)	44
	• Implement upper view	44
	• Implement rear view	45

10.2 Implement - GPS GUIDANCE MONITOR.....	46	14 "Home" Menu.....	74
10.2.1 Sections configuration.....	46	14.1 F1 Continue last job.....	75
• Sections number.....	46	14.2 F2 Save job.....	76
• Section 1 ÷ 13.....	46	14.3 F3 New job.....	77
10.2.2 Working parameters.....	47	14.4 F4 Memories management.....	78
• Sections overlapping limit.....	47	14.4.1 Internal memory.....	79
• Perimeter overlapping limit.....	47	• Delete.....	79
• Spray closing delay.....	48	• Copy to SD card.....	79
• Spray opening advance.....	48	• Copy to USB Pendrive (1 or 2).....	79
• Steering radius.....	48	14.4.2 SD card.....	80
10.2.3 3-point implement geometry settings (SYSTEM WITH 3-POINT HITCH).....	49	• Delete.....	80
• Implement upper view.....	49	• Copy to internal memory.....	80
• Implement rear view.....	50	• Remote devices upgrade.....	81
10.2.4 Towed implement geometry settings (SYSTEM WITH TOWING HITCH).....	51	• Export job in "Shape" format.....	82
• Implement upper view.....	51	14.4.3 USB Pendrive.....	83
• Implement rear view.....	52	• Delete.....	83
10.3 Tractor.....	53	• Copy to internal memory.....	83
10.3.1 DGPS.....	53	• Remote devices upgrade.....	84
10.3.2 PDOP / HDOP alarm.....	53	• Export job in "Shape" format.....	85
10.3.3 Camera.....	53	14.5 F5 Resume job.....	86
10.3.4 Tractor geometry settings.....	54	14.6 F6 Info / Alarms.....	87
• Tractor upper view.....	54	15 Job menu.....	88
• Tractor rear view.....	54	15.1 F1 Info / Alarms.....	89
• Steering angle.....	54	15.2 F2 Work data.....	90
10.4 User.....	55	15.3 F3 Tank.....	91
10.4.1 Acoustic alarms.....	55	15.4 F4 GPS Data.....	92
10.4.2 Acoustic warnings.....	55	15.5 F5 Camera.....	93
10.4.3 Acoustic info.....	55	15.6 F6 Prescription map.....	94
10.4.4 Steering warning.....	55	15.7 F7 Zoom all.....	95
10.5 General options.....	56	15.8 F8 Menu.....	96
10.5.1 Language.....	56	15.8.1 Speed source.....	96
10.5.2 Units of measurement.....	56	• GPS.....	96
10.5.3 Date and time GPS updating.....	57	• Wheel sensor.....	96
10.5.4 Timezone.....	57	• Simulation.....	96
10.5.5 Date and time.....	57	16 Job functions.....	97
10.6 Device status - SPRAYER (SELETRON).....	58	16.1 F1 Spray rate.....	98
Status of the Seletron system.....	58	16.2 F2 Guidance mode.....	99
External signals.....	58	16.3 F3 Pause.....	100
Power data.....	58	16.4 F4 Surface.....	101
Firmware versions.....	58	16.5 F5 Resume from pause.....	102
10.7 Device status - GPS GUIDANCE MONITOR.....	60	16.6 F6 Align.....	103
External signals.....	60	16.7 F7 New AB.....	104
Power data.....	60	16.8 F8 Display.....	105
Firmware versions.....	60	16.8.1 F2 Tractor themes.....	105
11 Seletron connection.....	61	16.8.2 F4 Spraying themes.....	106
12 Use.....	63	16.8.3 F6 Daytime/night time display mode.....	106
12.1 Controls on computer.....	63	16.8.4 F8 2D/3D display mode.....	106
12.2 Operating switches for control unit valves.....	64	17 Maintenance / diagnostics / repairs.....	107
12.3 Operating switches for hydraulic valves.....	64	17.1 Error messages.....	107
12.4 Guidance screen.....	65	17.2 Troubleshooting.....	109
12.5 Spraying a field.....	66	17.3 Cleaning rules.....	109
13 Automatic functions.....	68	18 Technical data.....	110
13.1 Output adjustment.....	69	18.1 The data and unit of measurement shown.....	110
13.2 F2 Automatic adjustment ON/OFF.....	69	19 End-of-life disposal.....	114
13.3 Importing and using a prescription map.....	69	20 Guarantee terms.....	114
13.4 How the automatic nozzle selection works (SELETRON system).....	70		
13.5 F4 Automatic nozzle selection ON/OFF.....	71		
13.6 F1/F3/F5/F7 Manual nozzle selection.....	71		
13.7 Boom section management.....	72		
13.8 F6 Automatic section management ON/OFF.....	73		

1 RISKS AND PROTECTIONS BEFORE ASSEMBLY

All installation works must be done with battery disconnected, using suitable tools and any individual protection equipment deemed necessary.

 Use **ONLY** clean water for treatment tests and simulations: using chemicals during simulated treatment runs can seriously injure persons in the vicinity.

2 INTENDED USE

The device you have purchased is a computer which, when connected to a valve or suitable control unit, makes it possible to control all phases of treatment in agricultural applications directly from the cabin of the farming machine it is installed in.


BRAVO 400S features a satellite navigator that – through the external GPS receiver – can be used for agricultural applications and navigation.

 BRAVO 400S is not designed for use on public roads and should only be used on farmland.

This device is designed to work on agricultural machinery for spraying and crop spraying applications.

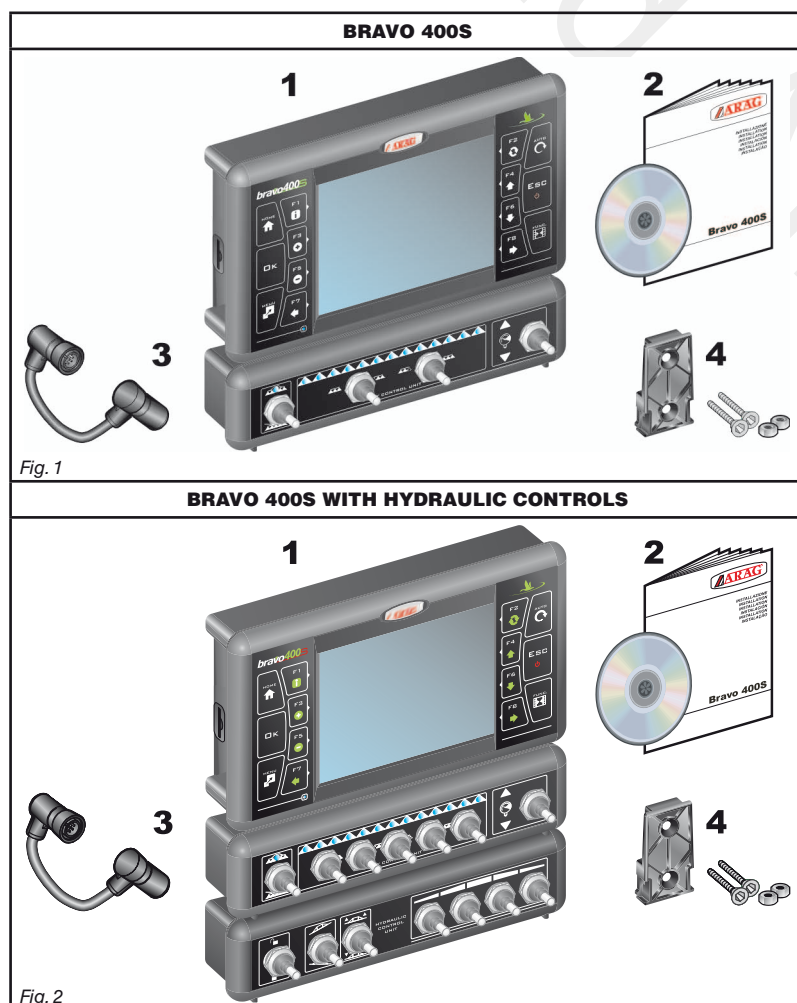
The machine is designed and built in compliance with EN ISO 14982 standard (Electromagnetic compatibility - Forestry and farming machines), harmonized with 2004/108/EC Directive.

3 PRECAUTIONS

-  Do not aim water jets at the equipment.
 - Do not use solvents or fuel to clean the case outer surface.
 - Do not clean equipment with direct water jets.
 - Comply with the specified power voltage (12 Vdc).
 - In case of voltaic arc welding, remove connectors from BRAVO 400S and disconnect the power cables.
 - Only use ARAG genuine spare parts and accessories.
 - Bravo 400S can control hydraulic valves to open / close the boom.
- The computer does not feature emergency stop devices: the manufacturer must provide all necessary safety devices for the hydraulic boom control.
- Any time one hydraulic boom section is opened or closed the computer emits an acoustic signal and the display shows the relevant indication. The manufacturer should also provide acoustic and optical warnings in the vicinity of the boom.

4 PACKAGE CONTENT

The diagram below indicates the components that you will find in the BRAVO 400S computer package:



Legend:

- 1** Bravo 400S
- 2** Instruction manual
- 3** Monitor - switch box connection cable
- 4** Fixing kit

 To be ordered separately:
Seletron RCU / RCU for hydraulic controls

5.1 System recommended composition

! Connect the power cable directly to the battery wires using the suitable eyelets.
WARNING! DO NOT connect to key-operated switch (15/54).

To connect all parts of the system correctly, make sure to use the proper connection cables specified in Tab. 1 page 8.

Consider all possible variants:

- type of system,
- type of Seletron units connected (single, twin or fourfold)
- number of nozzles per mechanical arm (of spraying boom)

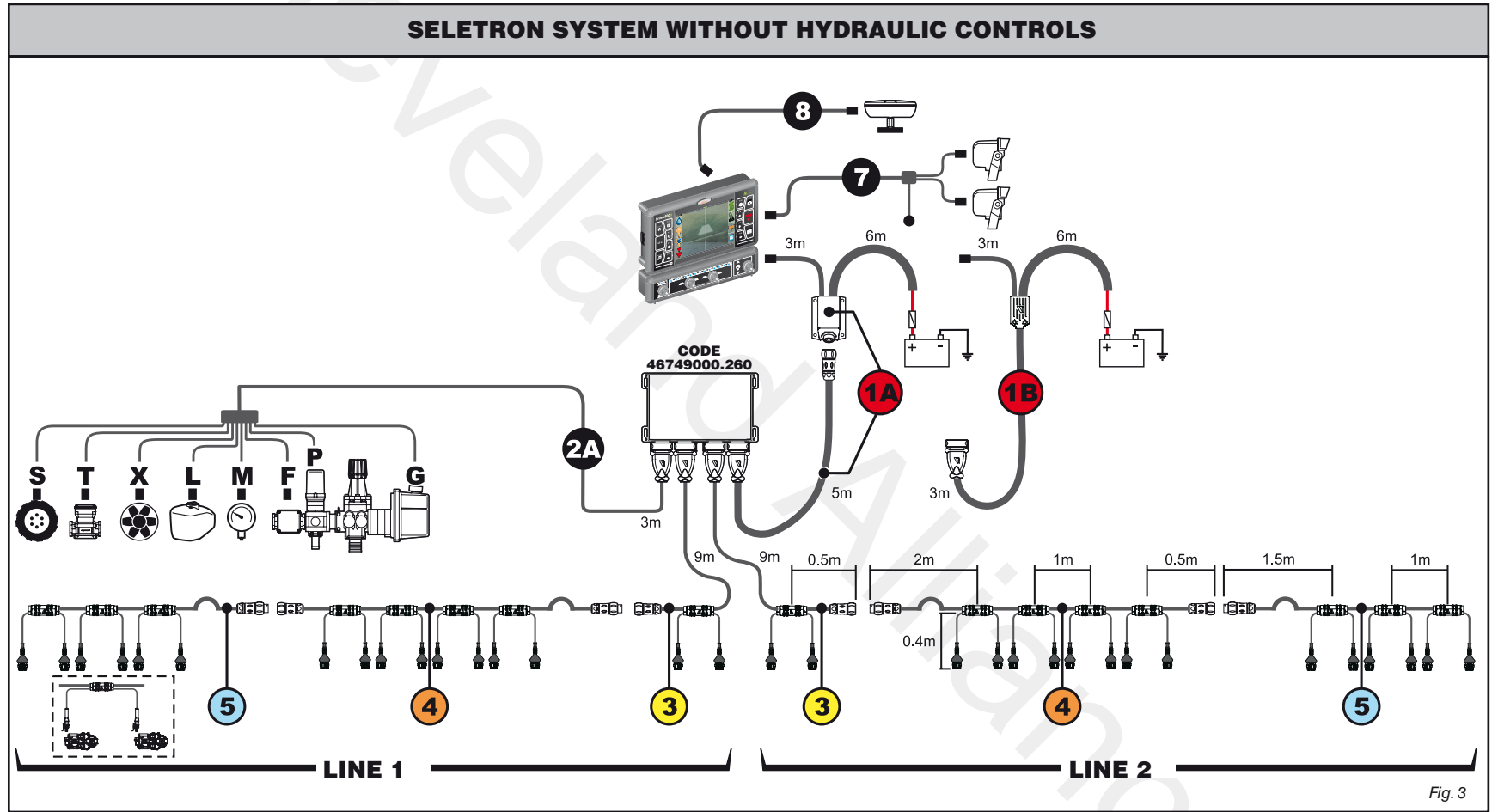
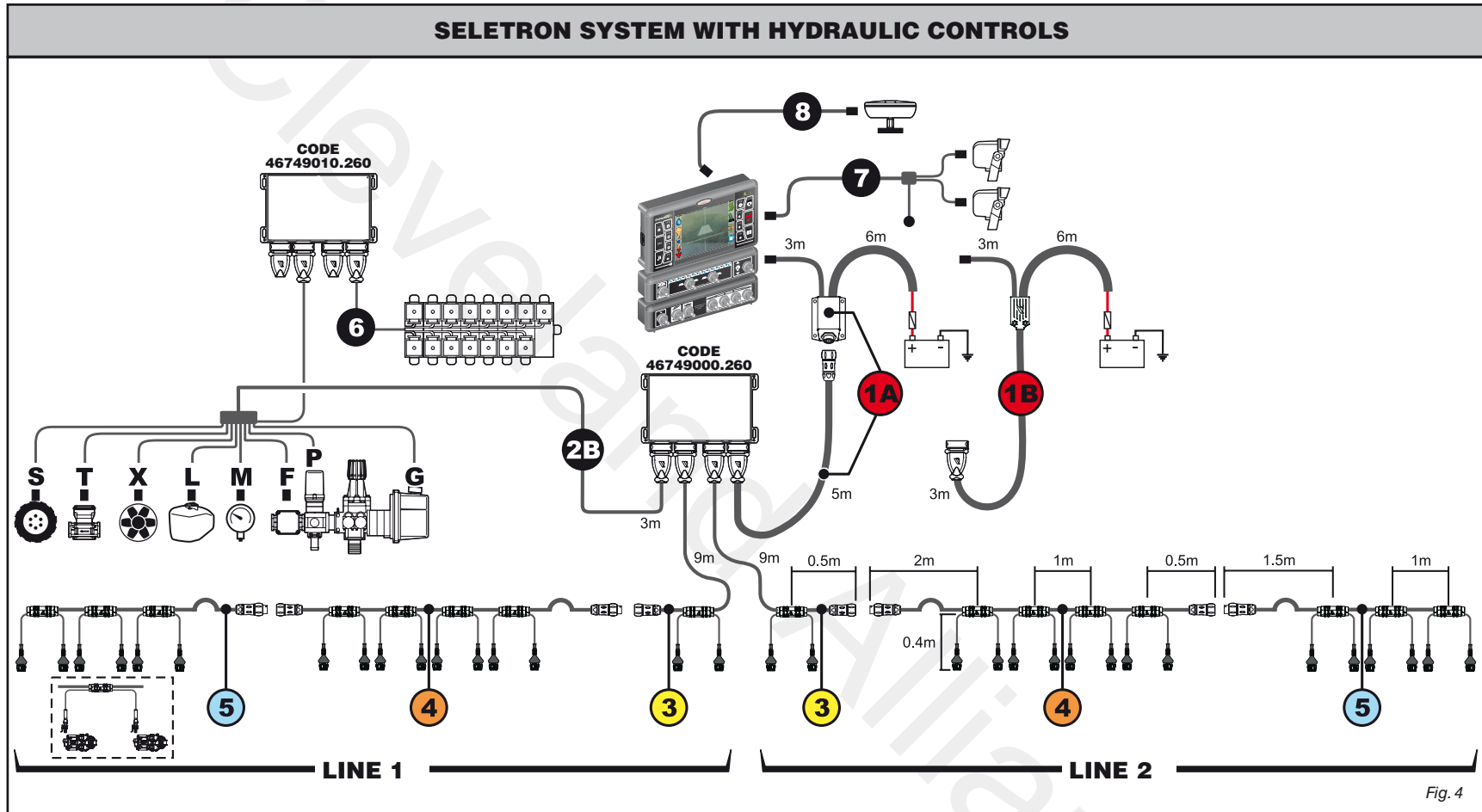


Fig. 3

Legend of connection cables:

- | | |
|--|----------------------------|
| 1A Computer / RCU / battery for TRAILED MACHINE | S Speed sensor |
| 1B Computer / RCU / battery for SELF-PROPELLED MACHINE | T Filling flowmeter |
| 2A Control unit / sensors | X RPM sensor |
| 3 Head-end cable | L Level sensor |
| 4 Extension cable | M Pressure sensor |
| 5 Termination cable | F Flowmeter |
| 7 Cameras / external main control | P Control valve |
| 8 GPS receiver | G Main valve |



Legend of connection cables:

- 1A** Computer / RCU / battery for **TRAILED MACHINE**
- 1B** Computer / RCU / battery for **SELF-PROPELLED MACHINE**
- 2B** Control unit / sensors / hydraulic RCU
- 3** Head-end cable
- 4** Extension cable
- 5** Termination cable
- 6** Hydraulic unit
- 7** Cameras / external main control
- 8** GPS receiver

- S** Speed sensor
- T** Filling flowmeter
- X** RPM sensor
- L** Level sensor
- M** Pressure sensor
- F** Flowmeter
- P** Control valve
- G** Main valve



**STANDARD CABLES
FOR SELETRON - SINGLE
MAX. BOOM WIDTH 48 M
50 cm spacing**



**STANDARD CABLES
FOR SELETRON - TWIN
MAX. BOOM WIDTH 24 M
50 cm spacing**



**PLUS CABLES
FOR SELETRON - TWIN
MAX. BOOM WIDTH 36 M
50 cm spacing**

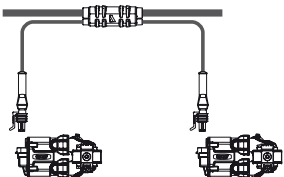


**PLUS CABLES
FOR SELETRON - FOURFOLD
MAX. BOOM WIDTH 36 M
50 cm spacing**

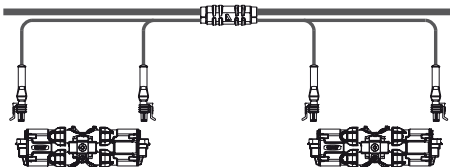
Connection cable for MONITOR /
REMOTE CONTROL UNIT - BATTERY

1B	467 49000.150	Cable for TRAILED M/C
1A	467 49000.100	Cable for SELF-PROPELLED M/C
2A	467 49000.110	Connection cable control unit / sensors
2B	467 49010.110	Connection cable control unit / sensors / hydraulic RCU

The cables for single and twin
SELETRON feature 2 outputs per joint.



The cables for fourfold SELETRON
feature 4 outputs per joint.



3 - STANDARD CENTRAL CABLES

Code	no. of SELETRON nozzle holders	Cable length (m)
467 491 A020.100	2	9.5
467 491 A031.100	3	10.5

**4 - STANDARD EXTENSION
CABLES**

Code	no. of SELETRON nozzle holders	Cable length (m)
467 492 A031.100	3	3.5
467 492 A041.100	4	3.5
467 492 A051.100	5	4.5
467 492 A061.100	6	4.5
467 492 A071.100	7	5.5
467 492 A081.100	8	5.5
467 492 A091.100	9	6.5
467 492 A101.100	10	6.5
467 492 A111.100	11	7.5
467 492 A121.100	12	7.5
467 492 A131.100	13	8.5
467 492 A141.100	14	8.5
467 492 A151.100	15	9.5
467 492 A161.100	16	9.5
467 492 A171.100	17	10.5
467 492 A181.100	18	10.5
467 492 A191.100	19	11.5
467 492 A201.100	20	11.5

**5 - STANDARD TERMINATION
CABLES**

Code	no. of SELETRON nozzle holders	Cable length (m)
467 493 A031.100	3	2.5
467 493 A041.100	4	2.5
467 493 A051.100	5	3.5
467 493 A061.100	6	3.5
467 493 A071.100	7	4.5
467 493 A081.100	8	4.5

3 - STANDARD CENTRAL CABLES

Code	no. of SELETRON nozzle holders	Cable length (m)
467 491 A020.100	2	9.5
467 491 A031.100	3	10.5

**4 - STANDARD EXTENSION
CABLES**

Code	no. of SELETRON nozzle holders	Cable length (m)
467 492 A031.100	3	3.5
467 492 A041.100	4	3.5
467 492 A051.100	5	4.5
467 492 A061.100	6	4.5
467 492 A071.100	7	5.5
467 492 A081.100	8	5.5
467 492 A091.100	9	6.5
467 492 A101.100	10	6.5
467 492 A111.100	11	7.5
467 492 A121.100	12	7.5

**5 - STANDARD TERMINATION
CABLES**

Code	no. of SELETRON nozzle holders	Cable length (m)
467 493 A031.100	3	2.5
467 493 A041.100	4	2.5
467 493 A051.100	5	3.5
467 493 A061.100	6	3.5

3 - PLUS CENTRAL CABLES

Code	no. of SELETRON nozzle holders	Cable length (m)
467 491 C020.100	2	9.5
467 491 C031.100	3	10.5

4 - PLUS EXTENSION CABLES

Code	no. of SELETRON nozzle holders	Cable length (m)
467 492 C031.100	3	3.5
467 492 C041.100	4	3.5
467 492 C051.100	5	4.5
467 492 C061.100	6	4.5
467 492 C071.100	7	5.5
467 492 C081.100	8	5.5
467 492 C091.100	9	6.5
467 492 C101.100	10	6.5
467 492 C111.100	11	7.5
467 492 C121.100	12	7.5
467 492 C131.100	13	8.5
467 492 C141.100	14	8.5
467 492 C151.100	15	9.5
467 492 C161.100	16	9.5
467 492 C171.100	17	10.5
467 492 C181.100	18	10.5
467 492 C191.100	19	11.5
467 492 C201.100	20	11.5

5 - PLUS TERMINATION CABLES

Code	no. of SELETRON nozzle holders	Cable length (m)
467 493 C031.100	3	2.5
467 493 C041.100	4	2.5
467 493 C051.100	5	3.5
467 493 C061.100	6	3.5
467 493 C071.100	7	4.5
467 493 C081.100	8	4.5

3 - PLUS CENTRAL CABLES

Code	no. of SELETRON nozzle holders	Cable length (m)
467 491 D020.100	2	9.5
467 491 D031.100	3	10.5

4 - PLUS EXTENSION CABLES

Code	no. of SELETRON nozzle holders	Cable length (m)
467 492 D031.100	3	3.5
467 492 D041.100	4	3.5
467 492 D051.100	5	4.5
467 492 D061.100	6	4.5
467 492 D071.100	7	5.5
467 492 D081.100	8	5.5
467 492 D091.100	9	6.5
467 492 D101.100	10	6.5
467 492 D111.100	11	7.5
467 492 D121.100	12	7.5
467 492 D131.100	13	8.5
467 492 D141.100	14	8.5
467 492 D151.100	15	9.5
467 492 D161.100	16	9.5
467 492 D171.100	17	10.5
467 492 D181.100	18	10.5
467 492 D191.100	19	11.5
467 492 D201.100	20	11.5

5 - PLUS TERMINATION CABLES

Code	no. of SELETRON nozzle holders	Cable length (m)
467 493 D031.100	3	2.5
467 493 D041.100	4	2.5
467 493 D051.100	5	3.5
467 493 D061.100	6	3.5
467 493 D071.100	7	4.5
467 493 D081.100	8	4.5

5.2 Monitor and control unit positioning

The BRAVO 400S series computer must be placed in the control cabin of the farming machine. Observe the following precautions:

- Do NOT install the monitor in areas where it would be subjected to excessive vibrations or shocks, to prevent any damage or accidental use of the control keys;
- Install the device in a visible position within easy reach by hand; bear in mind that the monitor should not obstruct the operator's freedom of movement or block his view.

Control units (RCU): secure the control units on the back of the machine, close to the control unit and the hydraulic unit.

Consider all necessary connections of the computer (Fig. 5 and Fig. 6), the cable length, and make sure there is enough space for connectors and cables.

An identification symbol is located next to each connector to indicate its function. For any reference to the system configuration read par. 5.1.

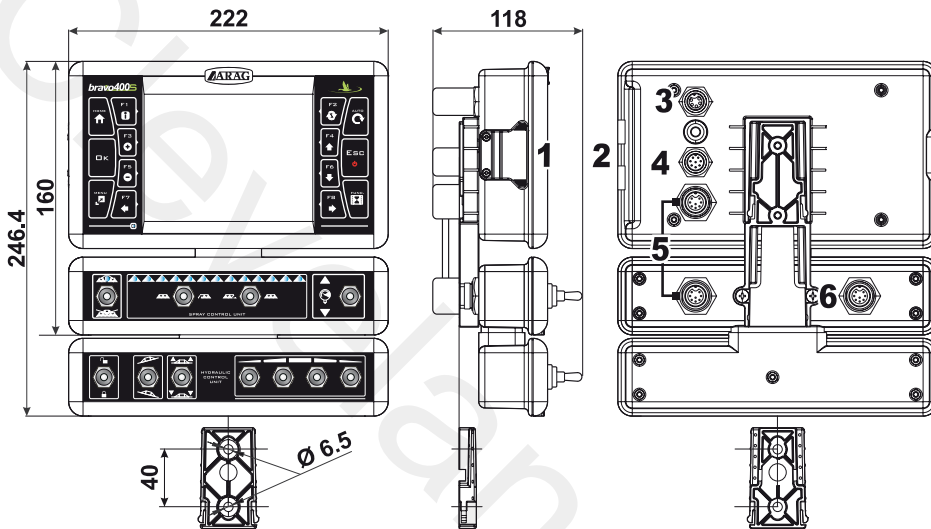


Fig. 5

ITEM	CONNECTION POINTS	
MONITOR	1	SD memory card
	2	USB (2)
	3	GPS receiver
	4	Cameras + External main control
	5	Connection monitor / switch box
	6	Control panel power supply + RCU connection
RCU SELETRON	7	Control unit (G + P) + Sensors + Connection to hydraulic RCU
	8	Seletron - Line 1
	9	Seletron - Line 2
	10	Monitor + power supply
RCU HYDRAULIC	11	Connection to Seletron RCU
	12	Connection to Hydraulic unit

SELETRON RCU

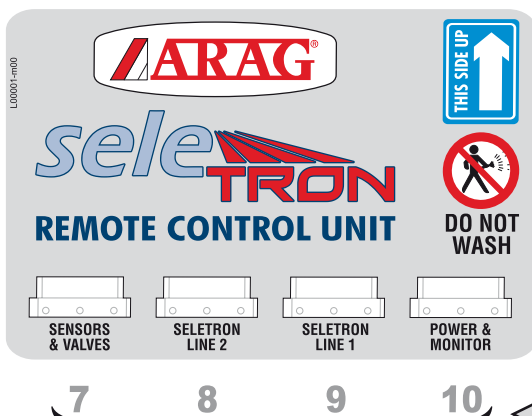
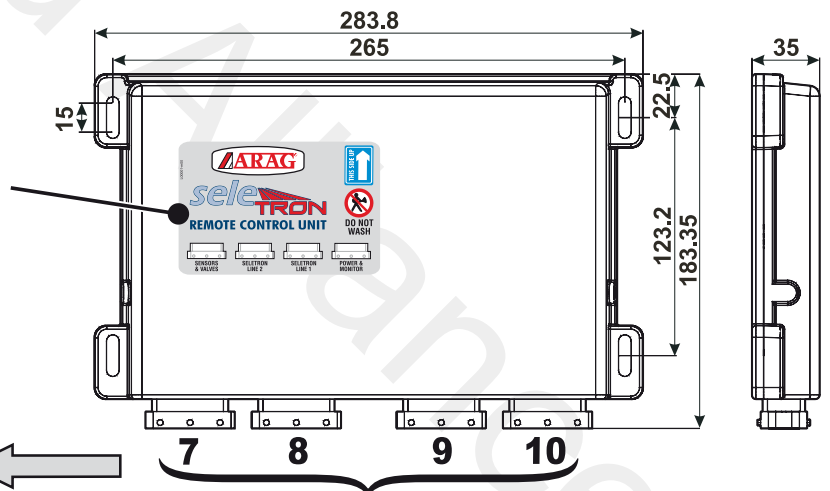


Fig. 6



HYDRAULIC RCU

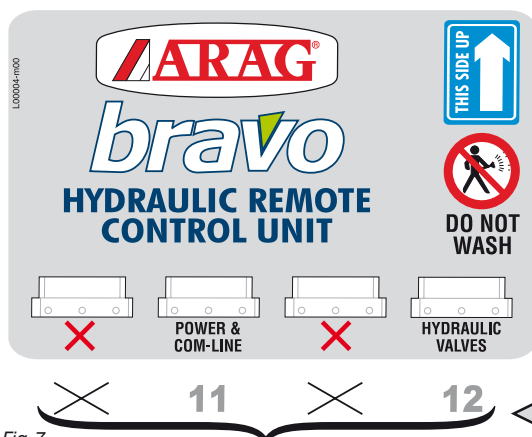
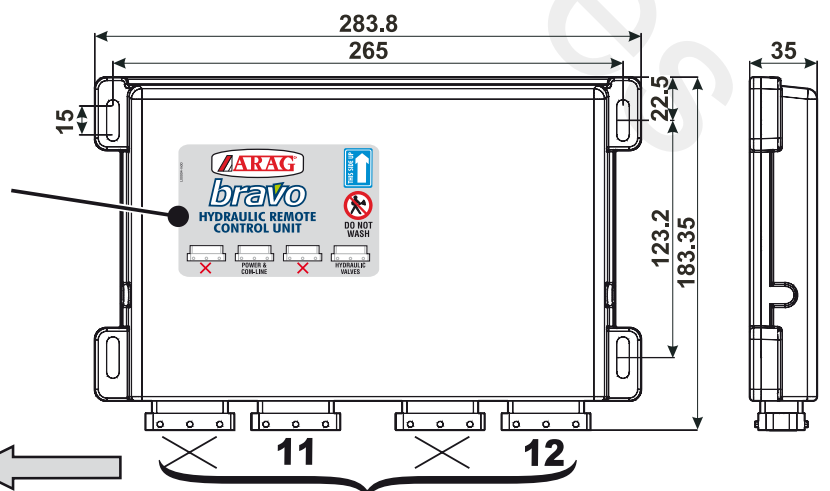


Fig. 7



5.3 Bracket fixing

The monitor must be mounted after having fixed the bracket at the desired location (the previous paragraph shows the bracket drilling template). The bracket must be slid out of the monitor seat (A, Fig. 8) and fixed using the supplied screws (B). Make sure the bracket is securely mounted, fit the monitor on it, and push it until it locks in place (C).

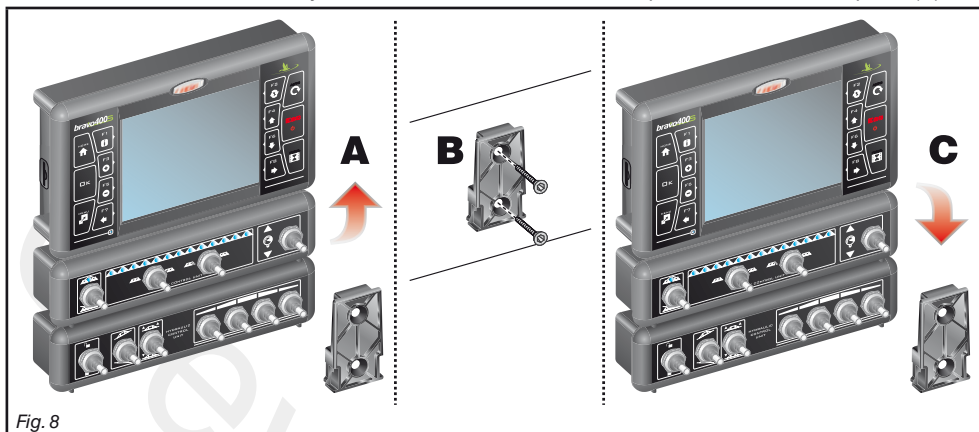


Fig. 8

5.4 Control unit (RCU) fixing

Respect the mounting direction of the control units, as specified in Fig. 9 (connectors shall be facing down).



No other type of assembly is allowed.

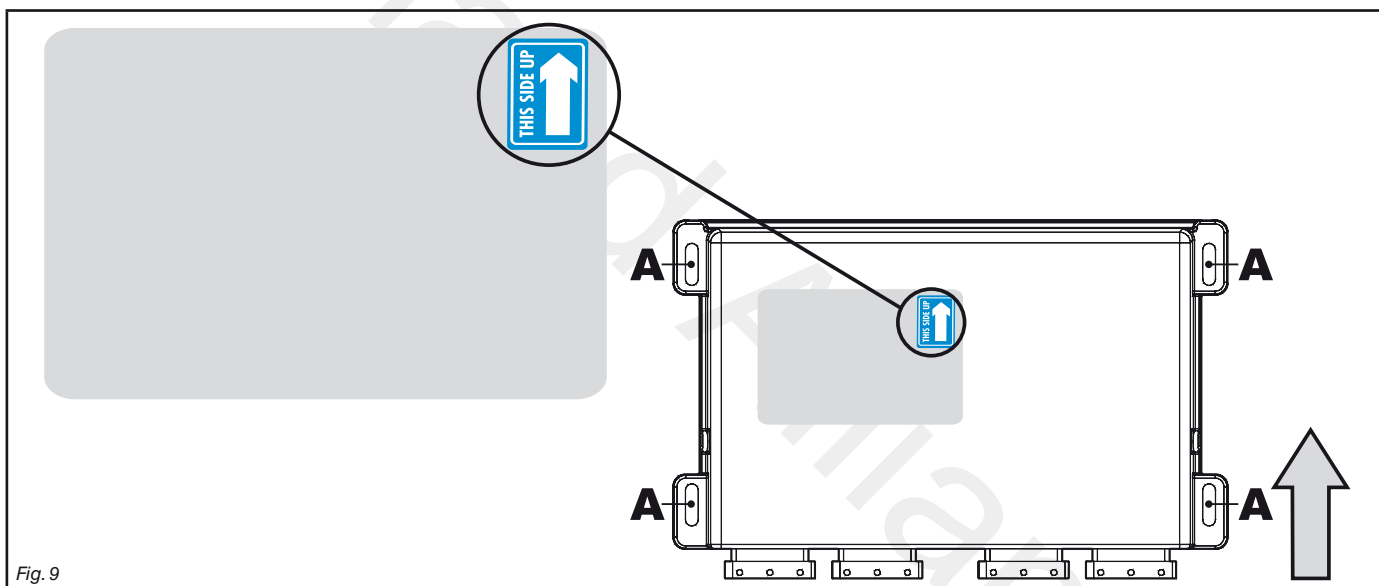


Fig. 9

5.5 Control unit position

The control unit must be fixed with the special brackets supplied and fitted to the unit, positioning it as shown in the manual provided with the assembly.



MAKE SURE TO FOLLOW ALL THE SAFETY INSTRUCTIONS GIVEN IN THE CONTROL UNIT'S MANUAL.

5.6 Hydraulic unit positioning

The hydraulic unit shall be secured to the machine, making sure it is well protected against the elements and the fluid sprayed by the machine.




ARAG IS NOT LIABLE FOR ANY DAMAGE RESULTING FROM THE INSTALLATION BY UNSKILLED PERSONNEL. ANY SYSTEM DAMAGE CAUSED BY A WRONG INSTALLATION AND/OR CONNECTION AUTOMATICALLY VOIDS THE WARRANTY.



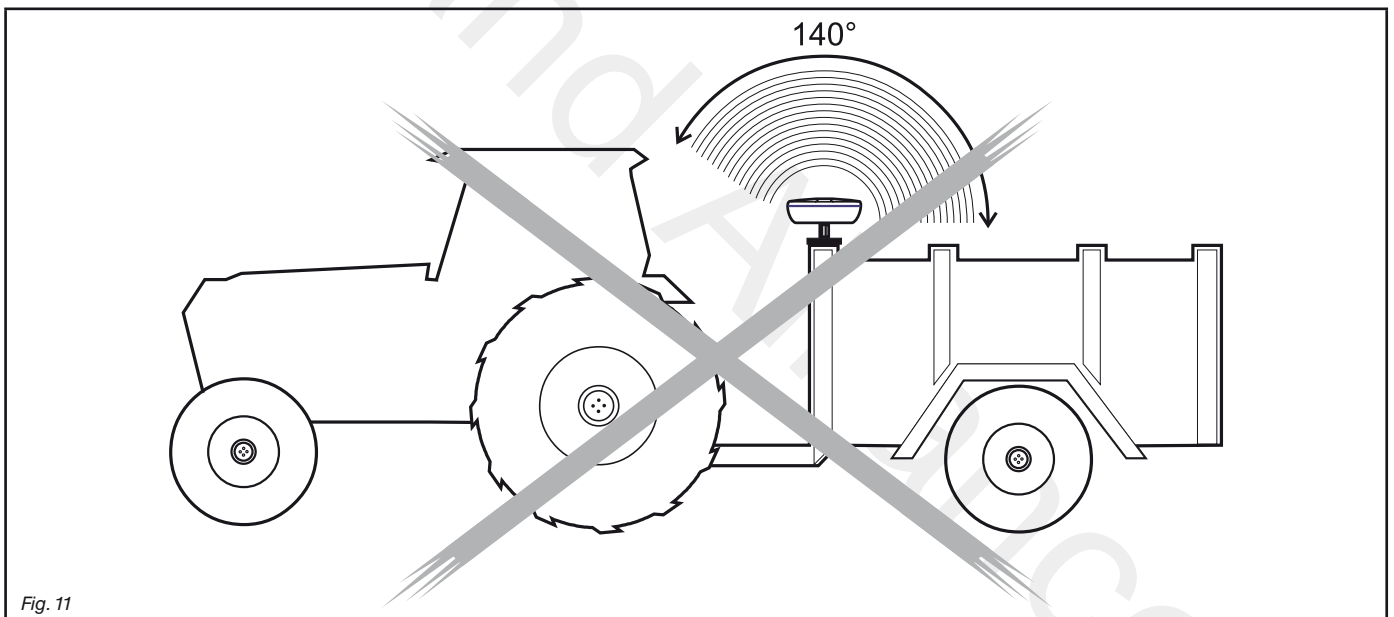
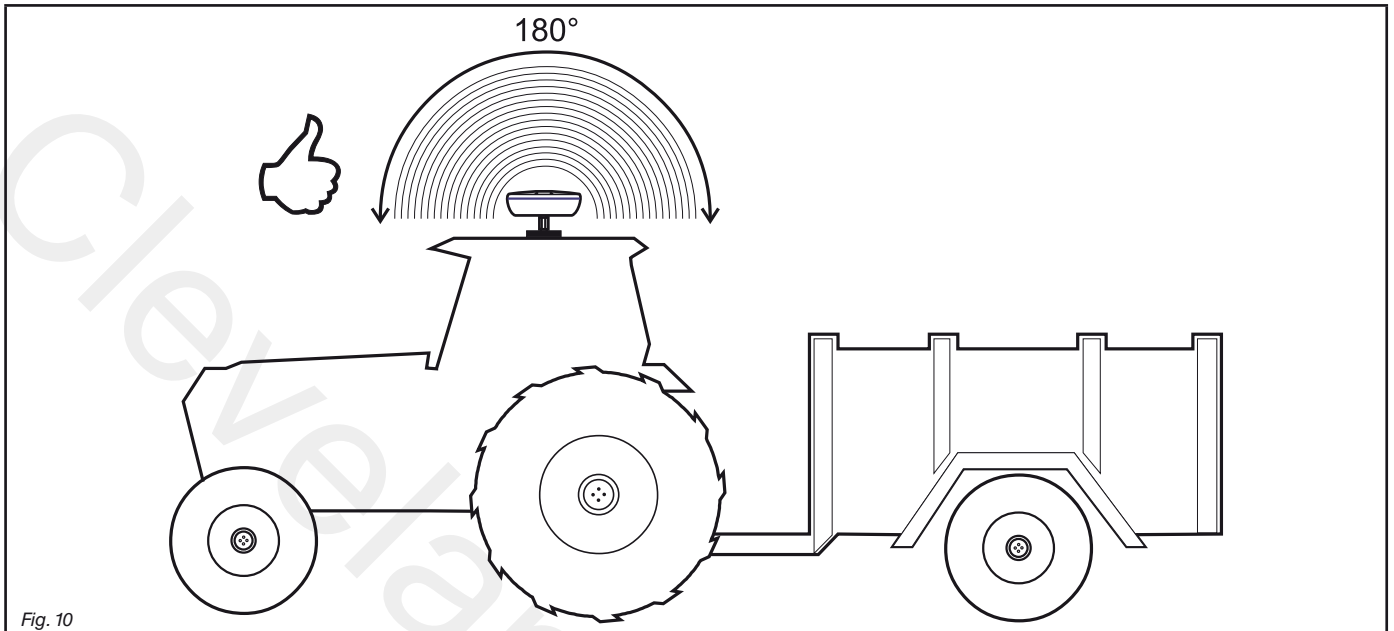
WARNING! DO NOT CONNECT HYDRAULIC UNITS OTHER THAN THE SPECIFIED ONES (SEE ARAG GENERAL CATALOGUE). ARAG IS NOT LIABLE FOR ANY DAMAGE TO THE PRODUCT, MALFUNCTION ERRORS AND ANY KIND OF RISK IF THE MODULE IS CONNECTED TO NON ORIGINAL UNITS OR UNITS NOT SUPPLIED BY ARAG.

5.7 GPS receiver positioning

 The user must position the GPS receiver correctly as specified in this manual and properly account for the greater obstacle clearance height of the vehicle.

GPS receiver installation:

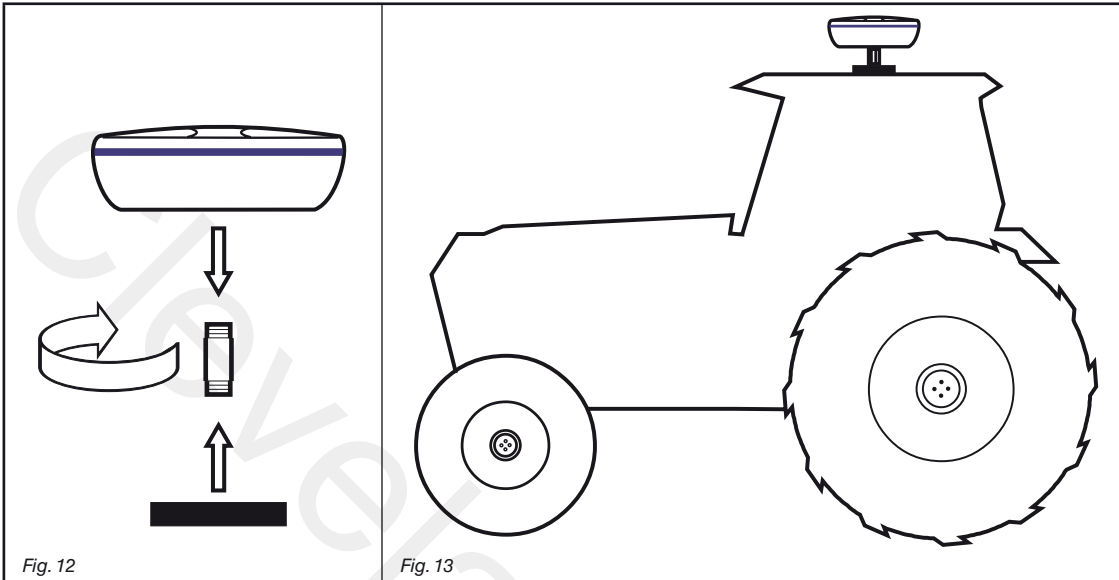
There are certain essential requirements to be met when installing the GPS receiver on the farming machine: it must be mounted on the highest point of the vehicle (including the trailer); angle of reception in the skyward direction should be as wide as possible.



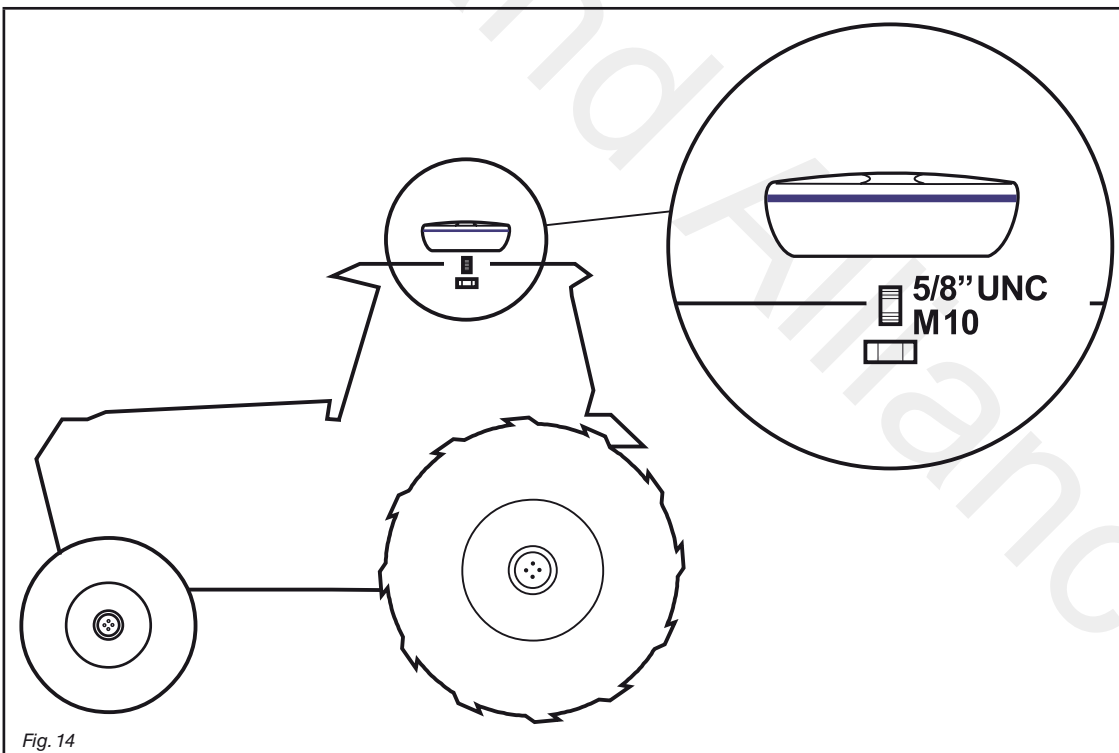
GPS receiver fixing:

If you are using an iron or steel support to fix the receiver, use the supplied magnetic plate. Screw the receiver onto the threaded pin of the plate and tighten until locking it in place (Fig. 12).

⚠ It is important that the receiver be positioned on a perfectly flat metal surface with no coating that could prevent the magnetic plate from holding.



If you are not sure whether the magnetic plate will hold on to the machine, it is best to fix the threaded pin directly to the chassis as shown in Fig. 14: drill a hole and secure the pin with an M10 nut from the inside.



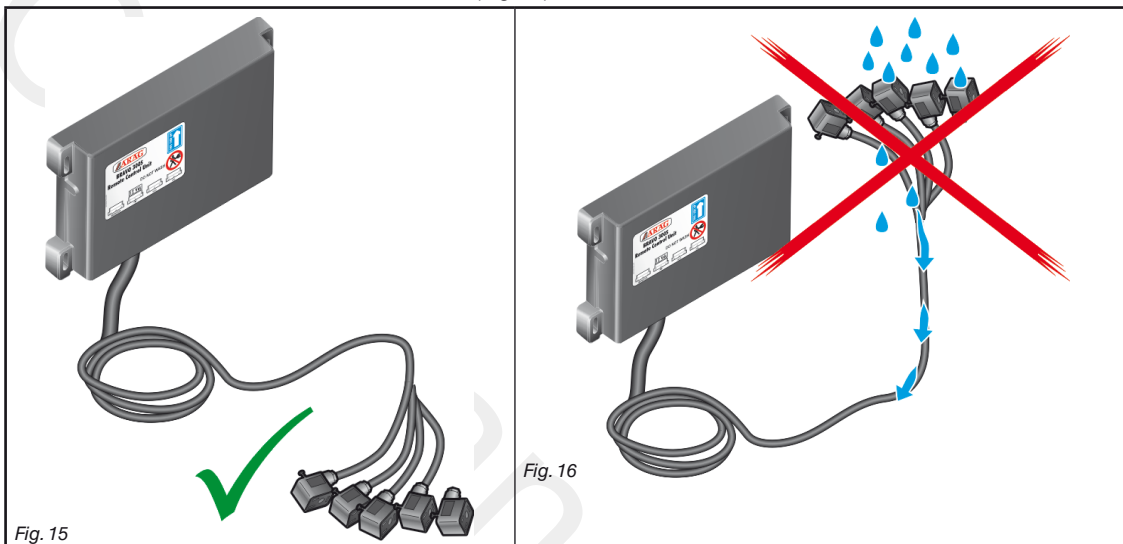
⚠ It is the operator's responsibility to ensure that the system is fixed securely in place. ARAG is not liable for any damage in the event the receiver should come off, regardless of the fixing method used.

6 WIRING CONNECTIONS

- ⚠ • Use only the cables provided with the ARAG computers.
- Take care not to break, pull, tear or cut the cables.
- Use of unsuitable cables not provided by ARAG automatically voids the warranty.
- ARAG is not liable for damages to the equipment, persons or animals caused by failure to observe the above instructions.

6.1 General precautions for a correct harness position

- **Securing the cables:**
 - secure the harness so that it does not interfere with moving parts;
 - route the harnesses so that they cannot be damaged or broken by machine movements or twisting.
- **Routing the cables to protect against water infiltrations:**
 - the cable branches must ALWAYS be face down (Fig. 15).



- **Fitting the cables to the connection points:**
 - do not force the connectors by pushing too hard or bending them: the contacts may be damaged and computer operation may be compromised.

🖐 Use **ONLY** the cables and accessories indicated in the catalogue, having technical features suitable for the use to be made of them.

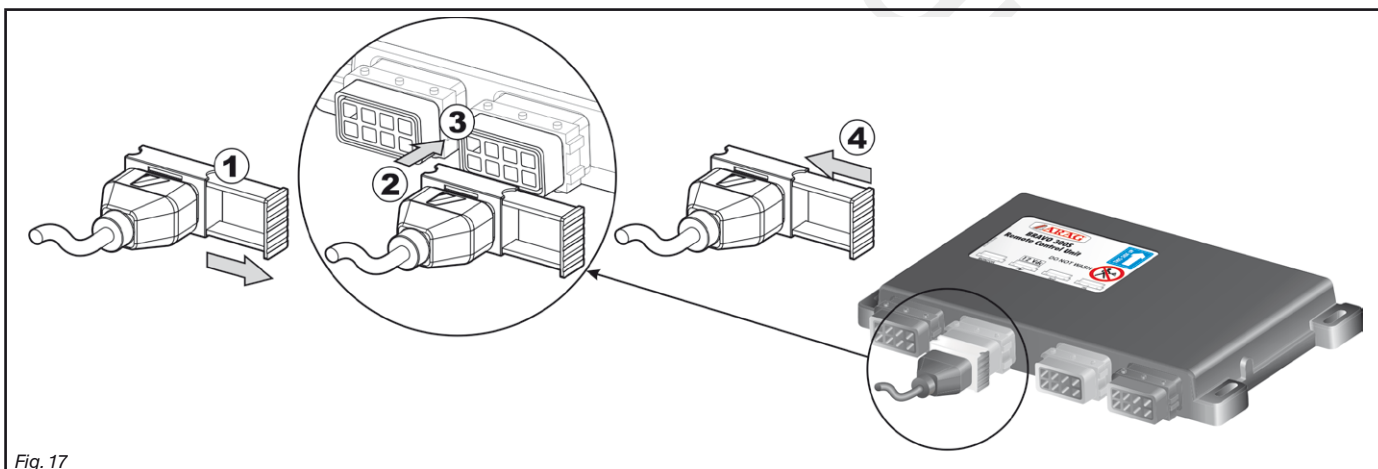
6.2 Switch box connection

The package includes the cable to connect switch box and monitor (component 3, Fig. 1 and Fig. 2). Fit the connectors (see connection points at par. 5.2), ensure they are correctly in place and turn the ring nut clockwise until blocking them.

6.3 Connecting the Remote Control Units (RCU) (Seletron RCU and hydraulic RCU)

Connect harnesses as specified in par. 5.2; each one of them shall be connected to the corresponding socket on the remote control unit.

🖐 If they prove hard to insert, do not force them, but check the shown position.



- Open connector slide (1, Fig. 17).
- To position connector (2), insert it inside socket (3), then press: **during this operation, take care not to bend the electric contacts.**
- Close slide (4) until it locks in place.

6.4 Securing the Seletron cables

WARNING! DO NOT CONNECT THE CONNECTORS TO THE SELETRON NOZZLE HOLDERS. THE SELETRON ELECTRIC CONNECTORS MUST BE CONNECTED AT A LATER TIME, AFTER SETUP (chap. 11 Seletron connection).

Route the cable following these rules:

1 The Seletron units are connected to the RCU (Fig. 18) via two main wiring harnesses (**1** and **2**), each made up of three types of cables: head-end cable (**3**), extension cable (**4**) and termination cable (**5**); the termination cable is indispensable in order to close circuit. **The system will not operate without a termination cable.**

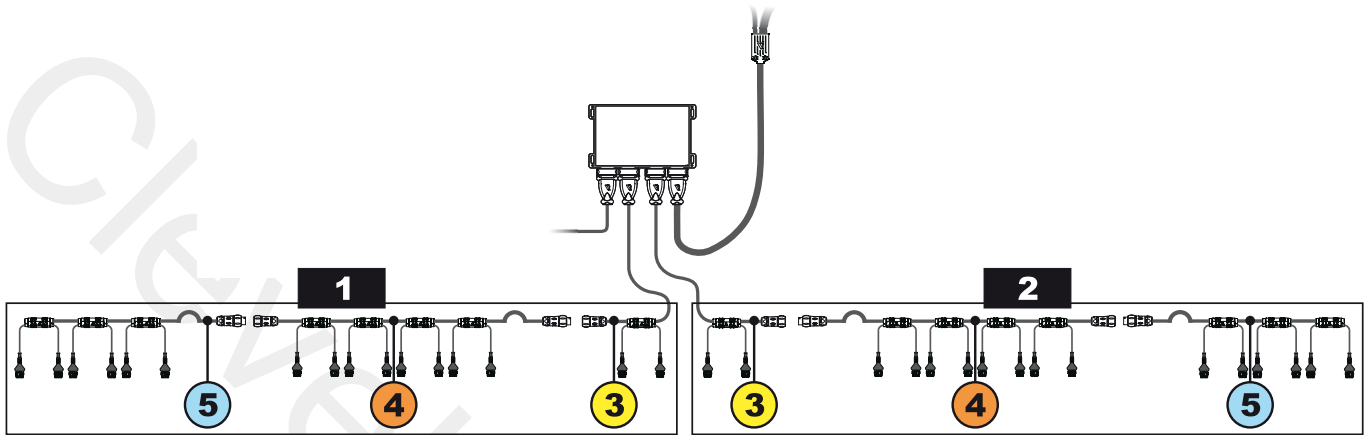


Fig. 18

Consider all necessary connections of the Seletron system, the cable length, and make sure there is enough space for connectors and cables. Secure the cables with ties to protect them from damage.

Thanks to the modular concept of the system, additional **EXTENSION** cables can be added to the circuit to connect additional nozzle holders and obtain the desired boom length.

To ensure proper operation of the system, observe the wiring diagram and use **ONLY** dedicated cables for the type of Seletron installed (Tab. 1 - CONNECTION CABLES page 8).

WARNING! THE CABLES DESIGNED FOR CONNECTING TWIN SELETRON UNITS ON BOOMS UP TO 24 M LONG SHOULD NEVER BE USED ON LONGER BOOMS.

2 RCUs, main control valve, flowmeter and pressure sensor must be installed in the front section of the machine; if needed, **ONLY** the sensors may be moved to a different position and connected using the extensions listed in the catalogue.

Never use an extension for any other components unless you have so agreed with the ARAG Assistance Center.

3 Choose and install the cables so that they retain some freedom of movement at boom joints.

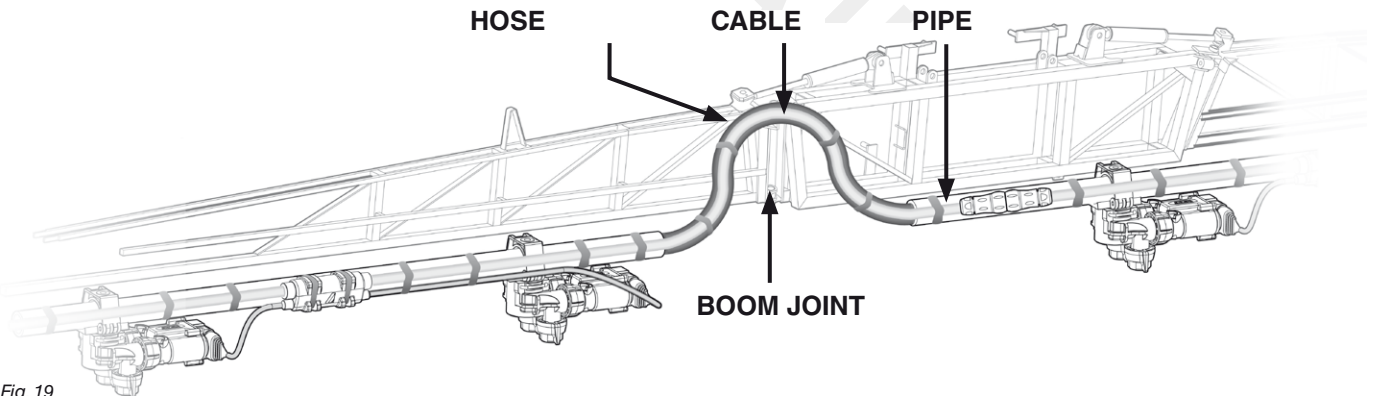


Fig. 19

4 ALWAYS secure the main cable connections (**3**, **4** and **5**) to a stationary section of the boom; the head-end cable is longer than the termination to facilitate this.

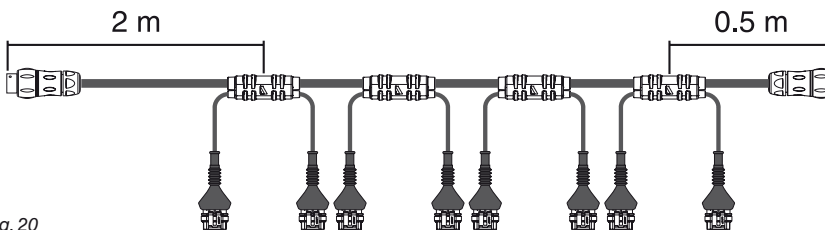


Fig. 20

5 Account for any possible boom movement when positioning and fixing the cables.

6 Carefully check that no connections or branches are positioned near moving parts and high enough to clear possible obstacles on the ground. Ensure that the Seletron nozzle holders do not become jammed with one another or touch any cables or delicate system areas when the boom is closed or folded away.

7 If space is limited and you need to bend a cable, be sure not to bend it too tight or it may damage.

OK

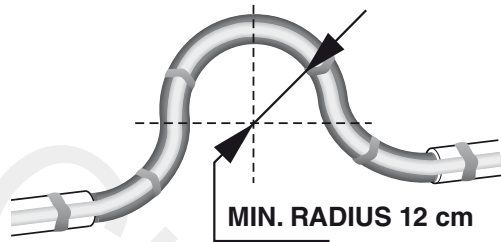
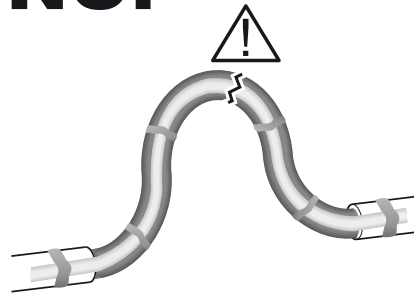


Fig. 21

NO!



8 Position the cable so that branches **A** are equally spaced from Seletron connectors **B**.

NO!

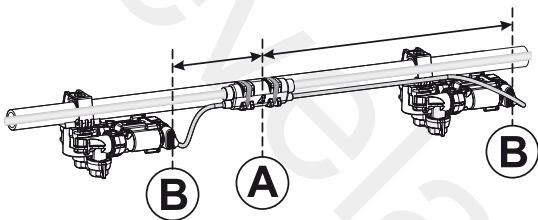
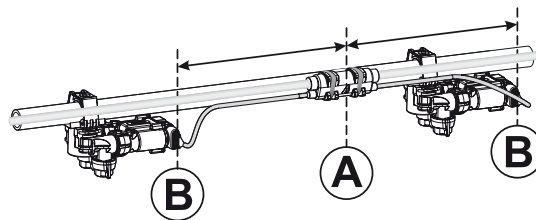


Fig. 22

OK



9 Secure the branches to the boom threading the ties through the suitable recesses.

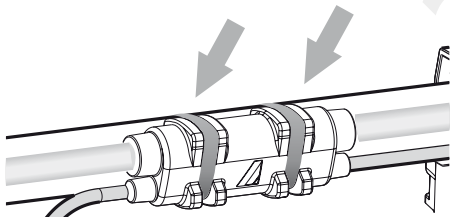


Fig. 23

10 When installing a twin or fourfold nozzle holder, make sure that all connectors are facing the same direction, or the computer might select the wrong nozzle.

OK

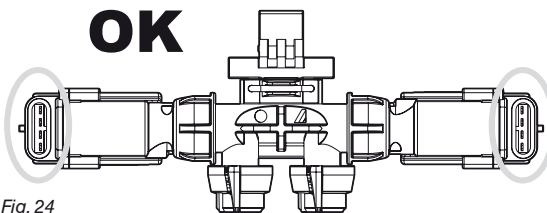
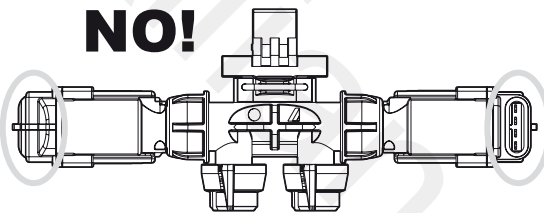
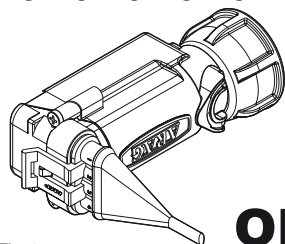


Fig. 24

NO!

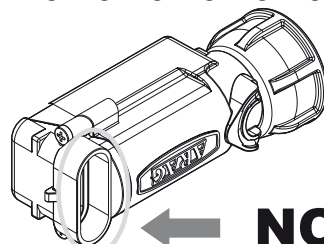


11 Any Seletron connectors left unused must be closed using the suitable plugs (code ECS0075). The plugs must be ordered separately. When the connectors are plugged off, the Seletron is sealed. To avoid damaging the internal components, make sure that when using or cleaning the system the plugs and the connectors are not bare or inserted incorrectly.



OK

Fig. 25



NO!

! WARNING!
DO NOT CONNECT THE SELETRON UNITS.
THE SELETRON ELECTRIC CONNECTORS MUST BE CONNECTED AT A LATER TIME, AFTER SETUP.

! WARNING! TO AVOID DAMAGING ONE OR MORE DEVICES, MAKE SURE THAT NONE OF THE PARTS OF EACH SINGLE SELETRON (BODY, HARNESSSES, ETC.) COME INTO CONTACT WITH MOVING PARTS AT ANY TIME WHEN THE SYSTEM IS IN USE (INSTALLATION, COMMISSIONING, USE AND SHUTDOWN OF THE FARMING MACHINE).

ARAG will not be held responsible for any damage to the system, people, animals or objects caused by failure to follow the guidelines outlined above.

6.5 Hydraulic valves connection

Bravo 400S can control up to 9 hydraulic functions through double-acting valves.

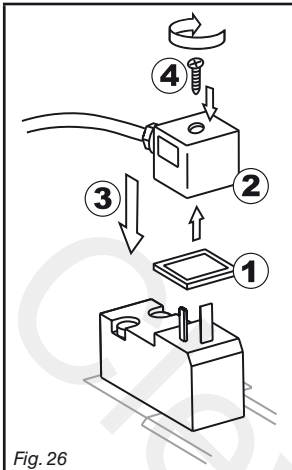


Fig. 26

Fix the connectors to the relevant valves according to the initials indicated in your assembly general diagram (par. 5.1).

- Position seal (1) onto connector (2), then connect the latter pressing it fully home (3); **during this operation, take special care not to bend valve electric contacts.**
- Insert screw inside connector, and screw it (4) until it is tightened.

The function of each switch on the hydraulic function control panel is described below.

- Connect the connector marked with "DD" to the pilot valve, and then the other connectors, as specified on the table:

CONTROL	MOVEMENT	CONNECTOR
Section movement / AUX switch opening 1 - 2 - 3 - 4 - 5 - 6	Opening	1 ÷ 6 A
	Closing	1 ÷ 6 C
Boom height 	Opening	AA
	Closing	AC
Boom locking 	Opening	BA
	Closing	BC
Boom leveling 	Opening	CA
	Closing	CC

6.6 Sensor connection

Fix the connectors to the relevant functions according to the initials indicated in your assembly general diagram (par. 5.1).

Harness cables are marked with a symbol denoting their functions: please see the table for correct harness connection.



Use ARAG sensors: use of unsuitable sensors not provided by ARAG automatically voids the warranty. ARAG is not liable for damage to the equipment, persons or animals caused by failure to observe the above instructions.

ITEM	CONNECTION
F	Flowmeter
L	Level sensor
M	Pressure sensor
S	Speed sensor
T	Filling flowmeter
X	RPM sensor

- The products are supplied with the sensor installation instructions.
The following speed sensors can also be used as RPM sensors:

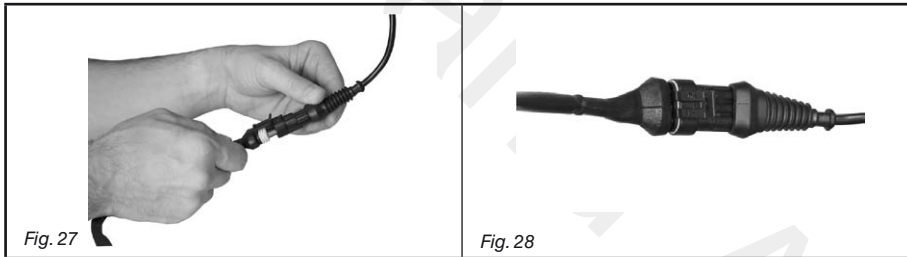
- inductive speed sensor (code 467100.086);
- magnetic speed sensor (code 467100.100).

- Connection of:

- flowmeter;
- pressure sensor;
- level sensor
- filling flowmeter;
- RPM sensor.

All ARAG sensors use the same type of connector.

Connect the sensor connector to the relevant harness; make sure it is correctly fitted and push it until locking it.



6.7 Camera connection

Bravo 400S can be connected to one or two cameras code 46700100 (purchased separately) using the suitable cables listed in the ARAG general catalogue.

Connect the connector to the monitor (see connection points at par. 5.2) and the other cable end to the camera: ensure it is correctly in place and turn the ring nut clockwise until blocking it.

6.8 Power supply connection



WARNING:

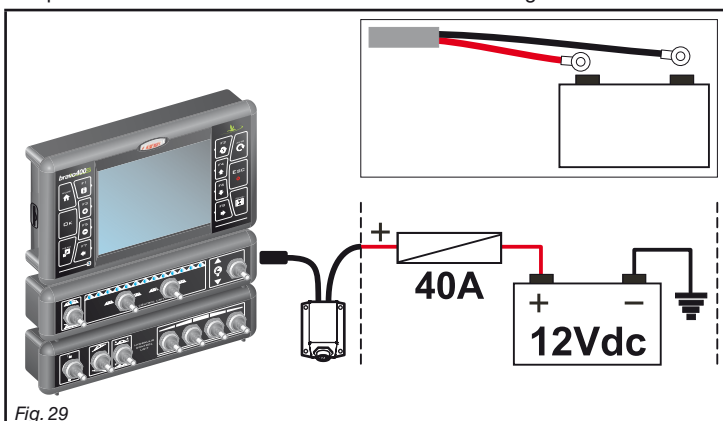
To avoid short circuits, do not connect the power cables to battery before the installation is completed. Before powering up the computer, make sure the tractor battery voltage is as specified (12 Vdc).

BRAVO 400S is supplied directly by the farming machine battery (12 Vdc): ALWAYS switch on the system through the computer, and then remember to switch it off using the specific key on the control panel.



If BRAVO 400S remains on for a long time with the machine off, the tractor battery could run flat: in case of prolonged breaks of the machine with engine off, make sure the computer is off, too.

The power source must be connected as indicated in Fig. 29:



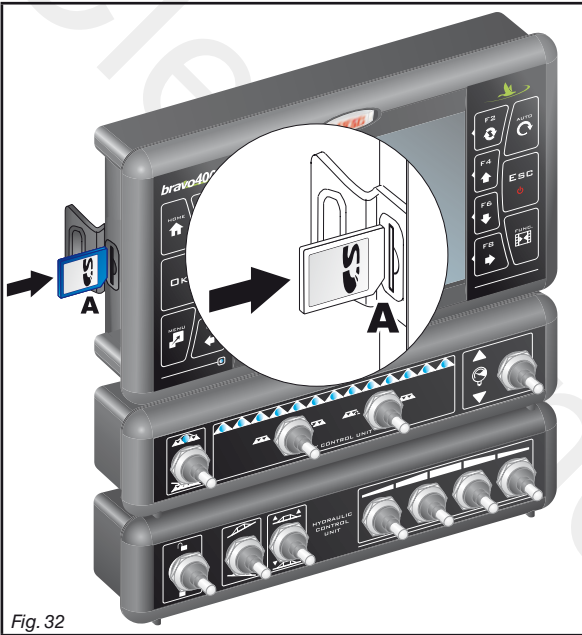
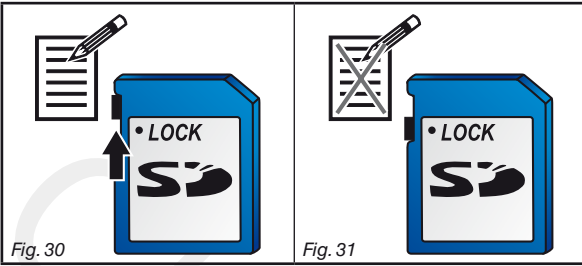
Connect the power cable directly to the battery using the suitable eyelets. WARNING! DO NOT connect to key-operated switch (15/54).

6.9 SD memory card

The SD memory card may be used to exchange data with the BRAVO 400S computer.



**Before using it make sure the card is not protected (Fig. 30).
The system is ONLY compatible with SD or SDHC memory cards.**



• **Insertion**

Insert the memory card making sure to orient it correctly: the card cut edge **A** must be face down; push the card until it engages into place and close the slot with the cover.

• **Removal**

Press and immediately release the card into the slot and slide it out.

6.10 Pen drive

The pen drive may be used to exchange data with the BRAVO 400S computer.



**Before using it make sure the pen drive is not protected.
All pen drives with up to 8 GB memory are compatible.**

7 SETUP

7.1 Setup preparation

Before computer setup, check:

- that all components are correctly installed (control unit and sensors);
- the correct connection to the power source;
- the correct connection of components (control unit and sensors).

Failure to correctly connect system components or to use specified components might damage the device or its components.



WARNING! DO NOT CONNECT THE CONNECTORS TO THE SELETRON NOZZLE HOLDERS. THE SELETRON ELECTRIC CONNECTORS MUST BE CONNECTED AT A LATER TIME, DURING THE PAIRING PROCEDURE (chap. 11 Seletron connection).

7.2 Switching on



Fig. 33

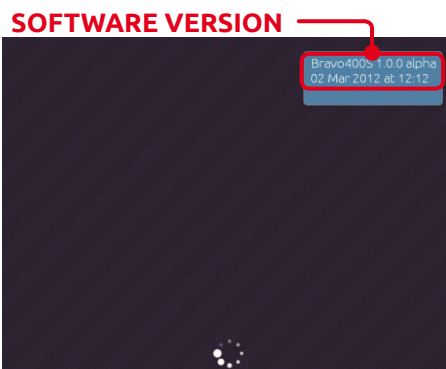


Fig. 34

Keep key pressed until Bravo 400S displays the screen shown in Fig. 33. The software version is shown immediately afterwards (Fig. 34).

FIRST DEVICE SWITCHING ON



Fig. 35

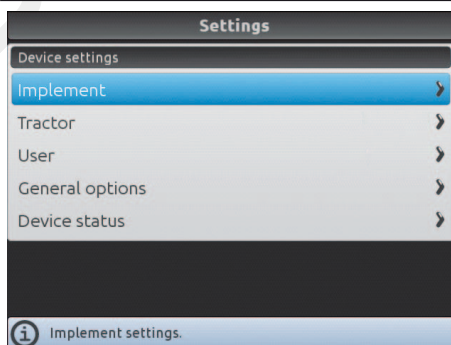


Fig. 36

Upon first switching on, after the software version, Bravo 400S displays the "Home" screen (Fig. 35): press **FB** and enter the device basic settings (chap. 9).

ORDINARY SWITCHING ON



Fig. 37

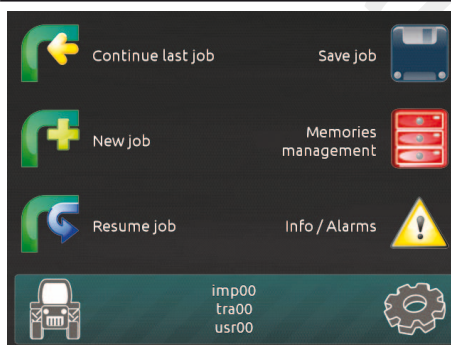
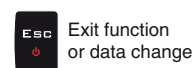
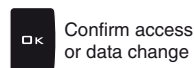


Fig. 38

After the software version, Bravo 400S displays the Select User prompt (Fig. 37). Press **F4** or **F6** to move across the available items, then press **OK** to confirm your selection. At this point, Bravo 400S displays the "Home" screen (Fig. 38).



Value Increase / decrease



7.3 Switching off

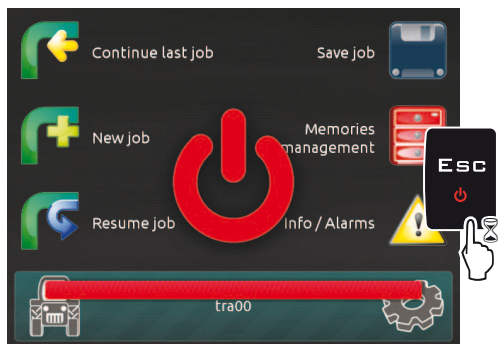


Fig. 39

Keep **ESC** key pressed until Bravo 400S is switched off.



During switching off Bravo 400S saves the current job, do NOT press any other key and do NOT disconnect the power supply until Bravo 400S display turns off.

WARNING: ALWAYS use the special key to switch off the device; otherwise ALL data concerning the spraying and the setup will be lost.

7.4 Use of keys for setup

SELECTION AND ACCESS TO MENU ITEMS

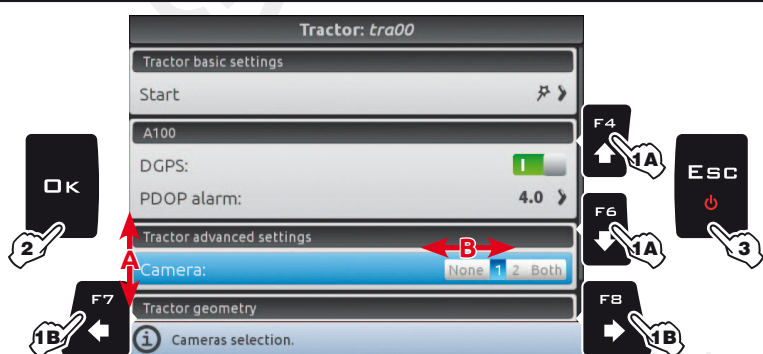


Fig. 40

1A Press in succession to move across the menu items (UP / DOWN). The selected item is highlighted with a blue bar (**A**).

1B Press in succession to move across the available options (LEFT / RIGHT).

Display options (**B**):

None **1** **2** The selected item is highlighted with a blue bar.

Active option
 Inactive option

2 Press to access the selected item or to confirm modification.

3 Press to exit screen without confirming modification.

ENTERING A NUMERICAL VALUE

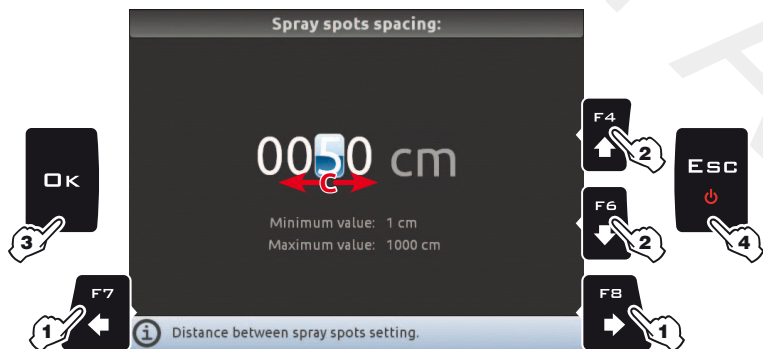


Fig. 41

1 Press to move the cursor (**C**) across the digits

2 Press to edit the highlighted digit (increase, decrease)

3 Press to confirm.

4 Press to exit screen without confirming modification.

ENTERING TEXT



Fig. 42

1A Press in succession to select the character you wish to type (UP / DOWN).

1B Press in succession to select the character you wish to type (RIGHT / LEFT).

2 Press to confirm the selected character.

3 Press to delete the character before the cursor.

4 Press to save the name.

5 Press to exit screen without confirming modification.

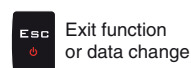
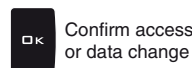
Legend:

imp03 |

	Typed Name			Selected character
	Cursor			Caps lock
	Shift cursor across name characters			

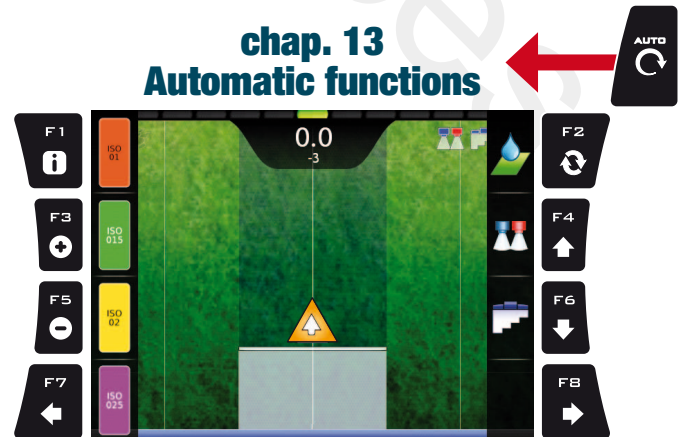
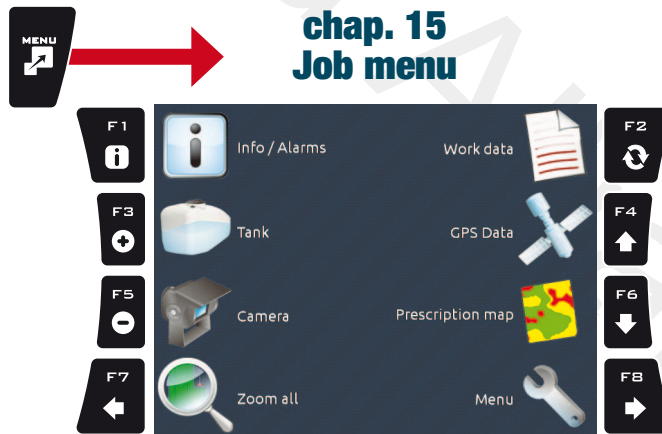
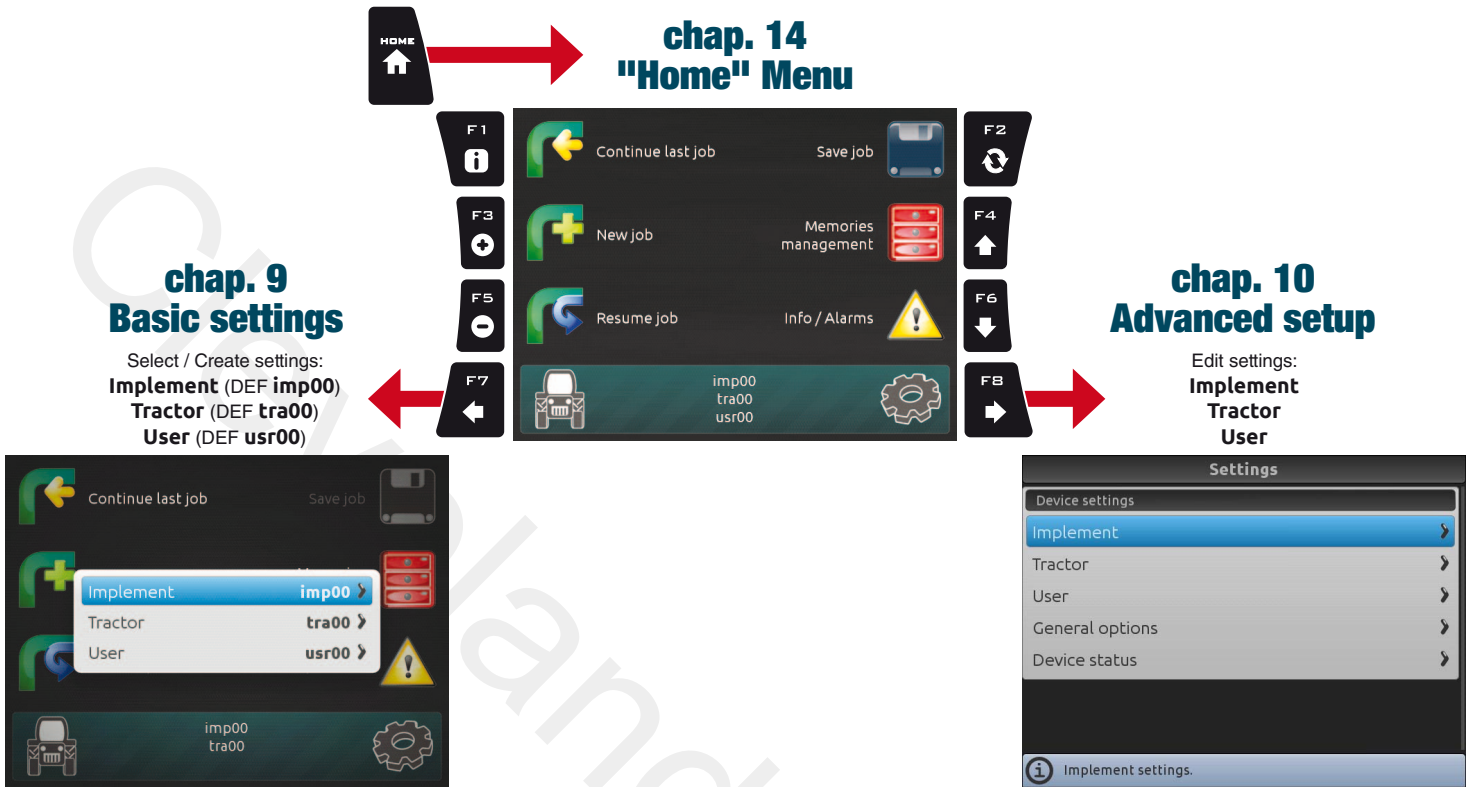


Value Increase / decrease



8 MENU STRUCTURE

Upon first switching on, press **F8** and enter the device basic settings (chap. 9). Afterwards, it will be possible to select the preset settings by pressing **F7**.



9 BASIC SETTINGS

GUIDED SETUP PROCEDURE UPON FIRST SWITCHING ON

1 LANGUAGE SETTING

- In the "Home" screen (Fig. 43) press **FB** to enter the **Settings** menu (Fig. 44).
- Select **General options > Language** and set the language of Bravo 400S.
- Press **ESC** and return to the **Settings** menu. Now select **Implement** to start guided setup procedure as shown in Fig. 45.

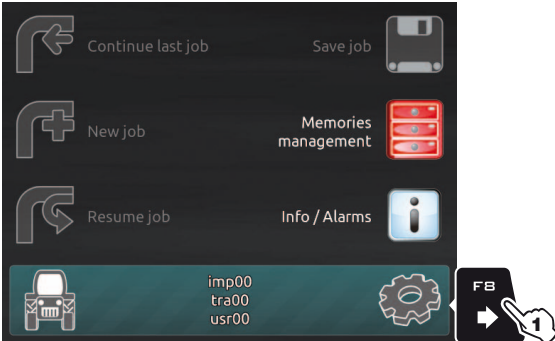


Fig. 43

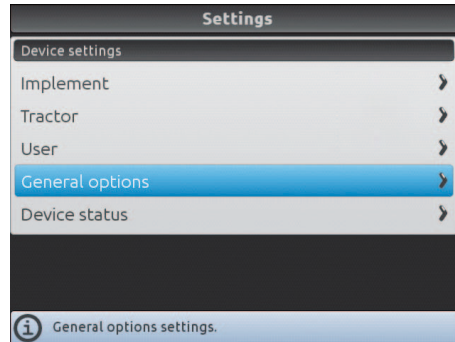


Fig. 44

For a correct use of the keys during setting, refer to par. 7.4.

2 ATTREZZO

- Upon first switching on, Bravo 400S starts the guided setup procedure for the **Implement**: go through each step selecting the desired options (example in Fig. 46).
- **OK**: next step **ESC**: previous step.
- When the message in Fig. 47 appears, the implement setup is complete. Press **OK**.
- Press **ESC** and return to the **Settings** menu. Now select **Tractor** to start guided setup procedure as shown in Fig. 48.

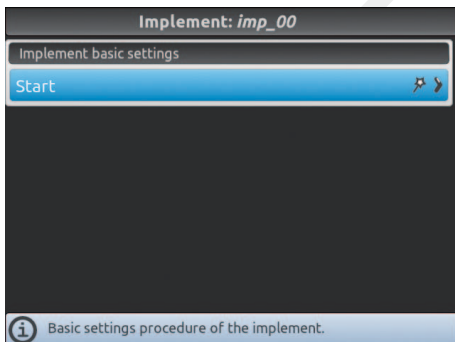


Fig. 45



Fig. 46

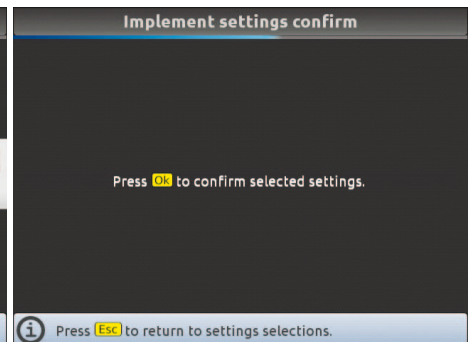


Fig. 47

BASIC IMPLEMENT SETTINGS

• IMPLEMENT TYPE

Sprayer (Seletron): system with Seletron valves.

GPS guidance monitor: Bravo 400S is only used as a driving aid and does not control spraying (it is not connected to the RCU).

• IMPLEMENT CONNECTION TYPE

3-point hitch: 3-point / self-propelled machine

Towing hitch: towed machine

• MAIN VALVE

Main control valve installed on the control unit:

None

2 ways (drain valve)

3 ways (main valve)

• SPRAYING SPOT TYPE

Seletron type: single, twin or fourfold

• FLOWRATE REFERENCE SENSOR

Device used to calculate flowrate:

Flowmeter

Pressure: measured pressure is used to calculate application rate.

Both: within the working limits the computer uses the flowmeter, otherwise it uses the pressure sensor, ONLY if properly configured.

CONTINUES >>>

Enter selected character	Delete selected character	Scroll (LEFT / RIGHT)	Scroll (UP / DOWN)	Value Increase / decrease	Confirm access or data change	Exit function or data change	Par. 7.4
--------------------------	---------------------------	-----------------------	--------------------	---------------------------	-------------------------------	------------------------------	----------

3 TRACTOR

- Upon first switching on, Bravo 400S starts the guided setup procedure for the **Tractor**: go through each step selecting the desired options (example in Fig. 49).
- When the message in Fig. 50 appears, the tractor configuration is complete. Press **OK**.
- Press **ESC** and return to the **Settings** menu.

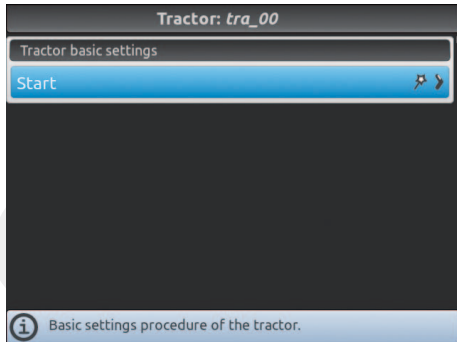


Fig. 48

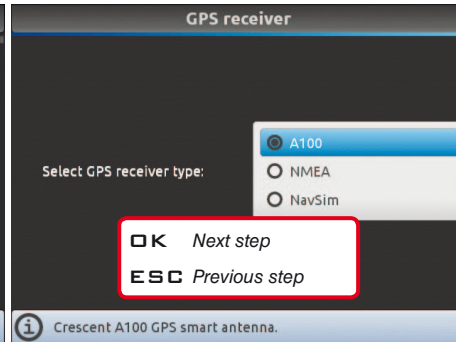


Fig. 49

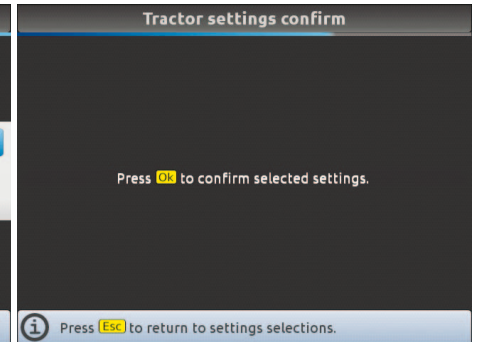


Fig. 50

BASIC TRACTOR SETTINGS

- **A100**: ARAG receiver code 520100.693.
- **NMEA**: all GPS receivers with NMEA183 protocol and with the following features:
 - 10 Hz GGA message; latitude and longitude coordinates with at least 6 decimal digits.
 - 10 Hz VTG message.
 - 0.1 Hz ZTA message.
 - Serial port 57600 bps, n, 8, 1.
- **NavSim**: available ONLY for ARAG personnel for system diagnostics.

4 Basic setup procedure is now complete (*). Now it is possible to start the advanced setup procedure, described in chap. 10.

(*) This can be started again at any time, by selecting **Start** in the **Implement** and **Tractor** menu.

F1 Enter selected character	F2 Delete selected character	F7 F8 Scroll (LEFT / RIGHT)	F4 F6 Scroll (UP / DOWN) Value Increase / decrease	OK Confirm access or data change	ESC Exit function or data change	Par. 74
-----------------------------	------------------------------	-----------------------------	--	----------------------------------	----------------------------------	---------

10 ADVANCED SETUP

ACTIVE SETTINGS



Fig. 51

Before carrying out the advanced setup procedure, select the type of Implement, Tractor and User you wish to use: all modifications made to the advanced setup will be applied to the ACTIVE SETTINGS (in the example here imp00, tra00, usr00).

IMPLEMENT, TRACTOR AND USER TYPE SELECTION

- 1 Press **F7** in the "Home" screen (Fig. 52).
- 2 In the screen shown in Fig. 53 select the **Implement (Tractor or User)** and press **OK**.
Now it's possible to create a new setup (**3a** or **3b**), or select an existing one (**3c**):
in both cases the setup will be enabled and the name will be displayed in the "Home" screen (Fig. 51).

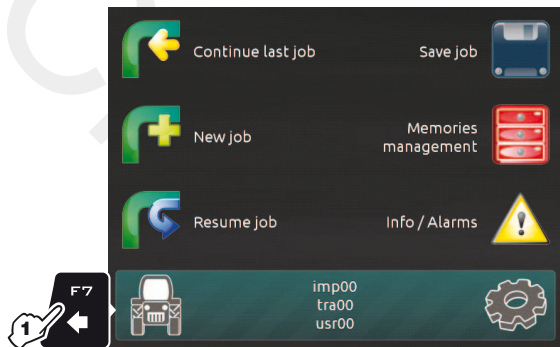


Fig. 52

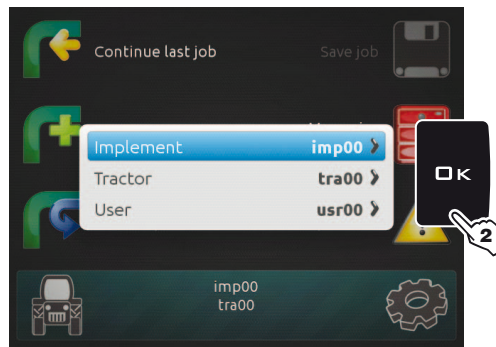


Fig. 53

3a NEW SETUP CREATION:

Select **New Implement (a)** in Fig. 54 to create a new setup and press **OK**.
Type the name (in the example of Fig. 55: **imp01**) and press **OK**.
The new setup is now active on the computer (Fig. 56). Before moving on to the advanced setup procedure repeat the basic setup (chap. 9).
You can follow the same procedure for **Tractor (b)** and **User (c)** setup.



Fig. 54

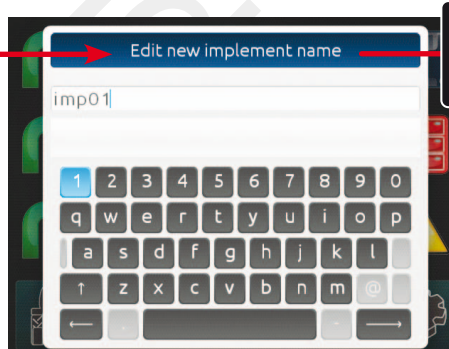


Fig. 55

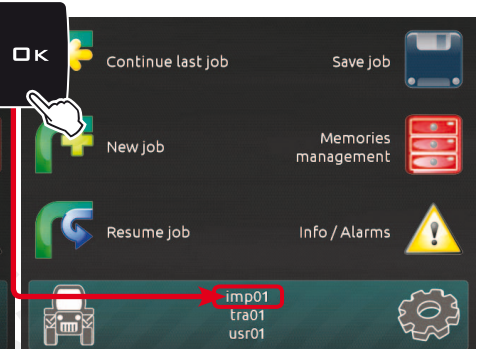


Fig. 56

3b NEW SETUP CREATION (BY COPYING DATA FROM AN EXISTING SETUP):

Select **Copy implement (d)** in Fig. 57 to copy the active setup and save the data on a new one; press **OK**.
Type the name (in the example of Fig. 58: **imp01**) and press **OK**.
The saved setup is now active on the computer (Fig. 59). Proceed to advanced setup.
You can follow the same procedure for **Tractor (e)** and **User (f)** setup.



Fig. 57

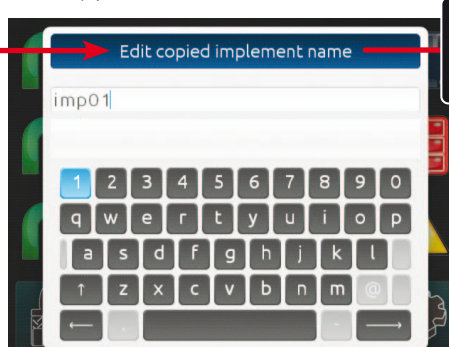


Fig. 58

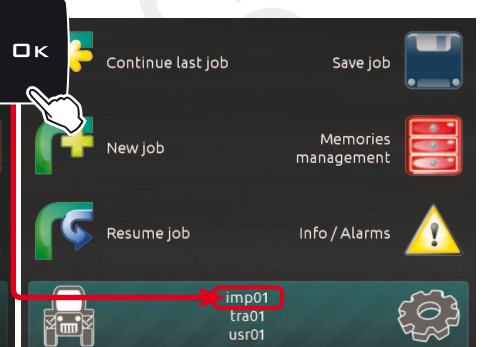


Fig. 59

CONTINUES

3c SETUP SELECTION:

Instead of saving, you can select a previously saved setup.
 Select the setup from the names on the list (g in the example of Fig. 60: **imp00**) and press **OK**.
 The selected setup is now active on the computer (Fig. 61). Proceed to advanced setup.
 You can follow the same procedure for **Tractor (h)** and **User (i)** setup.



Fig. 60

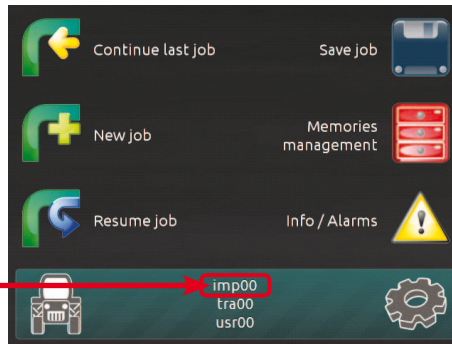


Fig. 61

 Now you can start the advanced setup procedure: all modifications will be applied to the ACTIVE SETUP (in the example below **imp00, tra00, usr00**).

ADVANCED SETUP



Fig. 62

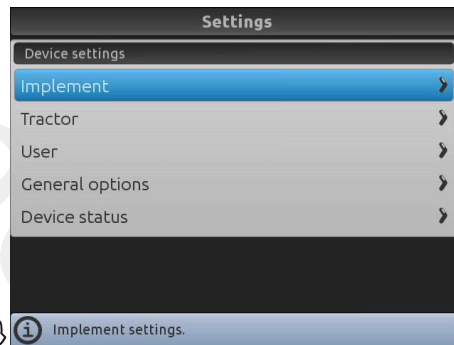


Fig. 63

- In the "Home" screen (Fig. 62) press **FB** to enter the Settings menu (Fig. 63).

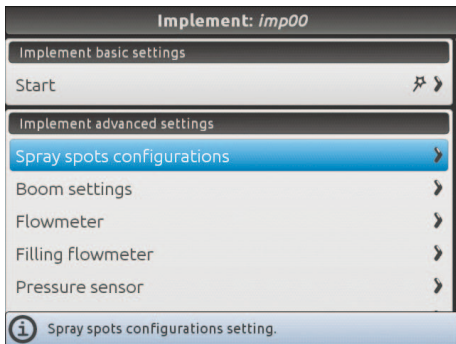











Fig. 64

- Start guided setup procedure for Bravo 400S: select the desired menu item (with **F4** or **F6**) and press **OK** to enter settings for the selected item.

 **THE BASIC SETTINGS (Chap. 9), AFFECT WHICH MENU ITEMS ARE DISPLAYED IN Fig. 64 AND WHICH ADVANCED SETTINGS IT IS POSSIBLE TO CONTROL.**

Below is a summary of key functions during setup.
 For the full description, see par. 7.4.

 Enter selected character	 Delete selected character	  Scroll (LEFT / RIGHT)	  Scroll (UP / DOWN) Value Increase / decrease	 Confirm access or data change	 Exit function or data change	 Par. 7.4
---	---	---	--	--	--	--

The type of implement displayed depends on the selected basic settings (chap. 9), affecting which items are displayed in Fig. 65.

10.1 Implement - SPRAYER (SELETRON)

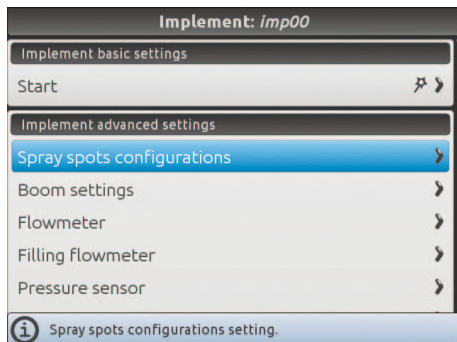


Fig. 65

Implement advanced settings

- **Spray spots configurations** (par. 10.1.1).
- **Boom settings** (par. 10.1.2).
- **Flowmeter** (par. 10.1.3).
- **Filling flowmeter** (par. 10.1.4).
- **Pressure sensor** (par. 10.1.5).
- **Valves** (par. 10.1.6).
- **Nozzles data** (par. 10.1.7).
- **Wheel sensor** (par. 10.1.8).
- **Rev counter** (par. 10.1.9).
- **Tank** (par. 10.1.10).
- **Alarms** (par. 10.1.11).
- **Working parameters** (par. 10.1.12).
- **Device calibration** (par. 10.1.13).

Implement geometry

- **3-point implement geometry settings** (par. 10.1.14).
- **Towed implement geometry settings** (par. 10.1.15).

10.1.1 Spray spots configurations

Allows setting 20 different configurations (i.e., 20 nozzle combinations), which can be selected before starting each job. Each configuration indicates which type of nozzle is installed on the boom's spraying points.

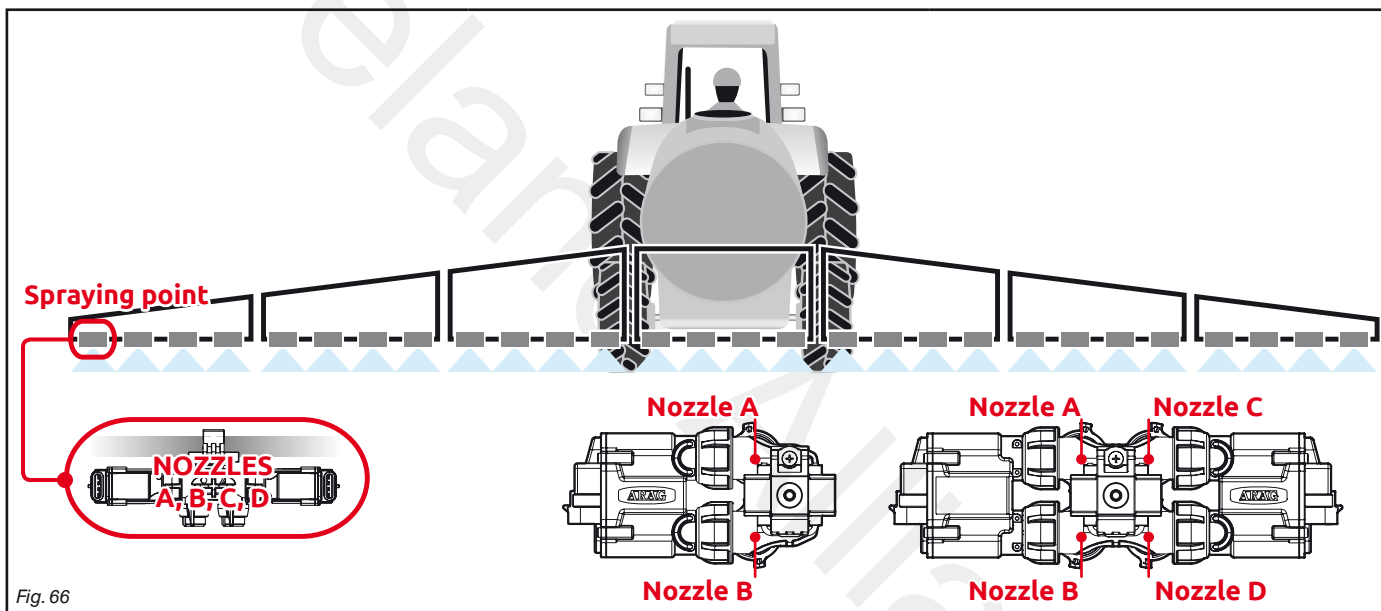


Fig. 66

During guided setup (chap. 9), the computer will ask you to indicate which type of Seletron is installed at said spraying points (single, twin or fourfold). Depending on the selected option the number of nozzles to be programmed in this menu will vary.

- Select the configuration you wish to set up (Fig. 67).
- Select the nozzle you wish to set up (A, B, C or D, in Fig. 68).
- Select one of the suggested nozzles (Fig. 69): if a nozzle is NOT in use, disable it by selecting .
- Repeat the setup for each configuration.

The nozzle settings are the same for all spraying points on the boom.

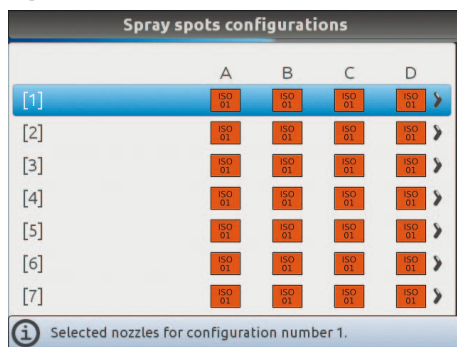


Fig. 67

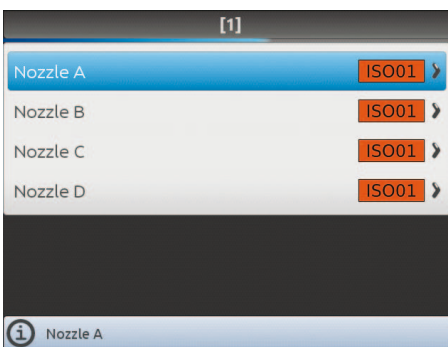


Fig. 68

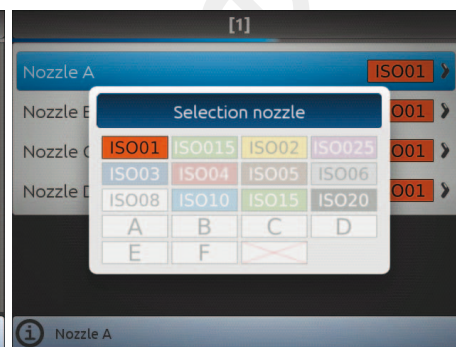


Fig. 69

10.1.2 Boom settings

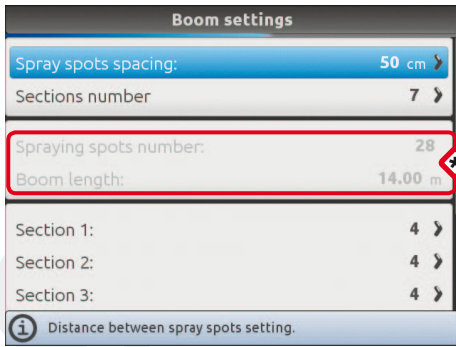


Fig. 70

⚠ Depending on the selected settings, the number of spraying points as well as the value of the boom width, displayed in Fig. 70, will change.

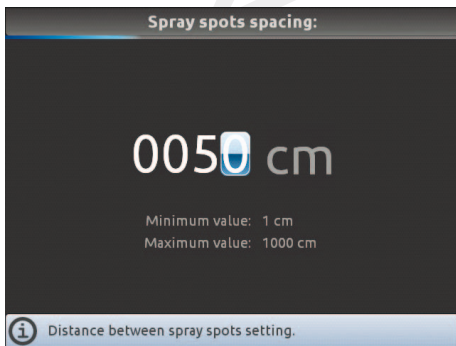


Fig. 72

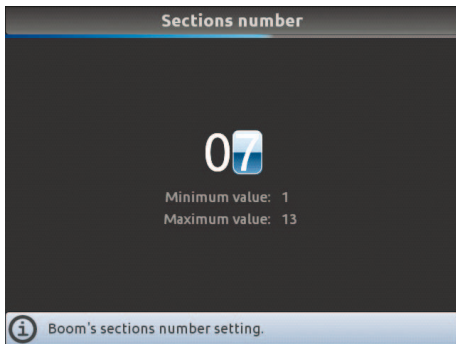


Fig. 73

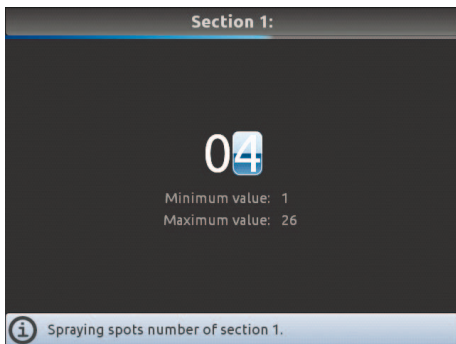


Fig. 74

Spray spots spacing



The operator may choose the way in which the boom is subdivided into different sections: this is done in order to act on the corresponding switch when closing sections manually. With automatic management, instead, the computer acts on each single Seletron separately.

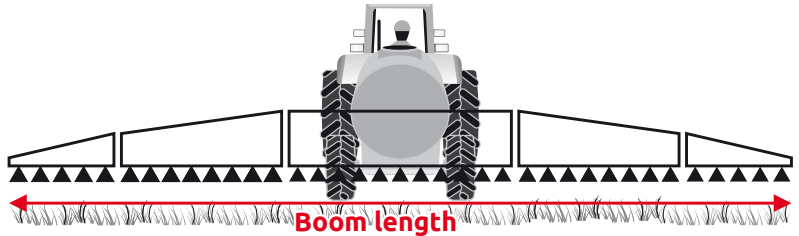


Fig. 71

• Spray spots spacing

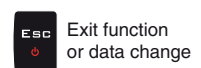
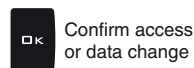
Indicate the distance between spraying points (nozzle holders).

• Sections number

Indicate the total number of boom sections.

• Section 1 ÷ 13

- Indicate the number of spraying points (nozzle holders) installed on each boom section.
- Repeat the setup for each section (Fig. 70).



10.1.3 Flowmeter

Enter the values for the flowmeter installed on the system.
The table below indicates the values that are automatically set when selecting the flowmeter code.
If the installed flowmeter is not displayed, select **Other** and enter the relevant values.

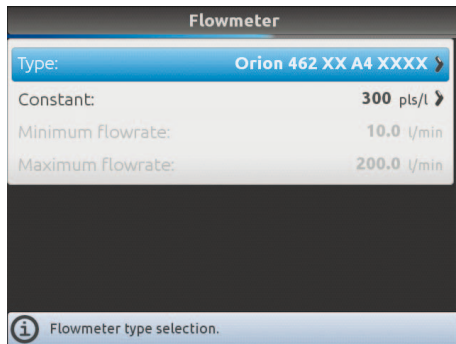


Fig. 75

ORION FLOWMETERS						
Type	Constant		Minimum flowrate		Maximum flowrate	
	pls/l	pls/gal	l/min	GPM	l/min	GPM
4621xA0xxxx	6000	22710	0.5	0.10	10	2.6
4621xA1xxxx	3000	11355	1	0.30	20	5.3
4621xA2xxxx	1200	4542	2.5	0.70	50	13.2
4621xA3xxxx	600	2271	5	1.30	100	26.4
462xxA4xxxx	300	1135	10	2.60	200	52.8
4622xA5xxxx	150	568	20	5.30	400	105.7
4622xA6xxxx	100	378	30	7.90	600	158.5
Other	625	2366	10	2.60	200	52.8

WOLF FLOWMETERS						
Type	Constant		Minimum flowrate		Maximum flowrate	
	pls/l	pls/gal	l/min	GPM	l/min	GPM
462x 2xxx	1025	3880	2.5	0.7	50	13.2
462x3xxx	625	2366	5.0	1.3	100	26.4
462x4xxx	250	946	10.0	2.6	200	52.8
462x5xxx	132	500	20.0	5.3	400	105.7
462x7xxx	60	227	40.0	10.6	800	211.3

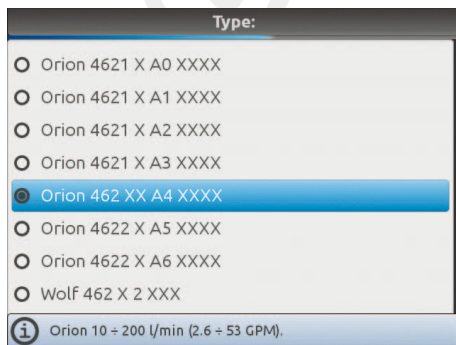


Fig. 76

• Type

Indicate the type of flowmeter installed.

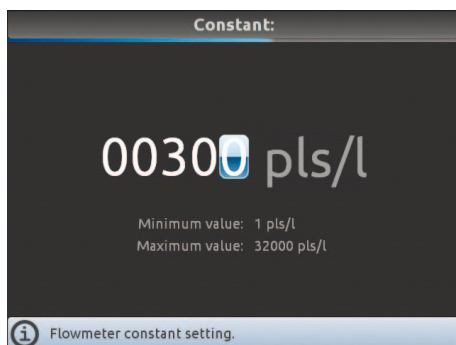


Fig. 77

• Constant

Indicate the constant of the installed flowmeter.

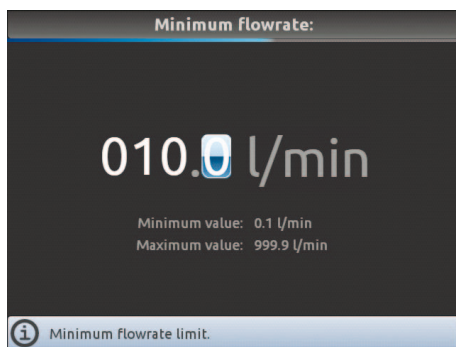


Fig. 78

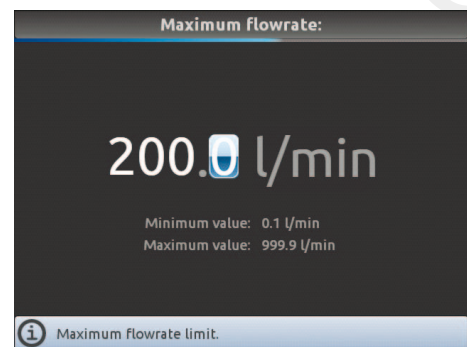


Fig. 79

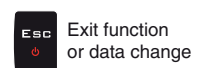
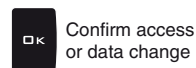
• Minimum flowrate
• Maximum flowrate



The items **Minimum flowrate** and **Maximum flowrate** can be modified only when the option **Other** (**Type** menu in Fig. 76) is enabled.

Enable the relevant function on the **Alarms** menu (par. 10.1.11) if you want the computer to trigger an alarm when, during spraying, the flowmeter rate is outside the set range.

For the procedure to be followed when an alarm occurs, please refer to par. 17.1 Error messages.



10.1.4 Filling flowmeter

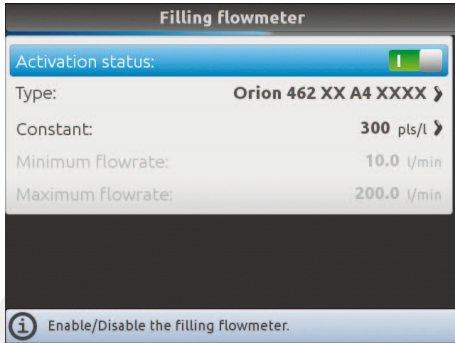


Fig. 80

• Activation status

To configure the items on this menu, you must enable the filling flowmeter (Flowmeter enabled / Flowmeter disabled).

Enter the values for the filling flowmeter installed on the system: the following table indicates the values which will be set automatically by selecting the corresponding flowmeter code. If the installed filling flowmeter is not displayed, select **Other** and enter the relevant values.

ORION FLOWMETERS							WOLF FLOWMETERS						
Type	Constant		Minimum flowrate		Maximum flowrate		Type	Constant		Minimum flowrate		Maximum flowrate	
	pls/l	pls/gal	l/min	GPM	l/min	GPM		pls/l	pls/gal	l/min	GPM	l/min	GPM
462XA4XXXX	300	1135	10	2.60	200	52.8	462x4xxx	250	946	10.0	2.6	200	52.8
4622XA5XXXX	150	568	20	5.30	400	105.7	462x5xxx	132	500	20.0	5.3	400	105.7
4622XA6XXXX	100	378	30	7.90	600	158.5	462x7xxx	60	227	40.0	10.6	800	211.3
Other	625	2366	10	2.60	200	52.8							

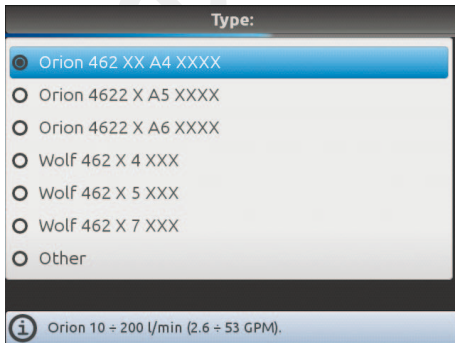


Fig. 81

• Type

Indicate the type of flowmeter installed.

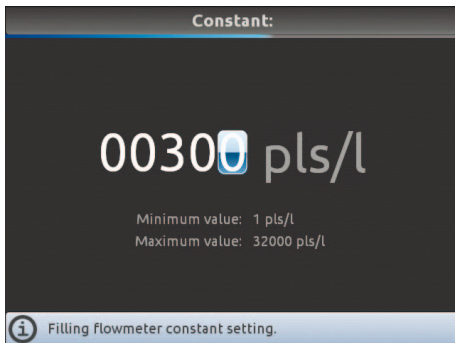


Fig. 82

• Constant

Indicate the constant of the installed filling flowmeter.

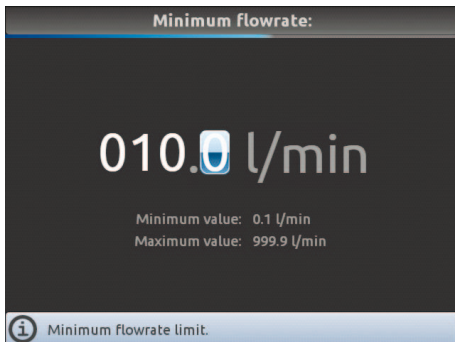


Fig. 83

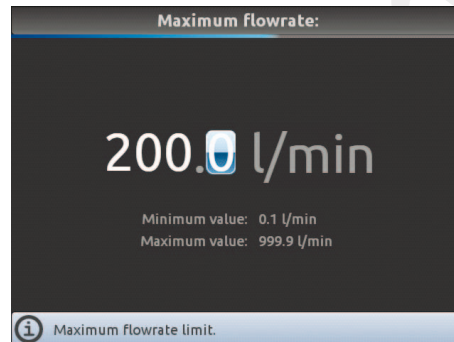


Fig. 84

• Minimum flowrate
• Maximum flowrate

The items **Minimum flowrate** and **Maximum flowrate** can be modified only when the option **Other** (Fig. 81) is enabled.

Indicate the minimum and maximum pressure for the filling flowmeter installed on the system.

10.1.5 Pressure sensor

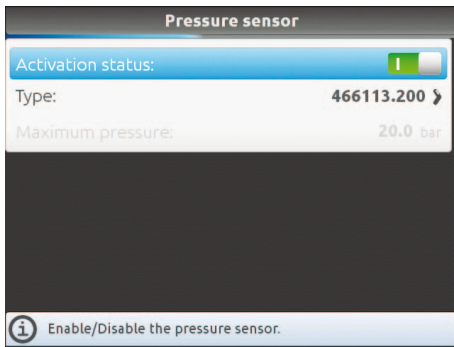


Fig. 85

• Activation status

To configure the items on this menu, you must enable the pressure sensor (Sensor enabled / Sensor enabled - cannot be modified / Sensor disabled).

- Enter the values for the pressure sensor installed on the system.

The table below indicates the values that are automatically set selecting the sensor code. If the installed sensor is not displayed, select **Other** and enter the relevant values.

ARAG PRESSURE SENSOR

Type	Maximum pressure	
	bar	PSI
ARAG 466113.200	20.0	290
ARAG 466113.500	50.0	725
Other	50.0	725

Depending on the basic settings (**Delivery cal. sensor**, chap. 9), the pressure sensor, once properly set up, can perform different functions:

- **Pressure sensor:** the pressure measured by the sensor is used to calculate the spray rate.
- **Flowmeter:** the pressure sensor displays ONLY the job pressure.
- **Both:** the pressure sensor displays the job pressure when the machine works within the flowmeter limits.

When the flowmeter operates outside the limits the pressure measured by the sensor is used to calculate the spray rate.

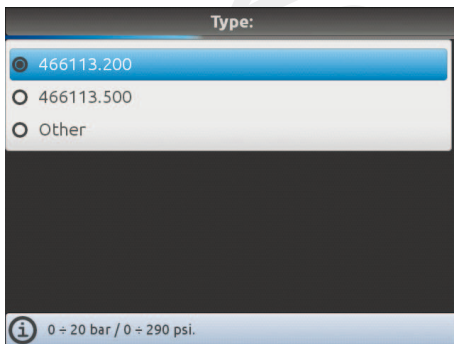


Fig. 86

• Type

Indicate the type of pressure sensor installed.



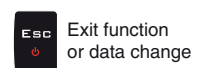
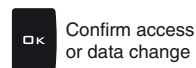
Fig. 87

• Maximum pressure



The item **Maximum pressure** can be modified only when the option **Other** is enabled.

Indicate the full scale of the pressure sensor installed on the system.



10.1.6 Valves

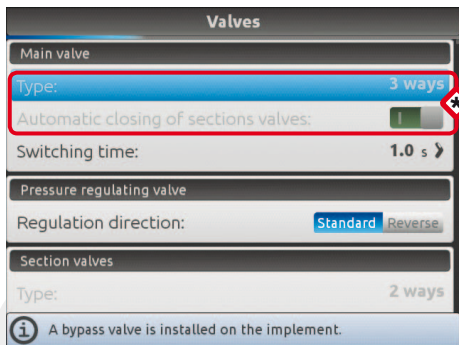


Fig. 88

Set the type of valve installed on the system and the relevant values.

⚠ The items **Main valve > Type** and **Automatic closing of sections valves** appear as a REMINDER: they are enabled during guided setup (chap. 9). Therefore, they cannot be modified from this screen.

MAIN VALVE

• Type (REMINDER)

Main control valve installed. Available options are: **None**, **2 ways** (drain valve), **3 ways** (main valve)

• Automatic closing of sections valves (REMINDER)

On a Seletron system, automatic closing of sections is automatically enabled ("M" type):

The section valves are closed or opened by acting on the main switch, provided that the section valve specific switch is in the correct position, i.e. if the section switches are set to OFF (lever down), acting on the main switch the sections will not be controlled. If one or more section valve switches are set to ON (lever up), opening or closing the main switch opens or closes the section valves as well.

• Switching time

Indicate the time between the moment when the command is sent to the main valve and the actual moment in which spraying starts / stops.

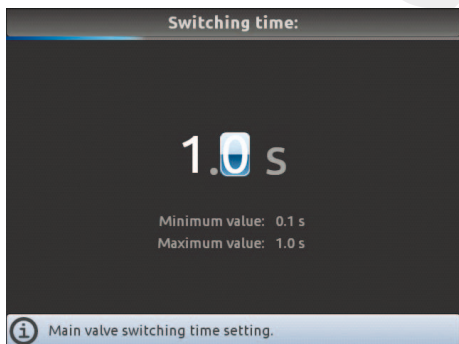
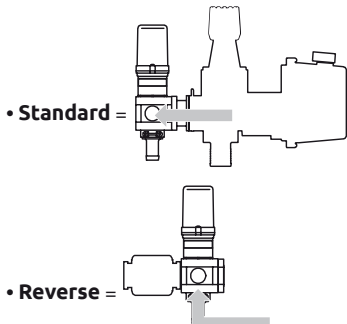


Fig. 89

PRESSURE REGULATING VALVE

• Regulation direction

Indicate the type of installed control valve. Available options are:



CONTINUES >>>

Enter selected character	Delete selected character	Scroll (LEFT / RIGHT)	Scroll (UP / DOWN)	Value Increase / decrease	Confirm access or data change	Exit function or data change	Par. 7.4
--------------------------	---------------------------	-----------------------	--------------------	---------------------------	-------------------------------	------------------------------	----------

SECTION VALVES

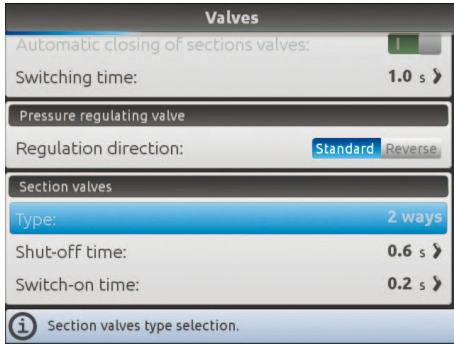


Fig. 90

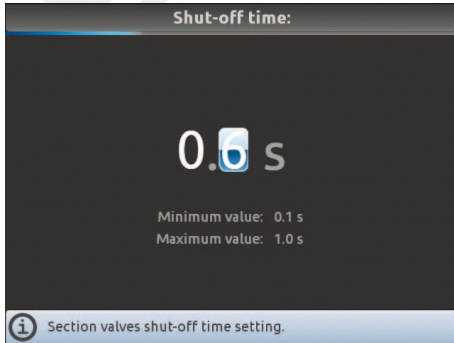


Fig. 91

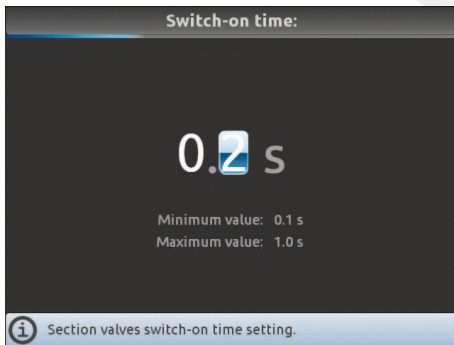


Fig. 92

• Type (REMINDER)

On a Seletron system, section valves are of the **2 ways** type (without calibrated backflows) and are automatically set.

• Shut-off time

Indicate the time between the moment when the command is sent to the Seletron valves and the actual moment in which product output stops.

• Switch-on time

Indicate the time between the moment when the command is sent to the Seletron valves and the actual moment in which product output starts.

10.1.7 Nozzles data

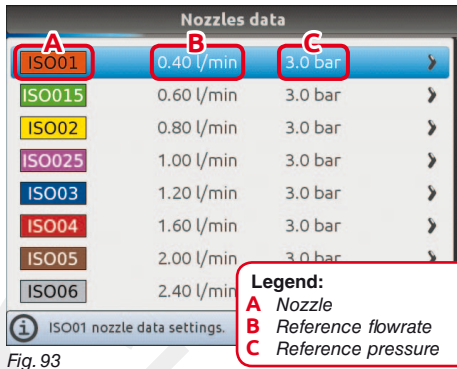


Fig. 93

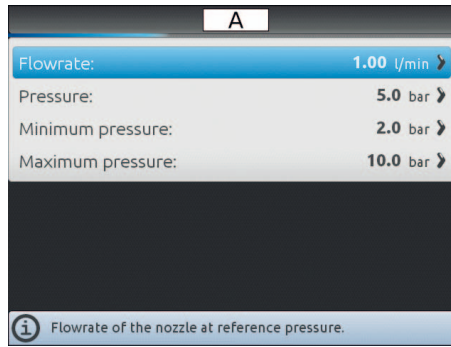


Fig. 94

Allows setting the values of 12 types of ISO nozzles and 6 "User" nozzles (A, B, C, D, E, F).

The values for Flowrate and Pressure can be modified for "User" nozzles ONLY, not for ISO nozzles.

- Select the nozzle you wish to set up (Fig. 93).
- Enter the relevant features (Fig. 94).
- If necessary, repeat the setup for each nozzle.

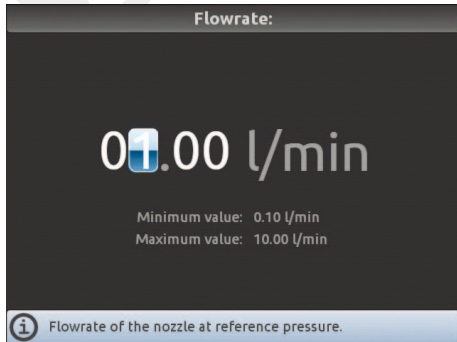


Fig. 95

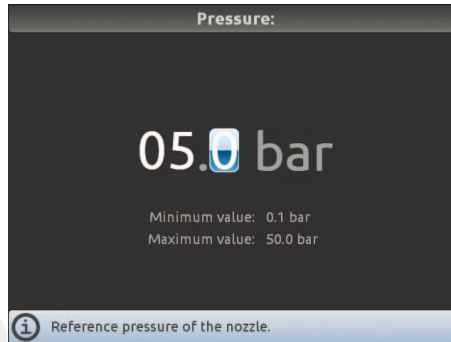


Fig. 96

- Flowrate
- Pressure

Set the reference flowrate and pressure for the selected nozzle.

The rate of the nozzle being used allows Bravo 400S to calculate the pressure without a pressure sensor.

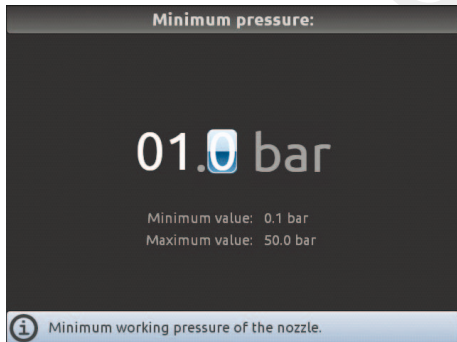


Fig. 97

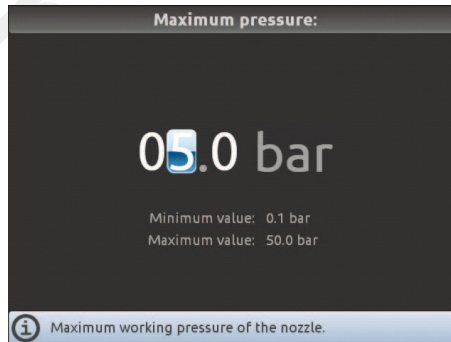


Fig. 98

- Minimum pressure
- Maximum pressure

Set the pressure limits for the selected nozzle. Enable the relevant function on the **Alarms** menu (par. 10.1.11) if you want the computer to trigger an alarm when the nozzle is outside the set range.

For the procedure to be followed when an alarm occurs, please refer to par. 17.1 Error messages.

Pressure limits for the nozzle in use allow Bravo 400S to select the suitable nozzle during spraying, therefore they must be set correctly.

10.1.8 Wheel sensor

Information concerning speed is usually received by the GPS, which is connected directly to Bravo 400S. If there is no GPS signal this menu allows to use the wheel sensor as a source of speed data instead of the GPS, and therefore to calculate the data on the basis of the pulses received by the speed sensor installed on the wheel.

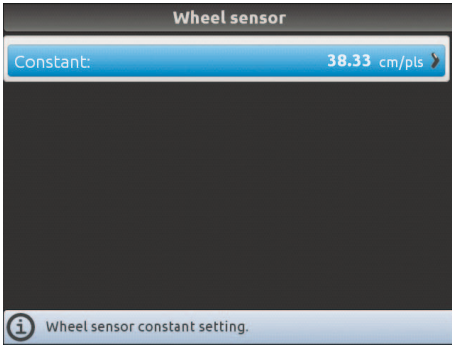


Fig. 99

• Constant

Allows to enter the wheel constant value calculated with the suitable formula. The wheel constant can be calculated with a good approximation by detecting the distance traveled by the wheel with the speed sensor. The longer the distance traveled, the more accurate the wheel constant calculation.

$$K_{wheel} = \frac{\text{distance traveled (cm)}}{\text{no. of detection points} \times \text{wheel rpm}}$$

<distance traveled> distance expressed in cm covered by the wheel along measurement travel.
 <no. of measurement points> number of measurement points (e.g., magnets, bolts, etc.), mounted on wheel.
 <no. of wheel revolutions> number of wheel revolutions required to travel measurement distance.



Take measurements with tyres at the operating pressure.

This test must be performed on medium-hard terrain; for application to very soft or very hard terrain, rolling diameter may vary, leading to inaccurate output calculation; when this is the case, repeat the procedure.

During the test, cover the distance with the tank filled up to half capacity with water.

10.1.9 Rev counter

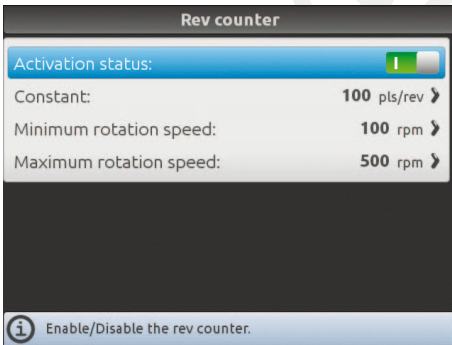


Fig. 100

• Activation status

To configure the items on this menu, you must enable the rev counter (Rev counter enabled / Rev counter disabled).

Enter the values for the rev counter installed on the system.

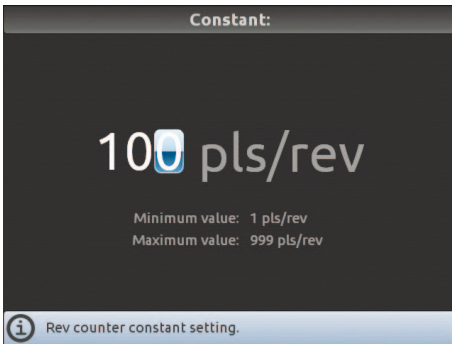


Fig. 101

• Constant

Indicate the constant of the installed rev counter.

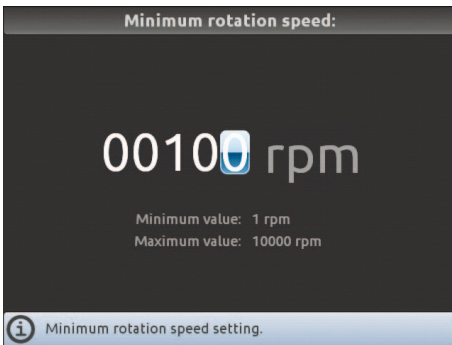


Fig. 102

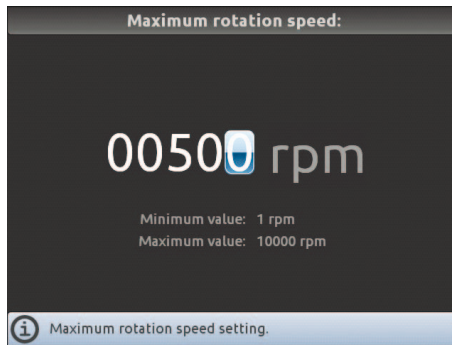


Fig. 103

• Minimum rotation speed
 • Maximum rotation speed

Enable the relevant function on the **Alarms** menu (par. 10.1.11) if you want the computer to trigger an alarm when, during spraying, the measured RPM is outside the set range. For minimum speed, the control is active only when the spraying is active (main switch ON). **For the procedure to be followed when an alarm occurs, please refer to par. 17.1 Error messages.**

10.1.10 Tank

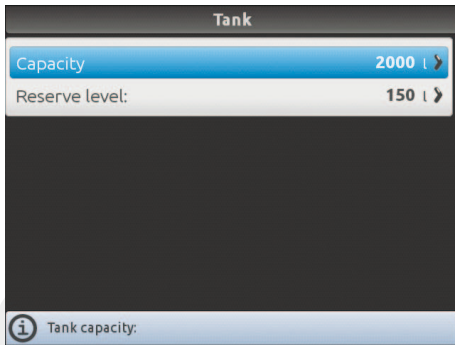


Fig. 104

Set tank capacity and range value.

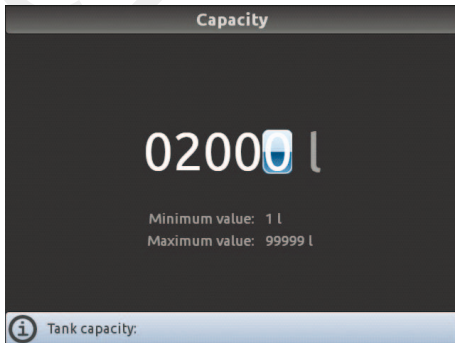


Fig. 105

• Capacity

Indicate tank capacity.

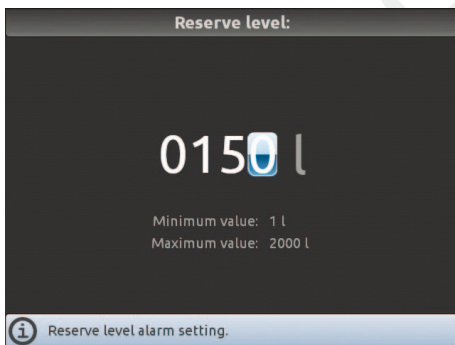


Fig. 106

• Reserve level

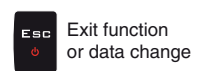
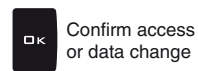
Indicate range value.

The tank alarm is triggered when, during spraying, the tank level falls below the set value.

For the procedure to be followed when an alarm occurs, please refer to par. 17.1 Error messages.



Value Increase / decrease



10.1.11 Alarms

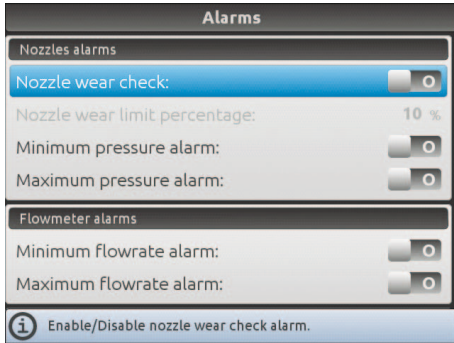


Fig. 107

Set Bravo 400S job alarms.

For the procedure to be followed when an alarm occurs, please refer to par. 17.1 Error messages.

NOZZLES ALARMS

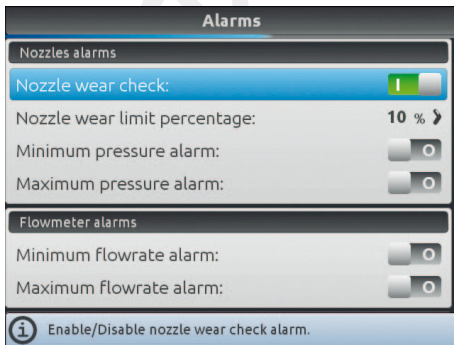


Fig. 108

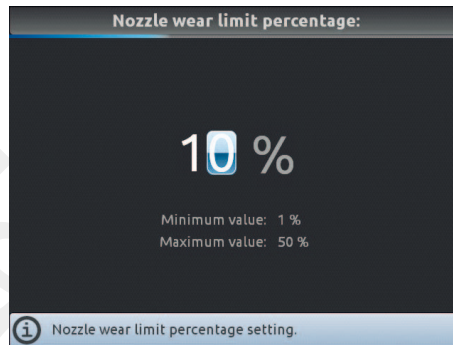


Fig. 109

• Nozzle wear check

To configure the items on this menu, you must enable the nozzle wear check:

- Check enabled
- Check disabled

This alarm can be enabled **ONLY** if the system features both flowmeter and pressure sensor.

• Nozzle wear limit percentage

Set the acceptable threshold: Bravo 400S compares the effective rate read by the flowmeter and the one calculated by the pressure sensor.

When the difference between the two rate values exceeds the set percentage, the alarm is triggered.

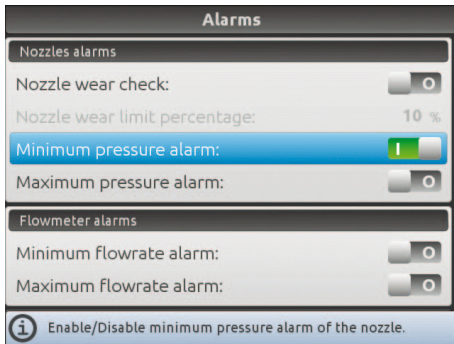


Fig. 110

• Minimum pressure alarm
• Maximum pressure alarm

Allows to enable/disable minimum and maximum pressure alarms for the nozzles in use.

- Select the item you wish to set up.
- Enable/disable the alarm (Alarm enabled / Alarm disabled).
- Repeat the setup for each alarm.

Outside the range set in the **Minimum pressure** / **Maximum pressure** menus (par. 10.1.7 Nozzles data), the computer triggers an alarm.

CONTINUES >>>

FLOWMETER ALARMS



Fig. 111

- Minimum flowrate alarm
- Maximum flowrate alarm

Allows to enable/disable minimum and maximum flowrate alarms for the flowmeter.

- Select the item you wish to set up.
- Enable/disable the alarm (Alarm enabled / Alarm disabled).
- Repeat the setup for each alarm.

Outside the range set in the **Minimum flowrate** / **Maximum flowrate** menus (par. 10.1.3 Flowmeter), the computer triggers an alarm.

REV COUNTER ALARMS

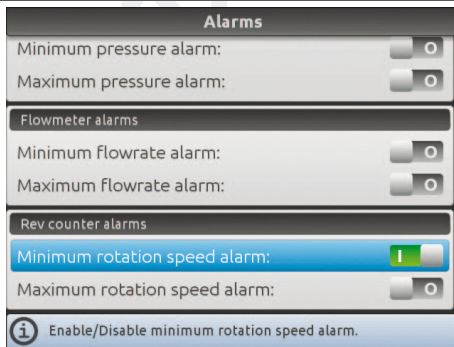


Fig. 112

- Minimum rotation speed alarm
- Maximum rotation speed alarm

Allows to enable/disable minimum and maximum speed alarms for the rev counter.

- Select the item you wish to set up.
- Enable/disable the alarm (Alarm enabled / Alarm disabled).
- Repeat the setup for each alarm.

Outside the range set in the **Minimum rotation speed** / **Maximum rotation speed** menus (par. 10.1.9), the computer triggers an alarm.

10.1.12 Working parameters

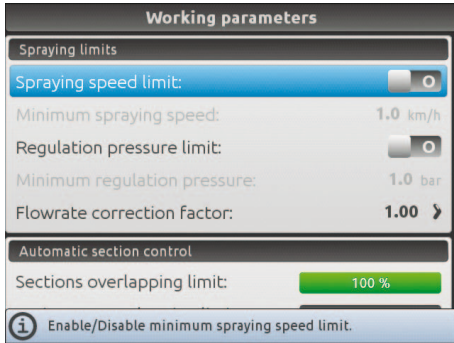


Fig. 113

Set the farming machine job limits.

SPRAYING LIMITS

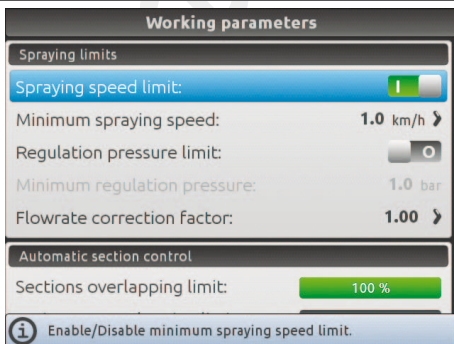


Fig. 114



Fig. 115

• Spraying speed limit

To configure the items on this menu, you must enable the speed limit:

- Limit enabled
- Limit disabled

• Minimum spraying speed

Set the minimum spraying speed: Bravo 400S closes the main valve when the tractor speed is lower than the set value.

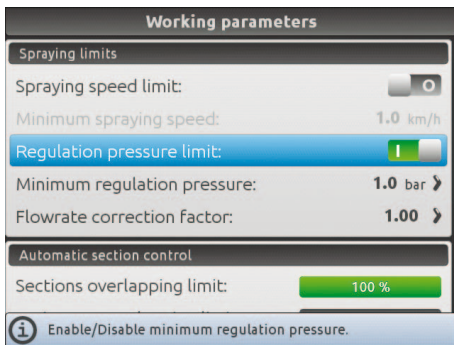


Fig. 116

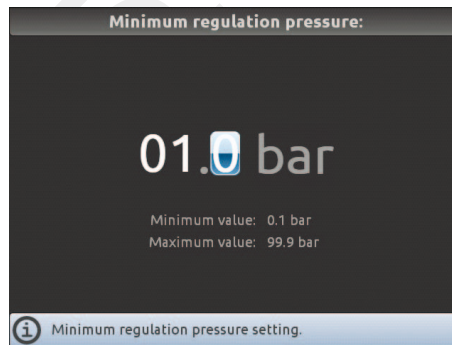


Fig. 117

• Regulation pressure limit

To configure the items on this menu, you must enable the pressure limit:

- Limit enabled
- Limit disabled

• Minimum regulation pressure

Set the minimum spraying pressure: Bravo 400S blocks the automatic regulation of the proportional valve when the pressure is lower than the set value.

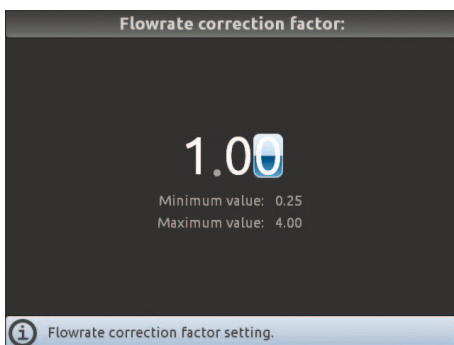


Fig. 118

• Flowrate correction factor

Set the density factor of the sprayed fluid. When using a paddle flowmeter and the sprayed fluid has a different viscosity than that of water, the computer could display wrong measurements; to correct them change the flowrate correction factor:

- if at the end of the spraying the tank still contains fluid, reduce the factor;
- if the fluid finishes before the job has ended, increase the factor.



Flowmeters of the ORION series (code 462xxx) are not affected by the viscosity difference of the fluids: set the factor to 1.00.

CONTINUES >>>

AUTOMATIC SECTION CONTROL

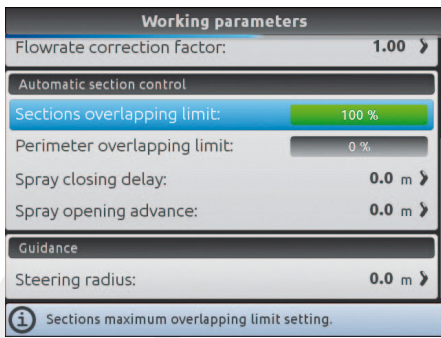


Fig. 119

• Sections overlapping limit

Set the acceptable threshold for overlapping of already-sprayed areas. When this value is exceeded, Bravo 400S restores the correct spraying: depending on the section management mode enabled (par. 13.7 Boom section management), Bravo 400S will prompt the operator to close the relevant valves or proceed to the automatic closing of boom sections.

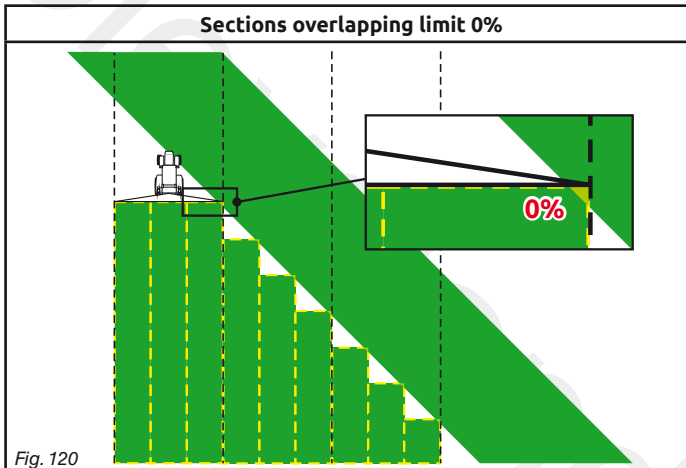


Fig. 120

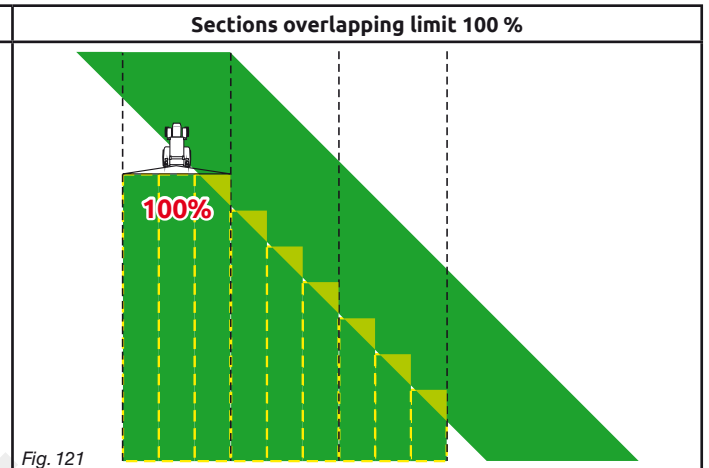


Fig. 121

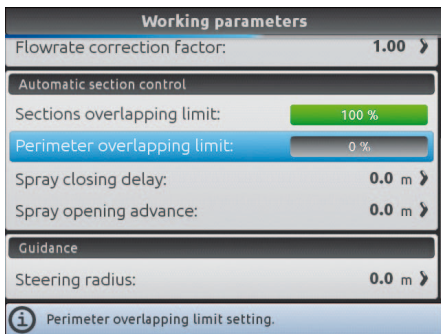


Fig. 122

• Perimeter overlapping limit

Set the acceptable threshold for overlapping of spraying with respect to field perimeter. When this value is exceeded, Bravo 400S restores the correct spraying: Bravo 400S will notify the operator that the section valves spraying outside the field perimeter must be opened or closed.



The following conditions are required in order to use this setup:

- Drawing the field perimeter (red line in the figures) using the function F4 Surface (par. 16.4).
- Enabling automatic section management: the icon on the guidance screen indicates that automatic management is enabled.

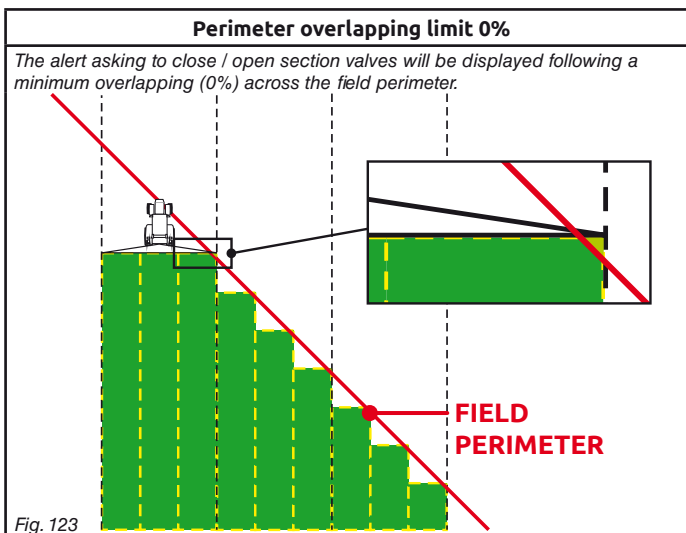


Fig. 123

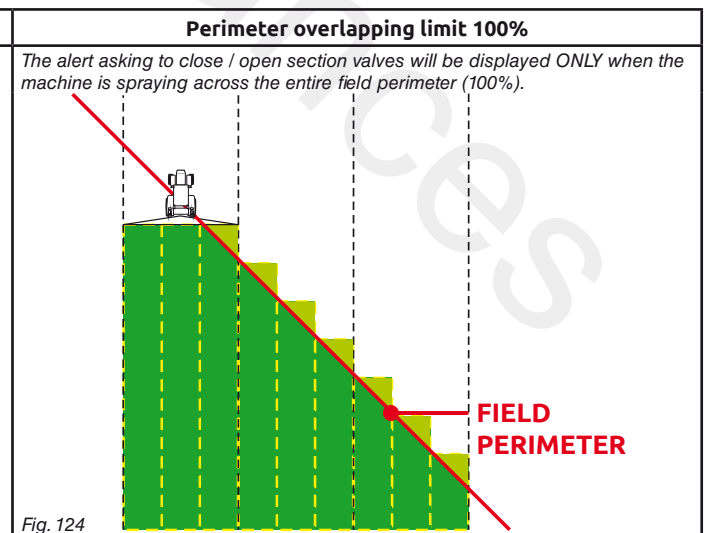


Fig. 124

CONTINUES >>>

• Spray closing delay

Indicate the distance corresponding to the delayed closing of sections during spraying, to ensure correct spraying range.

NOTE: Negative values indicate that sections are closed in advance with respect to the calculated point.

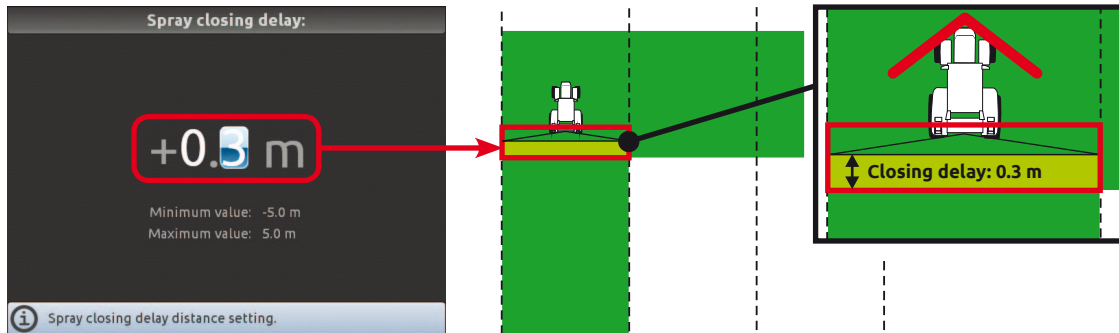


Fig. 125

Fig. 126

• Spray opening advance

Indicate the distance corresponding to the advanced opening of sections during spraying, to ensure correct spraying range.

NOTE: Negative values indicate that section opening is delayed with respect to the calculated point.

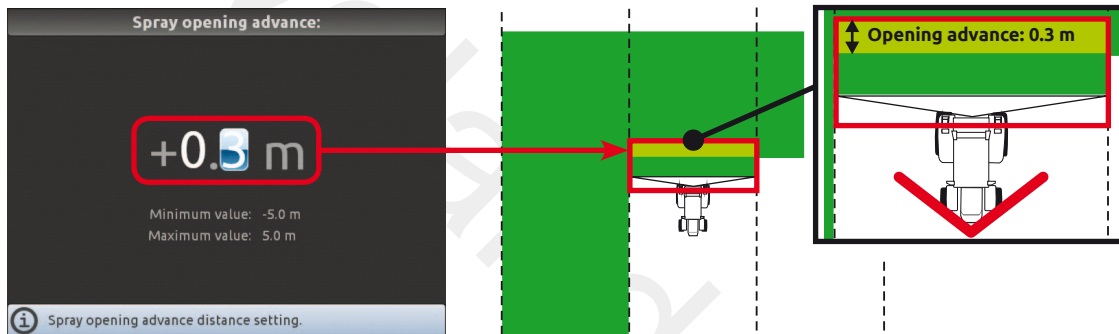


Fig. 127

Fig. 128

GUIDANCE

• Steering radius

By setting this value, an acoustic alarm will indicate the exact moment when the operator must steer in order to align the machine with the following track, avoiding unsprayed or overlapping areas between the two sprays. **The acoustic alarm may be enabled or disabled from the menu User > Steering warning (par. 10.4.4).** This distance should correspond to the implement steering radius (A in Fig. 130), used at the end of the field to change driving direction and resume spraying on the next track, but it will have to be adjusted according to the characteristics of the operator and the speed of the machine.

The alarm is triggered **ONLY** if the direction of the machine is at an angle of more than 85° with respect to the next track.

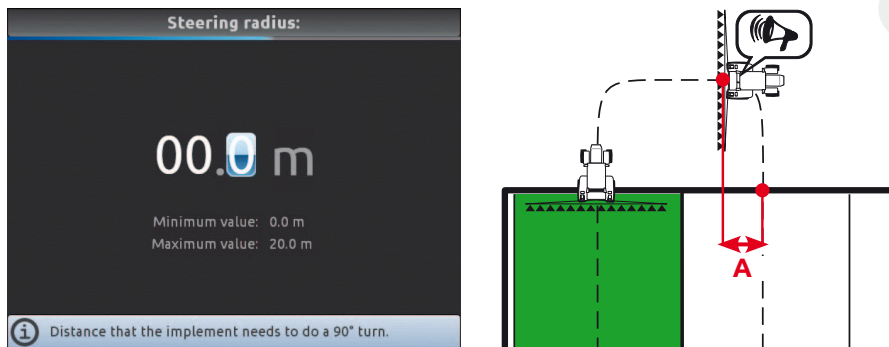


Fig. 129

Fig. 130

10.1.13 Device calibration

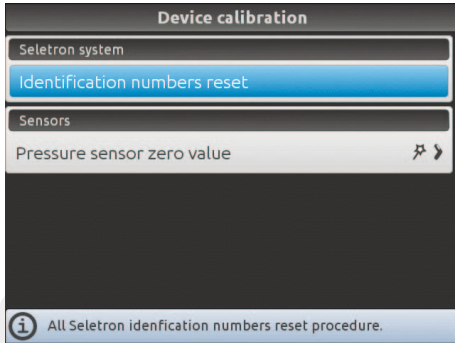


Fig. 131

Allows to start calibration for the devices connected to Bravo 400S.

SELETRON SYSTEM

• Identification numbers reset

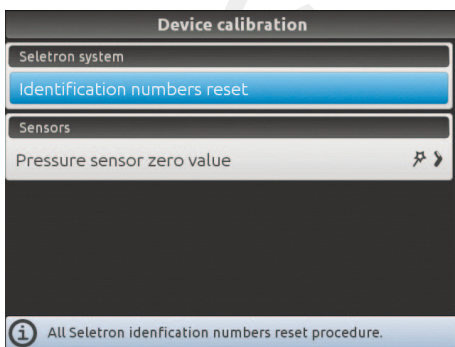


Fig. 132

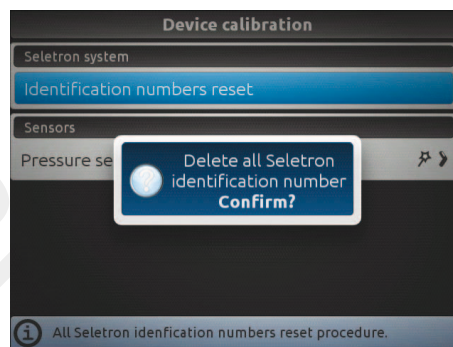


Fig. 133

Allows to reset the identification numbers of all saved Seletrons, before repeating the pairing procedure (chap. 11).

- Select **Identification numbers reset** (Fig. 132) and press **OK**.
- The message in Fig. 133 is displayed: confirm reset by pressing **OK** again.

At the end of the reset procedure, DISCONNECT ALL SELETRONS and start a new pairing procedure (chap. 11).

SENSORS

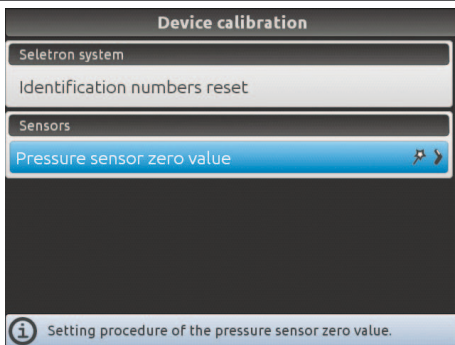


Fig. 134



To access this menu, the pressure sensor must be enabled (, par. 10.1.5)

• Pressure sensor zero value

In case a pressure value other than zero is displayed **despite the absence of pressure inside the circuit**, it is necessary to perform zero calibration of the sensor.



Before carrying out any operation disable the pump by disconnecting it from the power supply. Make sure that the pump is correctly disabled, then open the main valve and all section valves.

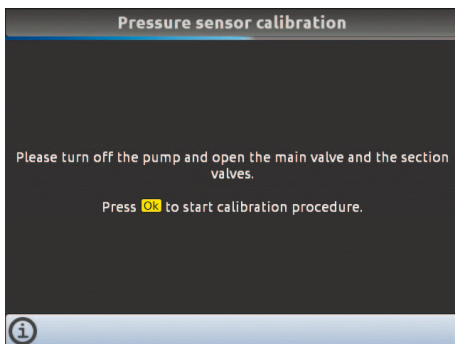


Fig. 135

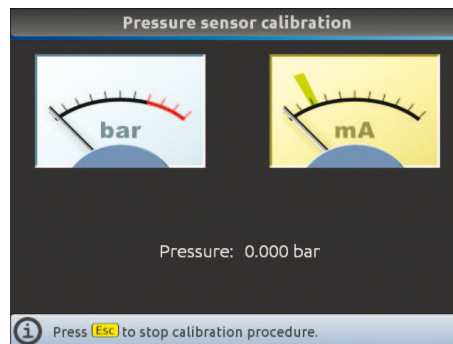


Fig. 136

1 Select **Pressure sensor zero value** (Fig. 134) and press **OK**.

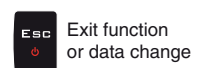
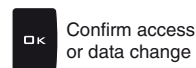
2 The message in Fig. 135 is displayed: follow the instructions, then start the procedure by pressing **OK**.


3 Press **OK** to reset the pressure sensor residual signal.

Value out of range!

If this alarm is displayed, faulty pressure values have been detected: check the sensor operation.

If the problem persists, check for residual pressure in the system.



 The geometry of the displayed implement depends on the selected basic settings (chap. 9).

10.1.14 3-point implement geometry settings (SYSTEM WITH 3-POINT HITCH)

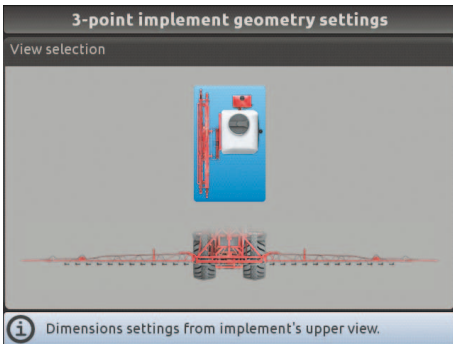


Fig. 137

Enter farming machine measures:

- Press the arrow keys (UP, DOWN, LEFT, RIGHT) to move across different implement views.
- Confirm by pressing **OK** to enter setup.

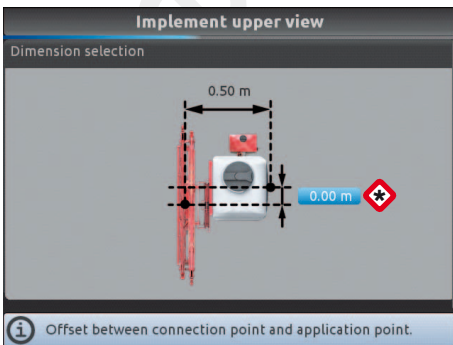


Fig. 138

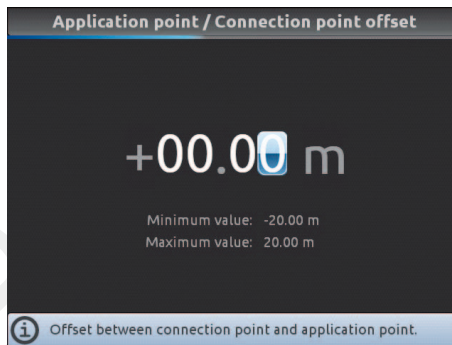


Fig. 139

• Implement upper view

- Press the arrow keys (UP, DOWN, LEFT, RIGHT) to move across values: the description of the selected value will appear on the display.
- Confirm by pressing **OK** to enter setup.
- Enter the value.
- Select and enter, one by one, all values.

 **Offset between connection point and application point**

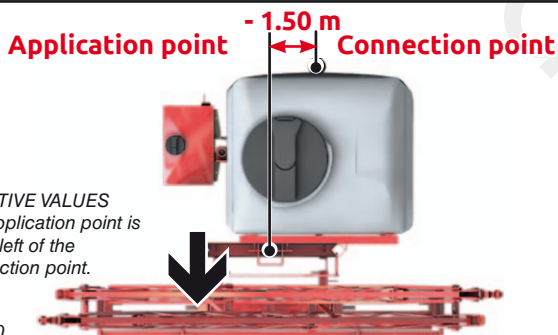


Fig. 140

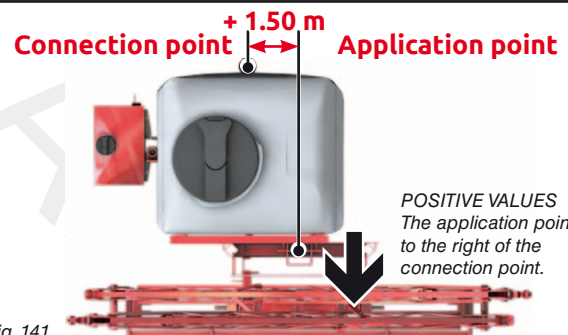


Fig. 141

 THE CONNECTION POINT OF A SELF-PROPELLED MACHINE COINCIDES WITH THE REAR AXLE OF THE VEHICLE.

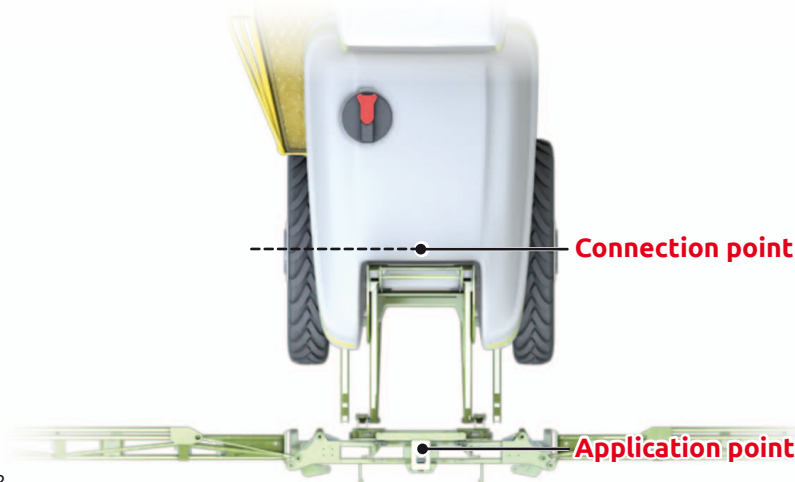


Fig. 142

CONTINUES >>>

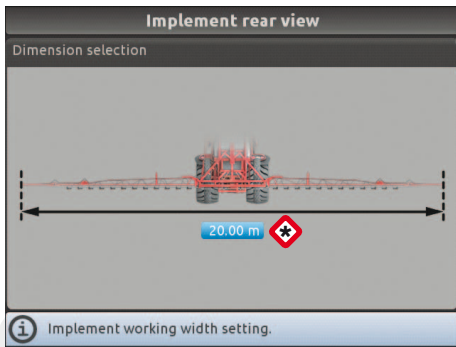


Fig. 143

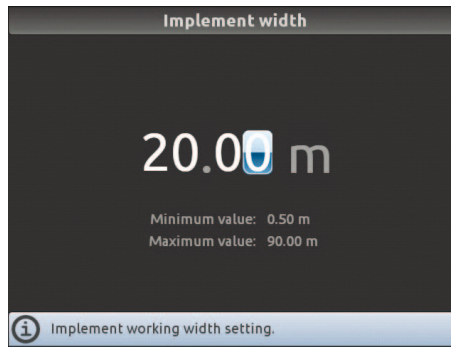


Fig. 144

Implement rear view

- Confirm by pressing **OK** to enter setup.
- Enter the value.

Implement width

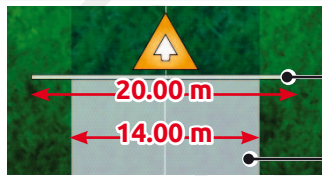



Fig. 145

Implement width

Boom length (sprayed area)

The width set for the implement is shown on the display in the guidance screen: usually it is equal to the boom width, and thus to the covered area diagram.

If you wish to see two different widths displayed on the guidance screen, as in the example of Fig. 145, set the **Implement width** to a different value than the boom width (**Implement > Boom settings** menu, par 10.1.2).

 The geometry of the displayed implement depends on the selected basic settings (chap. 9).

10.1.15 Towed implement geometry settings (SYSTEM WITH TOWING HITCH)

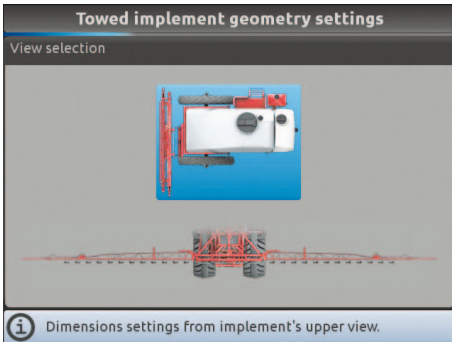


Fig. 146

Enter farming machine measures:

- Press the arrow keys (UP, DOWN, LEFT, RIGHT) to move across different implement views.
- Confirm by pressing **OK** to enter setup.

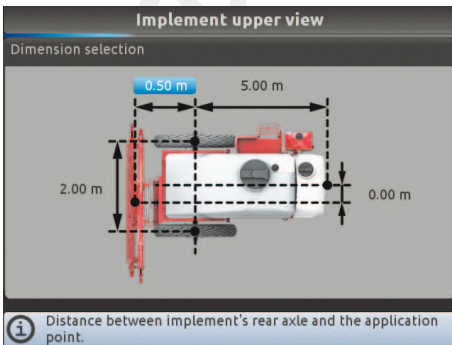


Fig. 147

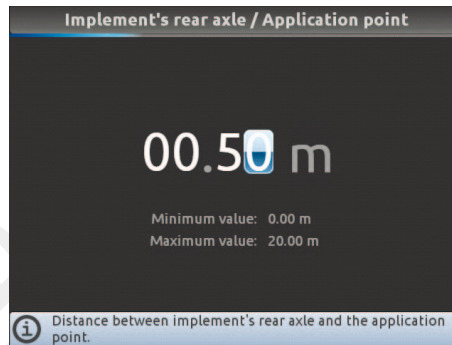


Fig. 148

• Implement upper view

- Press the arrow keys (UP, DOWN, LEFT, RIGHT) to move across values: the description of the selected value will appear on the display.
- Confirm by pressing **OK** to enter setup.
- Enter the value.
- Select and enter, one by one, all values.

 Offset between connection point and application point

Application point - 1.50 m Connection point

Connection point + 1.50 m Application point

NEGATIVE VALUES
The application point is to the left of the connection point.

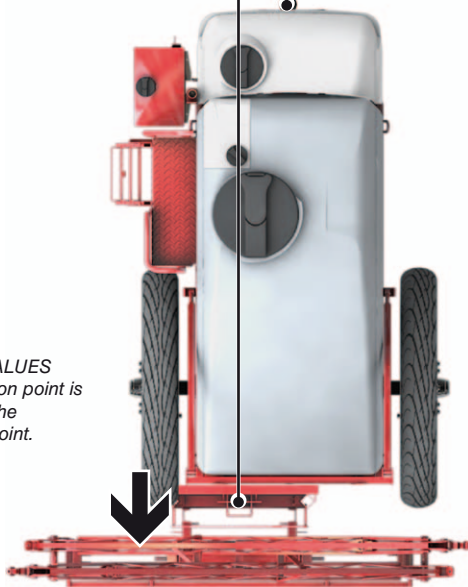


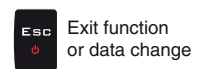
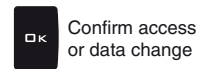
Fig. 149

POSITIVE VALUES
The application point is to the right of the connection point.



Fig. 150

CONTINUES >>>



>>> 10.1.15 Towed implement geometry settings (SYSTEM WITH TOWING HITCH)

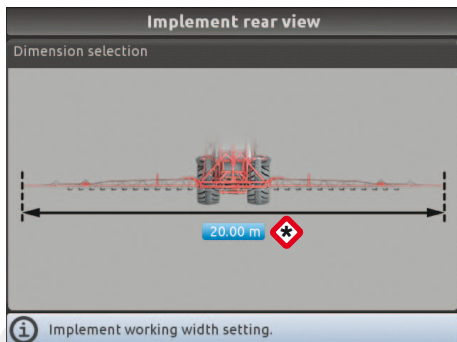


Fig. 151

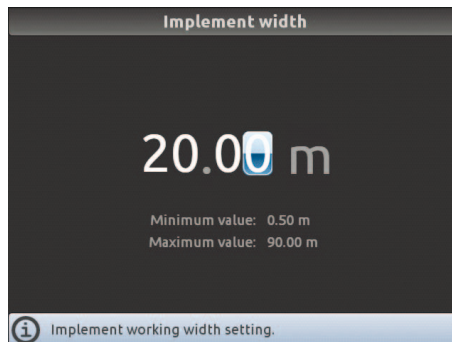


Fig. 152

Implement rear view

- Confirm by pressing **OK** to enter setup.
- Enter the value.

Implement width

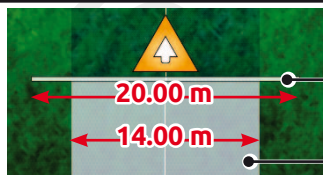


Fig. 153

Implement width

Boom length (sprayed area)

The width set for the implement is shown on the display in the guidance screen: usually it is equal to the boom width, and thus to the covered area diagram.

If you wish to see two different widths displayed on the guidance screen, as in the example of Fig. 153, set the **Implement width** to a different value than the boom width (**Implement > Boom settings** menu, par 10.1.2).

END 10.1.15 Towed implement geometry settings (SYSTEM WITH TOWING HITCH)

F1 Enter selected character

F2 Delete selected character

F7 **F8** Scroll (LEFT / RIGHT)

F4 **F6** Scroll (UP / DOWN)

Value Increase / decrease

OK Confirm access or data change

ESC Exit function or data change

The type of implement displayed depends on the selected basic settings (chap. 9), which affect which items are displayed in Fig. 154.

10.2 Implement - GPS GUIDANCE MONITOR

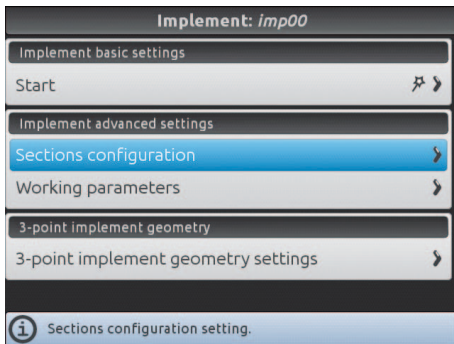


Fig. 154

Implement advanced settings

- Sections configuration (par. 10.2.1).
- Working parameters (par. 10.2.2).

Implement geometry

- 3-point implement geometry settings (par. 10.2.3).
- Towed implement geometry settings (par. 10.2.4).

10.2.1 Sections configuration

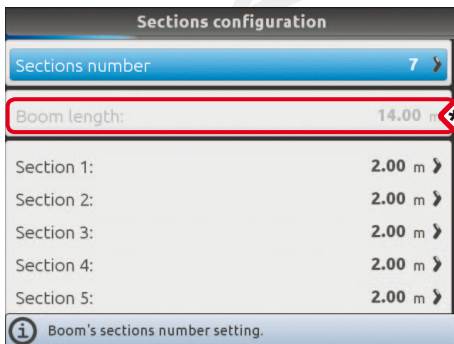


Fig. 155

The boom width value displayed in Fig. 155 will vary depending on the selected setup.

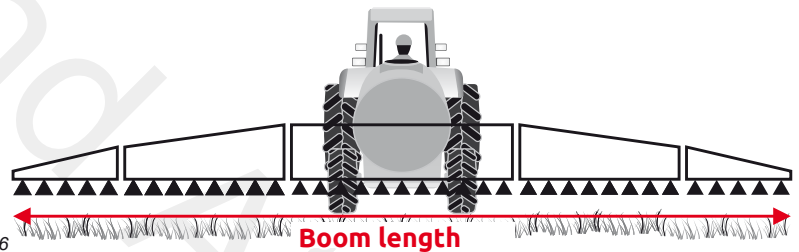
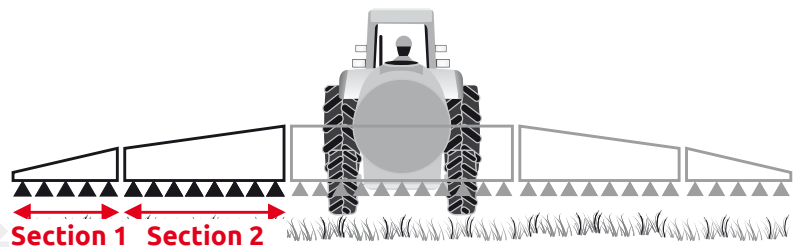


Fig. 156

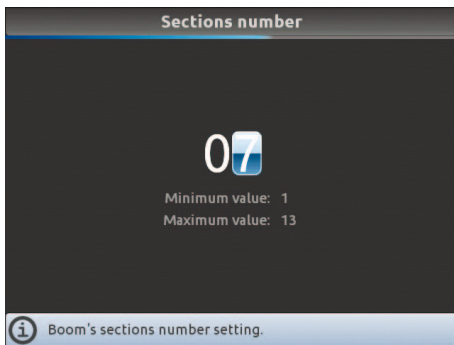


Fig. 157

Sections number

Indicate the total number of boom sections.

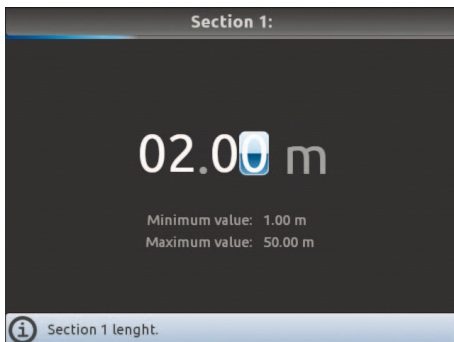
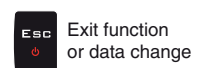
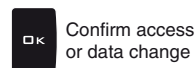


Fig. 158

Section 1 ÷ 13

- Indicate the width of each boom section.
- Repeat the setup for each section (Fig. 155).



10.2.2 Working parameters

Set the farming machine job limits.

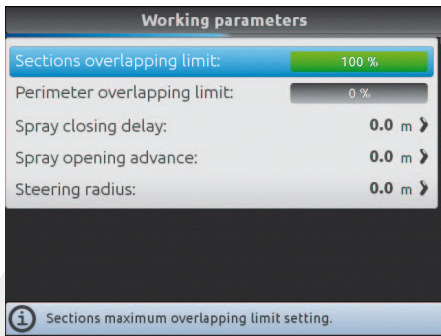


Fig. 159

• Sections overlapping limit

Set the acceptable threshold for overlapping of already-sprayed areas. When this value is exceeded, Bravo 400S restores the correct spraying: depending on the section management mode enabled (par. 13.7 Boom section management), Bravo 400S will prompt the operator to close the relevant valves or proceed to the automatic closing of boom sections.

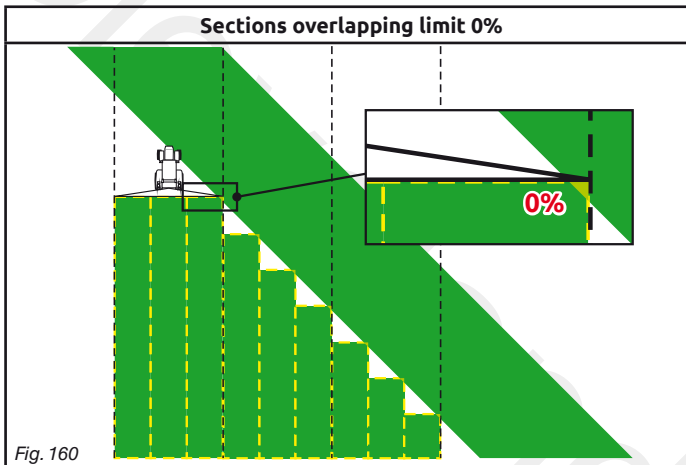


Fig. 160

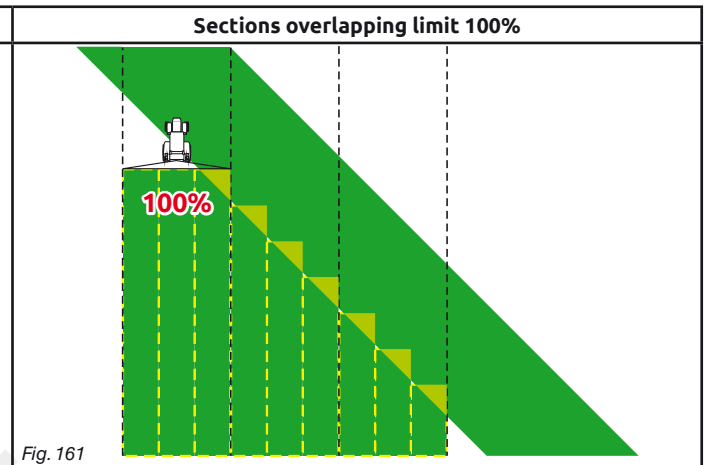


Fig. 161

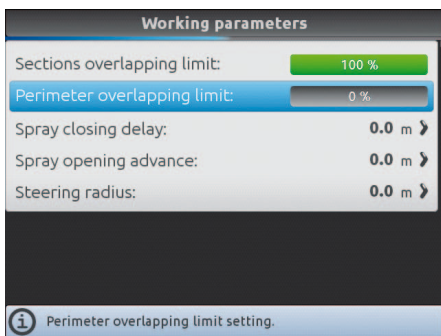



Fig. 162

• Perimeter overlapping limit

Set the acceptable threshold for overlapping of spraying with respect to field perimeter. When this value is exceeded, Bravo 400S restores the correct spraying: Bravo 400S will notify the operator that the section valves spraying outside the field perimeter must be opened or closed.



- The following conditions are required in order to use this setup:
- Drawing the field perimeter (red line in the figures) using the function F4 Surface (par. 16.4).
 - Enabling automatic section management: the icon  on the guidance screen indicates that automatic management is enabled.

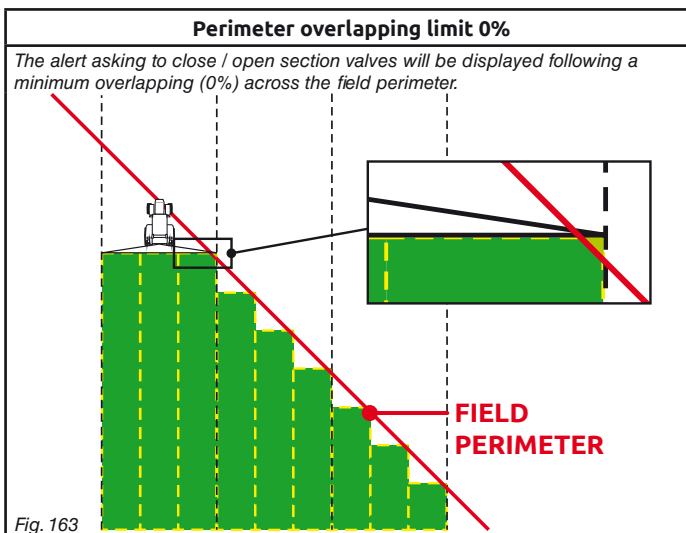


Fig. 163

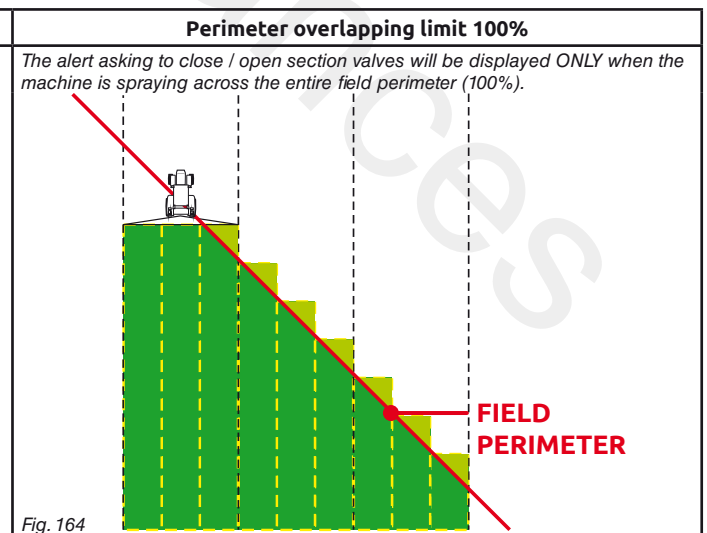


Fig. 164

CONTINUES >>>

• Spray closing delay

Indicate the distance corresponding to the delayed closing of sections during spraying, to ensure correct spraying range.

NOTE: Negative values indicate that sections are closed in advance with respect to the calculated point.

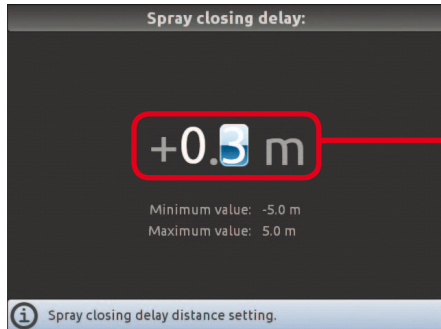


Fig. 165

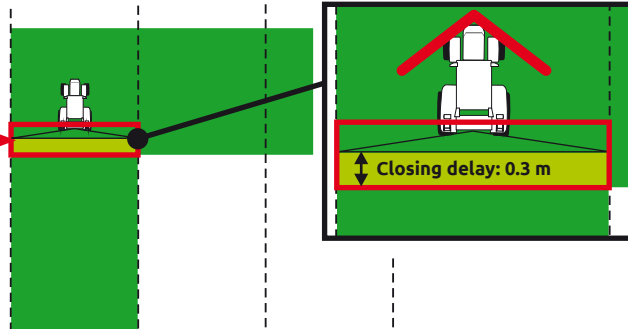


Fig. 166

• Spray opening advance

Indicate the distance corresponding to the advanced opening of sections during spraying, to ensure correct spraying range.

NOTE: Negative values indicate that section opening is delayed with respect to the calculated point.

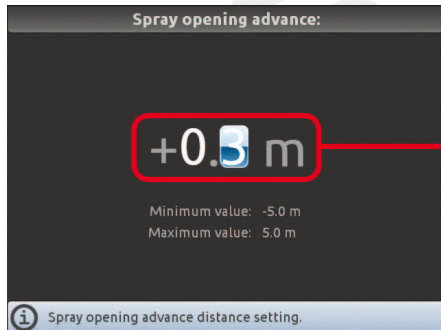


Fig. 167

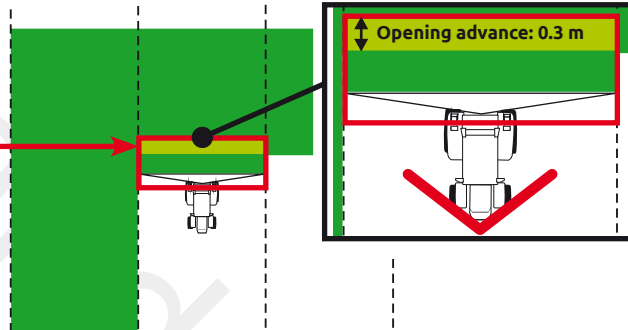


Fig. 168

• Steering radius

By setting this value, an acoustic alarm will indicate the exact moment when the operator must steer in order to align the machine with the following track, avoiding unsprayed or overlapping areas between the two sprays.

This distance should correspond to the implement steering radius (A in Fig. 170), used at the end of the field to change driving direction and resume spraying on the next track, but it will have to be adjusted according to the characteristics of the operator and the speed of the machine.

The alarm is triggered ONLY if the direction of the machine is at an angle of more than 85° with respect to the next track.

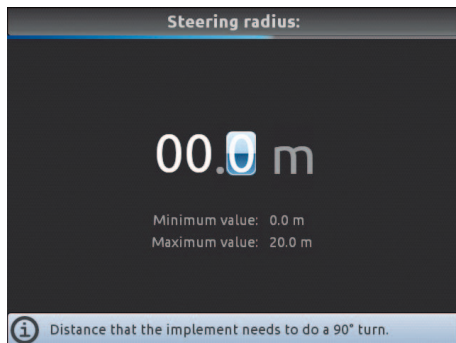


Fig. 169

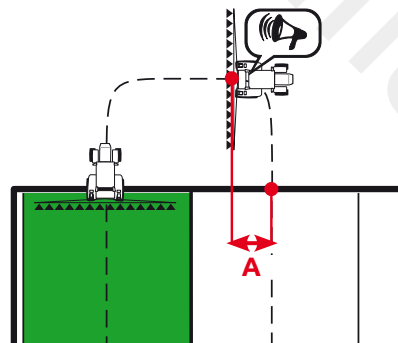


Fig. 170

The geometry of the displayed implement depends on the selected basic settings (chap. 9).

10.2.3 3-point implement geometry settings (SYSTEM WITH 3-POINT HITCH)

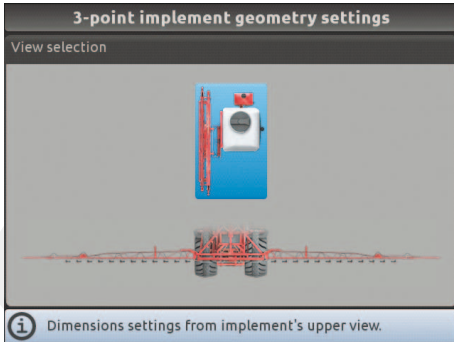


Fig. 171

Enter farming machine measures:
 - Press the arrow keys (UP, DOWN, LEFT, RIGHT) to move across different implement views.
 - Confirm by pressing **OK** to enter setup.

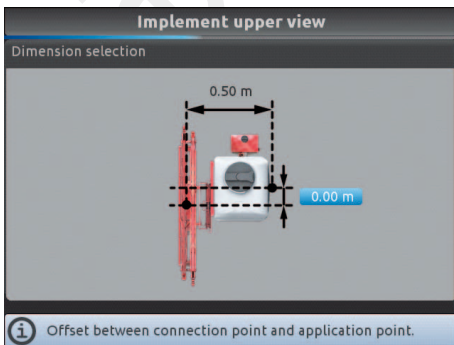


Fig. 172

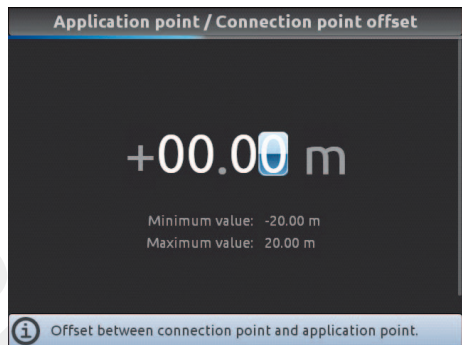


Fig. 173

• Implement upper view

- Press the arrow keys (UP, DOWN, LEFT, RIGHT) to move across values: the description of the selected value will appear on the display.
 - Confirm by pressing **OK** to enter setup.
 - Enter the value.
 - Select and enter, one by one, all values.

⊕ Offset between connection point and application point

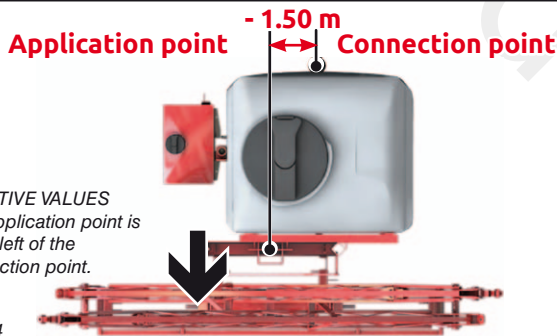


Fig. 174

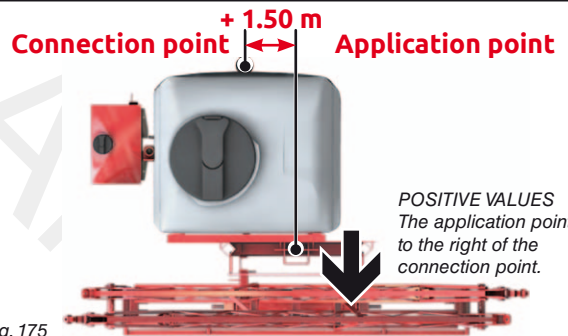


Fig. 175

THE CONNECTION POINT OF A SELF-PROPELLED MACHINE COINCIDES WITH THE REAR AXLE OF THE VEHICLE.

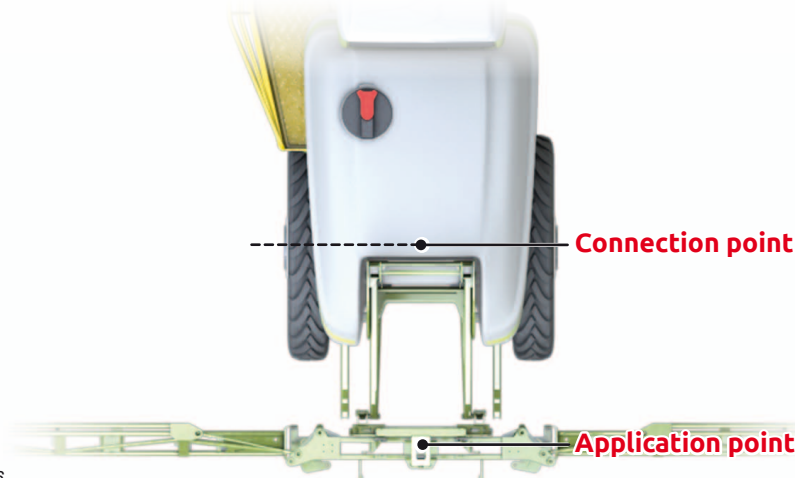


Fig. 176

CONTINUES >>>

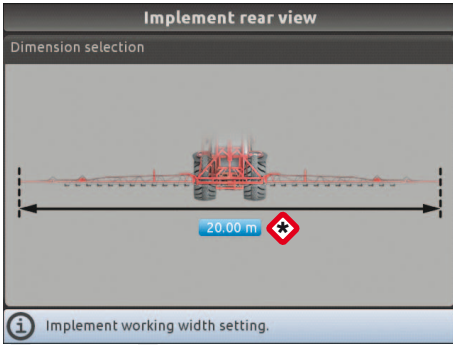


Fig. 177

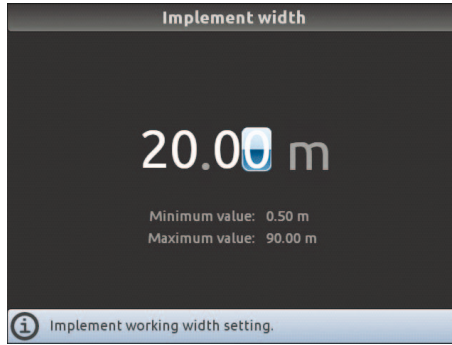


Fig. 178

Implement rear view

- Confirm by pressing **OK** to enter setup.
- Enter the value.

Implement width

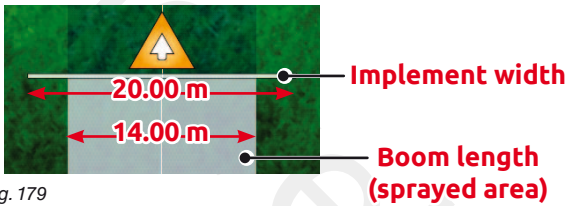



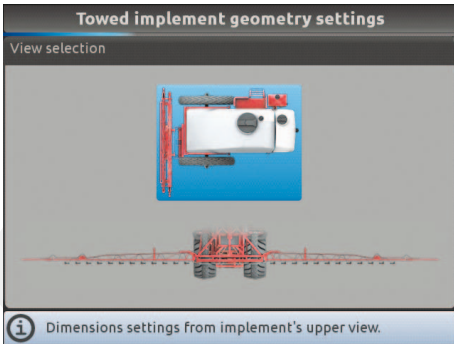
Fig. 179

The width set for the implement is shown on the display in the guidance screen: usually it is equal to the boom width, and thus to the covered area diagram.

If you wish to see two different widths displayed on the guidance screen, as in the example of Fig. 179, set the **Implement width** to a different value than the boom width (**Implement > Sections configuration** menu, par 10.2.1).

 The geometry of the displayed implement depends on the selected basic settings (chap. 9).

10.2.4 Towed implement geometry settings (SYSTEM WITH TOWING HITCH)



Enter farming machine measures:
 - Press the arrow keys (UP, DOWN, LEFT, RIGHT) to move across different implement views.
 - Confirm by pressing **OK** to enter setup.

Fig. 180

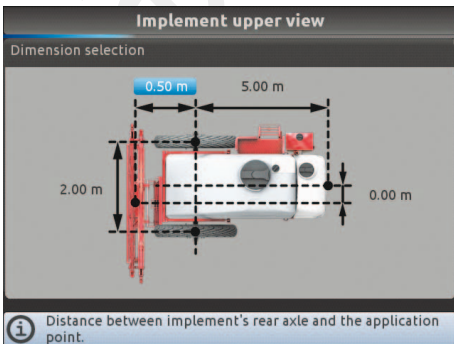


Fig. 181

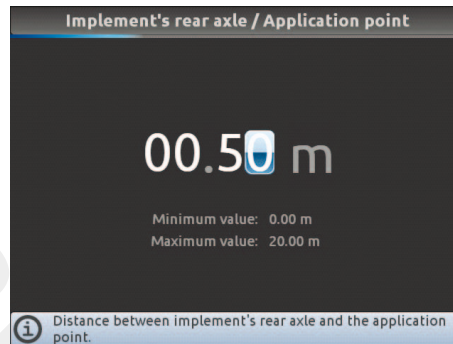
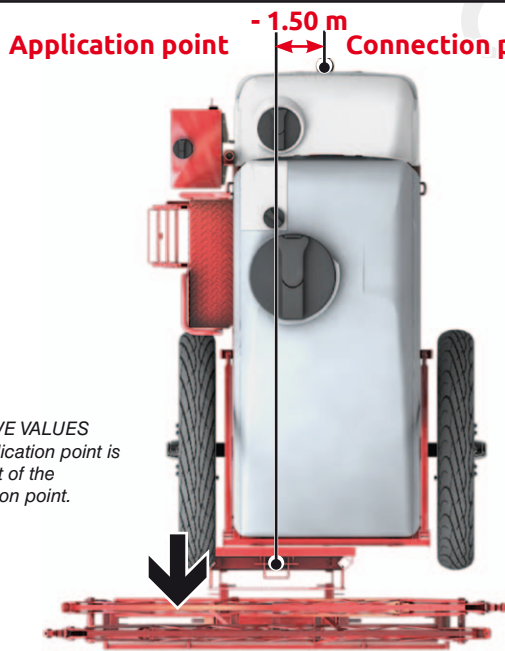


Fig. 182

Implement upper view

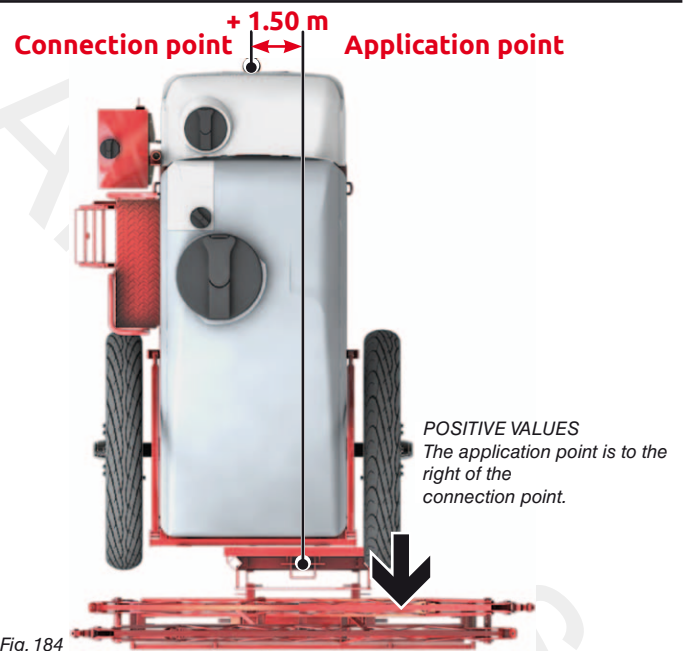
- Press the arrow keys (UP, DOWN, LEFT, RIGHT) to move across values: the description of the selected value will appear on the display.
- Confirm by pressing **OK** to enter setup.
- Enter the value.
- Select and enter, one by one, all values.

 **Offset between connection point and application point**



NEGATIVE VALUES
 The application point is to the left of the connection point.

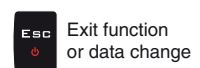
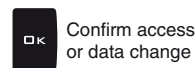
Fig. 183



POSITIVE VALUES
 The application point is to the right of the connection point.

Fig. 184

CONTINUES >>>



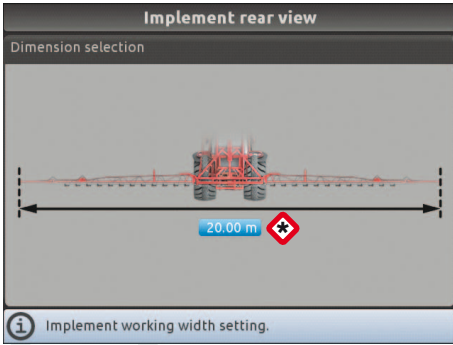


Fig. 185

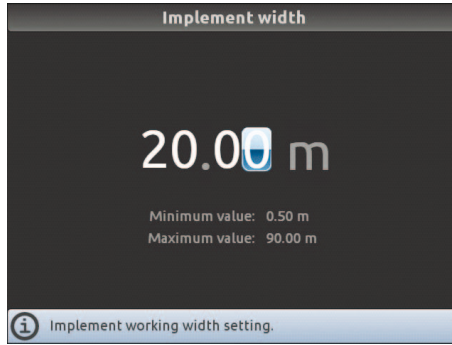


Fig. 186

Implement rear view

- Confirm by pressing **OK** to enter setup.
- Enter the value.

Implement width

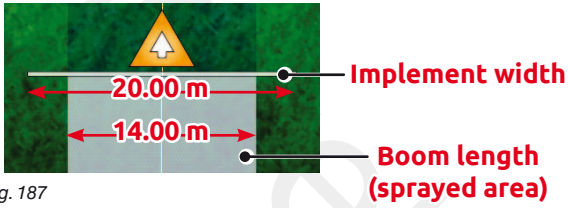



Fig. 187

The width set for the implement is shown on the display in the guidance screen: usually it is equal to the boom width, and thus to the covered area diagram.

If you wish to see two different widths displayed on the guidance screen, as in the example of Fig. 187, set the **Implement width** to a different value than the boom width (**Implement > Sections configuration** menu, par 10.2.1).

10.3 Tractor

 The tractor setup depends on the selected basic settings (chap. 9), which affect which items are displayed in Fig. 188.

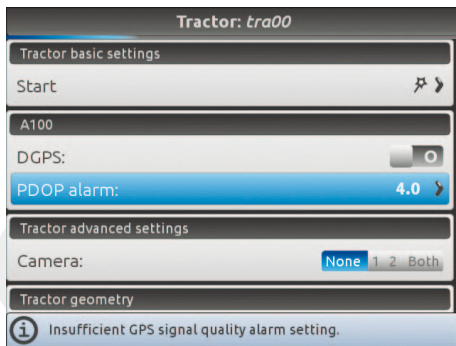


Fig. 188

A100 / GPS receiver

- **DGPS** (par. 10.3.1).
- **PDOP / HDOP alarm** (par. 10.3.2).

Tractor advanced settings

- **Camera** (par. 10.3.3).

Tractor geometry

- **Tractor geometry settings** (par. 10.3.4).

10.3.1 DGPS

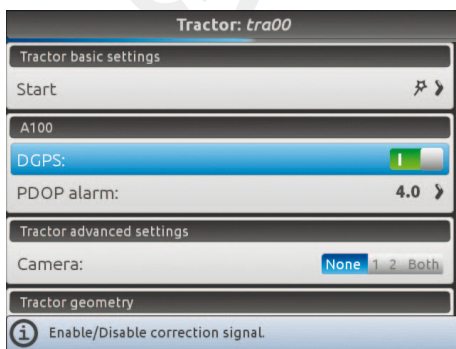


Fig. 189

Allows to enable / disable the DGPS (SBAS) differential correction function

 **DGPS correction enabled** /  **DGPS correction disabled**.

The SBAS differential correction signal is free of charge and available only in some areas of the world. This signal allows to obtain a more accurate spraying.

 **WARNING: this function may be used only in Europe (EGNOS), the United States (WAAS) and Japan (MSAS).**

10.3.2 PDOP / HDOP alarm

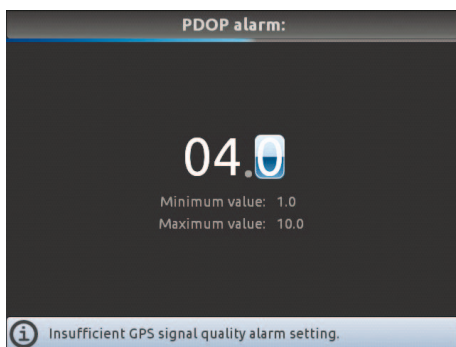


Fig. 190

"PDOP" and "HDOP" are parameters that depend on the position and number of satellites in space that affect the positional precision of the system (longitude and latitude); the lower the value, the higher is the driving precision.

The precision alarm is triggered when the value of PDOP or HDOP measured by the GPS receiver is above the set limit. **We recommend NOT to set values above 4.0.**

10.3.3 Camera

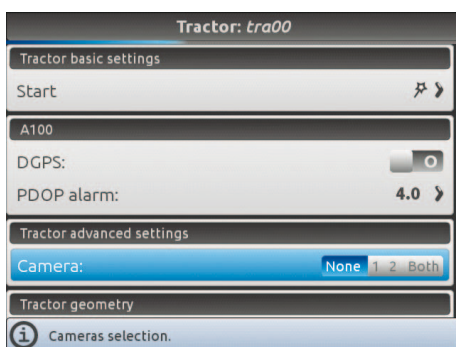
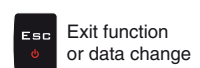
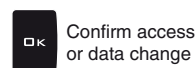


Fig. 191

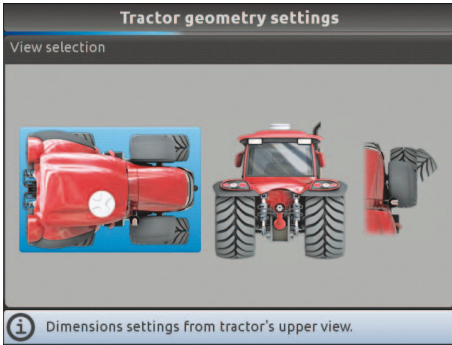
It is possible to connect up to 2 cameras to Bravo 400S in order to monitor the working areas that the operator is unable to see (e.g., when driving in reverse).

From the menu it is possible to enable/disable each single camera individually or both cameras:

- None** No camera connected
- 1** 1 camera connected to input no.1
- 2** 1 camera connected to input no.2
- Both** 2 cameras connected



10.3.4 Tractor geometry settings

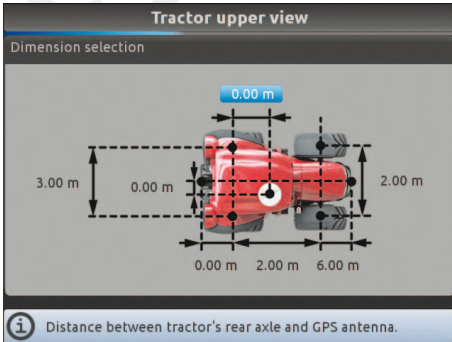


Dimensions settings from tractor's upper view.

Fig. 192

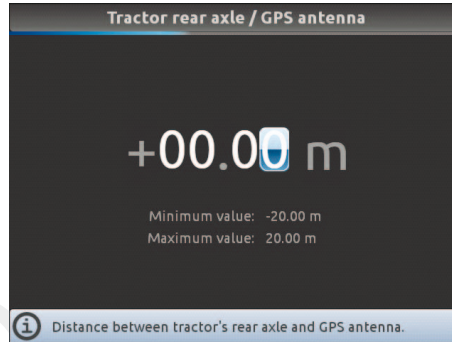
Enter farming machine measures:

- Press the arrow keys (UP, DOWN, LEFT, RIGHT) to move across different tractor views.
- Confirm by pressing **OK** to enter setup.



Distance between tractor's rear axle and GPS antenna.

Fig. 193



Distance between tractor's rear axle and GPS antenna.

Fig. 194

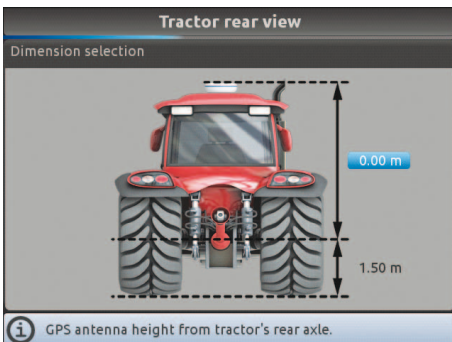
• Tractor upper view

- Press the arrow keys (UP, DOWN, LEFT, RIGHT) to move across values: the description of the selected value will appear on the display.
- Confirm by pressing **OK** to enter setup.
- Enter the value.
- Select and enter, one by one, all values.



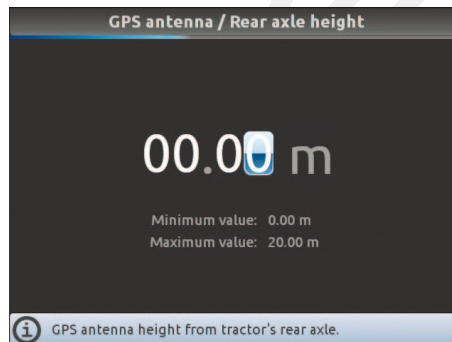
Fig. 195

THE CONNECTION POINT OF A SELF-PROPELLED MACHINE COINCIDES WITH THE REAR AXLE OF THE VEHICLE.



GPS antenna height from tractor's rear axle.

Fig. 196



GPS antenna height from tractor's rear axle.

Fig. 197

• Tractor rear view

- Press the arrow keys (UP, DOWN, LEFT, RIGHT) to move across values: the description of the selected value will appear on the display.
- Confirm by pressing **OK** to enter setup.
- Enter the value.
- Select and enter, one by one, all values.



Maximum wheels steering angle.

Fig. 198

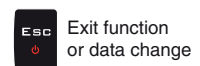
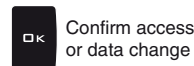


Maximum wheels steering angle.

Fig. 199

• Steering angle

- Press **OK** to enter maximum steering angle setup.
- Enter the value.



10.4 User

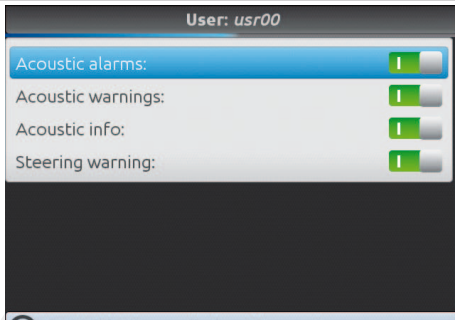


Fig. 200

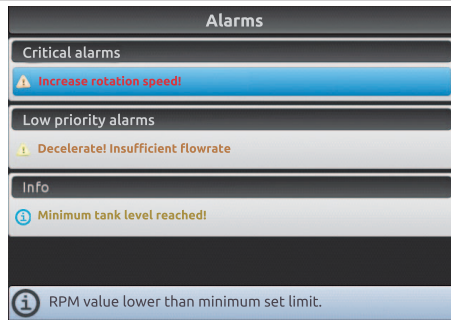


Fig. 201

Bravo 400S features an **Alarms** menu (Fig. 201, accessible from the "Home" menu by pressing **F6**). This page displays all active notifications for the operator. These notifications are rated by importance as **Critical alarms**, **Low priority alarms** and **Info**.

From the **User** menu it is possible to enable / disable acoustic alarms for each notification:

- **Acoustic alarms** (par. 10.4.1).
- **Acoustic warnings** (par. 10.4.2).
- **Acoustic info** (par. 10.4.3).
- **Steering warning** (par. 10.4.4).

10.4.1 Acoustic alarms

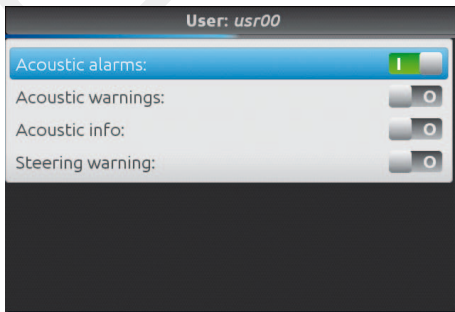


Fig. 202

Allows to enable/disable the acoustic signal when new **Alarms** (Fig. 201) are triggered.

- Signal enabled
- Signal disabled

10.4.2 Acoustic warnings

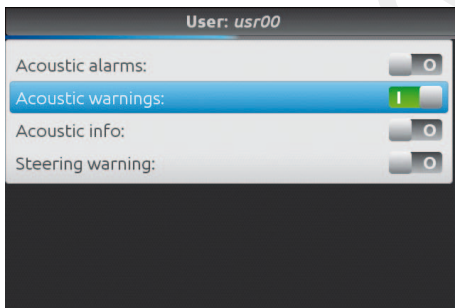


Fig. 203

Allows to enable/disable the acoustic signal when new **Low priority alarms** (Fig. 201) are triggered.

- Signal enabled
- Signal disabled

10.4.3 Acoustic info

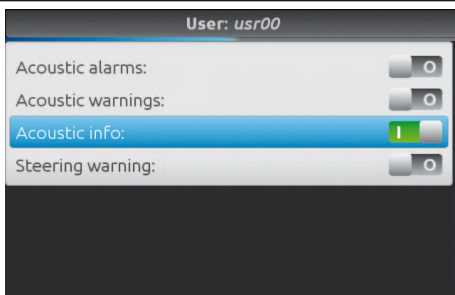


Fig. 204

Allows to enable/disable the acoustic signal when new **Info** (Fig. 201) are triggered.

- Signal enabled
- Signal disabled

10.4.4 Steering warning

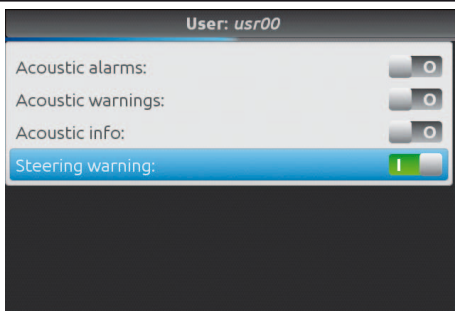


Fig. 205

Allows to enable/disable the acoustic signal when the operator must steer in order to align the machine with the following track, avoiding unsprayed or overlapping areas between the two sprays (**Steering radius** set in par. 10.1.12 or 10.2.2 Working parameters).

- Signal enabled
- Signal disabled

10.5 General options

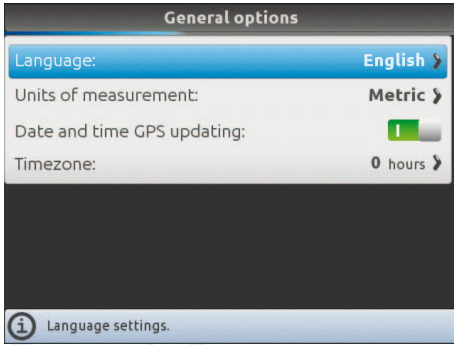


Fig. 206

Set the device system options:

- **Language** (par. 10.5.1).
- **Units of measurement** (par. 10.5.2).
- **Date and time GPS updating** (par. 10.5.3).
- **Timezone** (par. 10.5.4).
- **Date and time** (par. 10.5.5).

10.5.1 Language

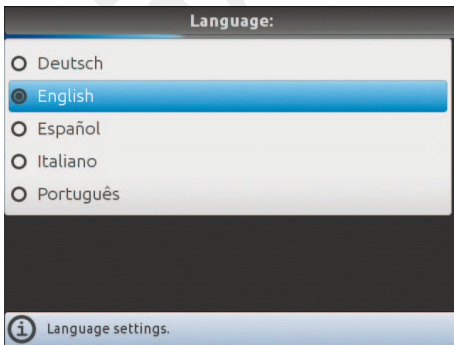


Fig. 207

Set the computer language.

10.5.2 Units of measurement

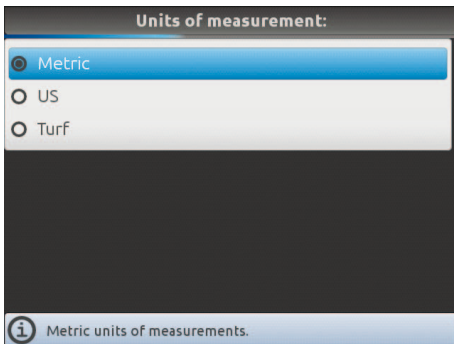


Fig. 208

Set the computer units of measurement:

- **Metric:** km/h, l/ha, l/min, bar, etc...
- **US:** MPH, GPA, GPM, PSI, etc...
- **Turf:** MPH, GPK, GPM, PSI, etc...

10.5.3 Date and time GPS updating

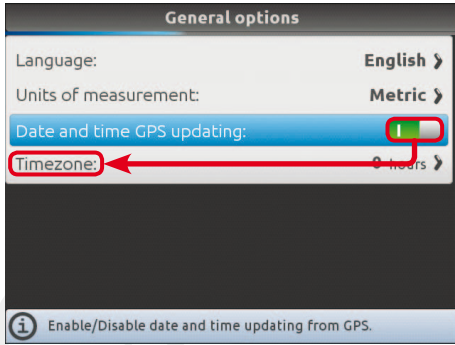


Fig. 209

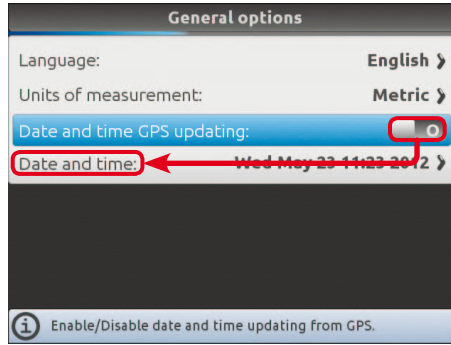


Fig. 210

Allows to enable / disable computer automatic date and time updating.

Updating enabled
The local time and date will be constantly updated thanks to the signal picked up by the GPS receiver.

The display will show the menu **Timezone** (Fig. 209).

Updating disabled
Set date and time manually.
The display will show the menu **Date and time** (Fig. 210).

10.5.4 Timezone

To configure this menu, you must enable **Date and time GPS updating** (Fig. 209).

Now set your local timezone with respect to Greenwich Mean Time*.

The local time will be constantly updated thanks to the signal picked up by the GPS receiver.

* List of the main timezones:

United Kingdom, Portugal, Liberia	0	Central Europe (Germany, France, Italy)	+1
Azores	-1	Latvia, Lithuania, Romania, Greece, Israel	+2
Mid-Atlantic islands	-2	Western Russia, Iraq	+3
Argentina, Brazil	-3	United Arab Emirates	+4
AST (USA), Venezuela	-4	Pakistan	+5
EST (USA), Colombia	-5	Kazakhstan	+6
CST (USA), Eastern Mexico	-6	Thailand	+7
MST (USA)	-7	China, Western Australia	+8
PST (USA)	-8	Japan	+9
AKST (USA)	-9	Eastern Australia	+10
HST (USA), Hawaii	-10	Eastern Russia	+11
Midway Islands	-11	Fiji Islands, New Zealand	+12
Enewetak	-12		

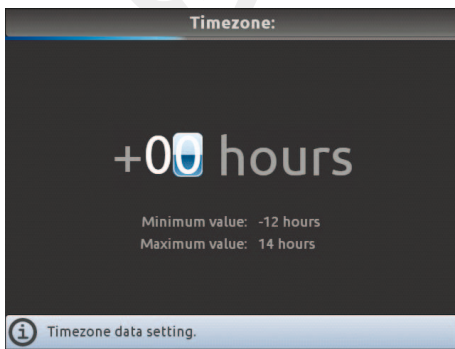


Fig. 211

10.5.5 Date and time

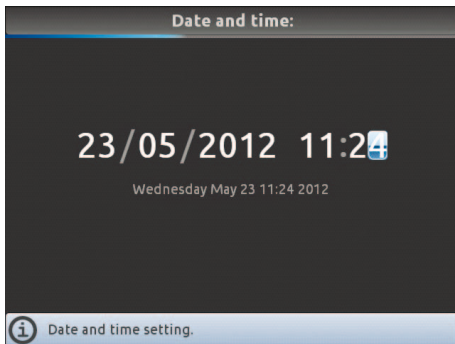


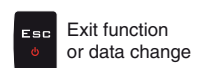
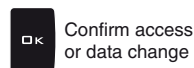
Fig. 212

To configure the items on this menu, you must disable **Date and time GPS updating** (Fig. 210).

Now set the computer time.



Value Increase / decrease



 The aspect of this menu depends on the selected basic settings (chap. 9), which affect which items are displayed in Fig. 213.

10.6 Device status - SPRAYER (SELETRON)

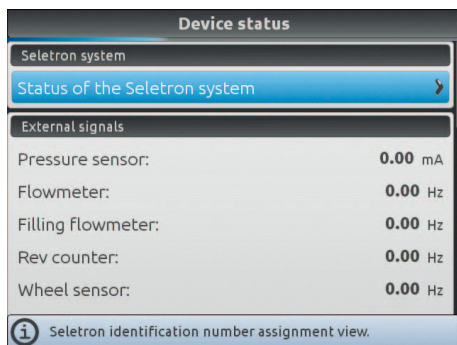


Fig. 213

Allows checking the correct operation of Bravo 400S: the description of the selected item will appear on the display.



Displayed items are READ-ONLY.

SELETRON SYSTEM

• Status of the Seletron system

This menu has two main functions:

• **INSTALLATION**




Allows to display the progress during Seletron's pairing procedure (chap. 11 Seletron connection).

• **DIAGNOSTICS**

Allows to check the connection of each single Seletron.

SELETRON CONNECTION DIAGNOSTICS

Color legend:

-  Correct operation.
-  Seletron does not respond.
-  Power supply error on Seletron devices: power voltage lower than the allowed value.

The screen in Fig. 214 shows the corresponding number: select the Seletron device by using the arrow keys (UP, DOWN, RIGHT, LEFT).

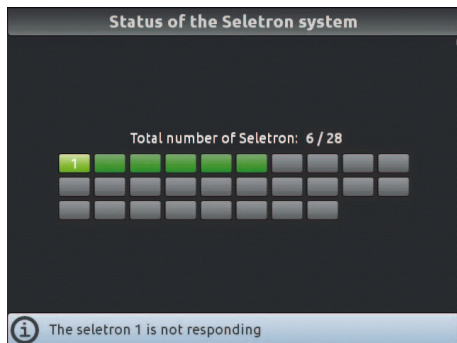









Fig. 214



If necessary, you can and repeat the pairing procedure for each Seletron device: **BEFORE STARTING A NEW PAIRING PROCEDURE, YOU MUST RESET THE PREVIOUSLY ALLOCATED IDENTIFICATION NUMBERS.** Use the function Identification numbers reset (par. 10.1.13).

CONTINUES >>>

 Enter selected character	 Delete selected character	 Scroll (LEFT / RIGHT)	 Scroll (UP / DOWN)	Value Increase / decrease	 Confirm access or data change	 Exit function or data change	 Par. 7.4
---	---	---	--	---------------------------	--	--	--

EXTERNAL SIGNALS

Device status	
Seletron system	
Status of the Seletron system	
External signals	
Pressure sensor:	0.00 mA
Flowmeter:	0.00 Hz
Filling flowmeter:	0.00 Hz
Rev counter:	0.00 Hz
Wheel sensor:	0.00 Hz
Current signal value of the pressure sensor.	

Fig. 215

Bravo 400S detects frequency and current sent by each sensor on the system.

Device status	
Pressure sensor:	0.00 mA
Flowmeter:	0.00 Hz
Filling flowmeter:	0.00 Hz
Rev counter:	0.00 Hz
Wheel sensor:	0.00 Hz
External command:	On
Power data	
Internal battery voltage:	4.15 V
Internal battery temperature:	34 °C
Status of the external command signal.	

Fig. 216

Bravo 400S displays the status of the external main control which starts the spraying.

POWER DATA

Device status	
Wheel sensor:	0.00 Hz
External command:	On
Power data	
Internal battery voltage:	4.16 V
Internal battery temperature:	27 °C
Internal battery capacity:	95 %
Power supply status:	online
Charging status:	Charging
Power supply voltage:	12.18 V
Internal battery voltage level.	

Fig. 217

Device status	
Internal battery temperature:	27 °C
Internal battery capacity:	95 %
Power supply status:	online
Charging status:	Charging
Power supply voltage:	12.19 V
Sensors and motor valves line current:	0.09 A
Boom line 1 current:	0.09 A
Boom line 2 current:	0.09 A
Hydraulic line current:	0.09 A
Current consumption of boom line number 1.	

Fig. 218

Bravo 400S checks the status of the power supply.

FIRMWARE VERSIONS

Device status	
Boom line 1 current:	0.09 A
Boom line 2 current:	0.09 A
Hydraulic line current:	0.09 A
Firmware versions	
OS version:	1.20.0
BOOT version:	1.12.0
RCU:	1.0.3 beta
Switchbox:	-
Operating system version.	

Fig. 219

Bravo 400S displays firmware versions.

 The aspect of this menu depends on the selected basic settings (chap. 9), which affect which items are displayed in Fig. 220.

10.7 Device status - GPS GUIDANCE MONITOR

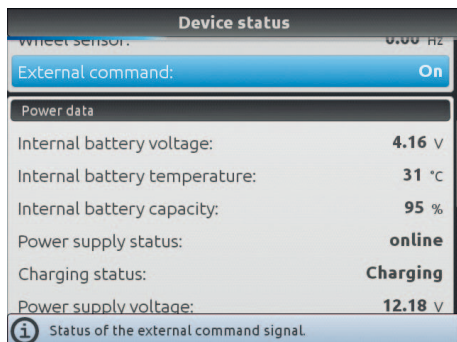



Fig. 220

Allows checking the correct operation of Bravo 400S: the description of the selected item will appear on the display.

 Displayed items are READ-ONLY.

EXTERNAL SIGNALS

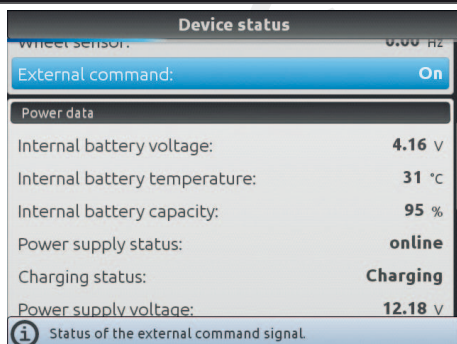


Fig. 221

Bravo 400S displays the status of the external main control which starts the spraying.

POWER DATA

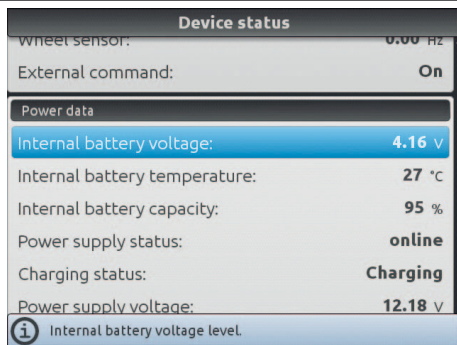


Fig. 222

Bravo 400S checks the status of the power supply.

FIRMWARE VERSIONS

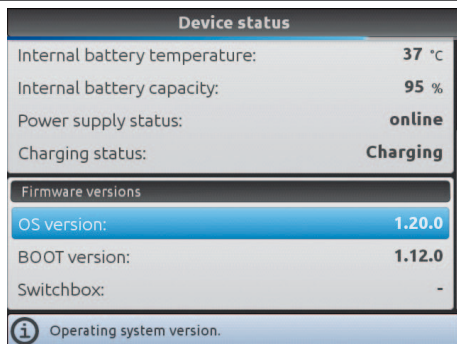
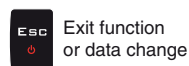
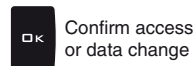


Fig. 223

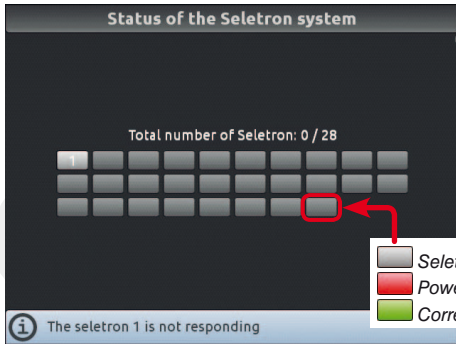
Bravo 400S displays firmware versions.



11 SELETRON CONNECTION



BEFORE PROCEEDING, MAKE SURE YOU ARE ABLE TO HEAR THE ACOUSTIC SIGNALS COMING FROM THE MONITOR LOCATED IN THE CABIN (ENGINE OFF, DOORS OPEN, ETC.)




- Access the menu **Settings > Device status > Status of the Seletron system** on Bravo 400S (par 10.6).
 - Make sure that there are no allocated identification numbers: all Seletron devices must be displayed with the symbol , as shown in Fig. 224.
- If that is not the case, you must reset all allocated identification numbers. Use the function Identification numbers reset (par. 10.1.13).**

Fig. 224

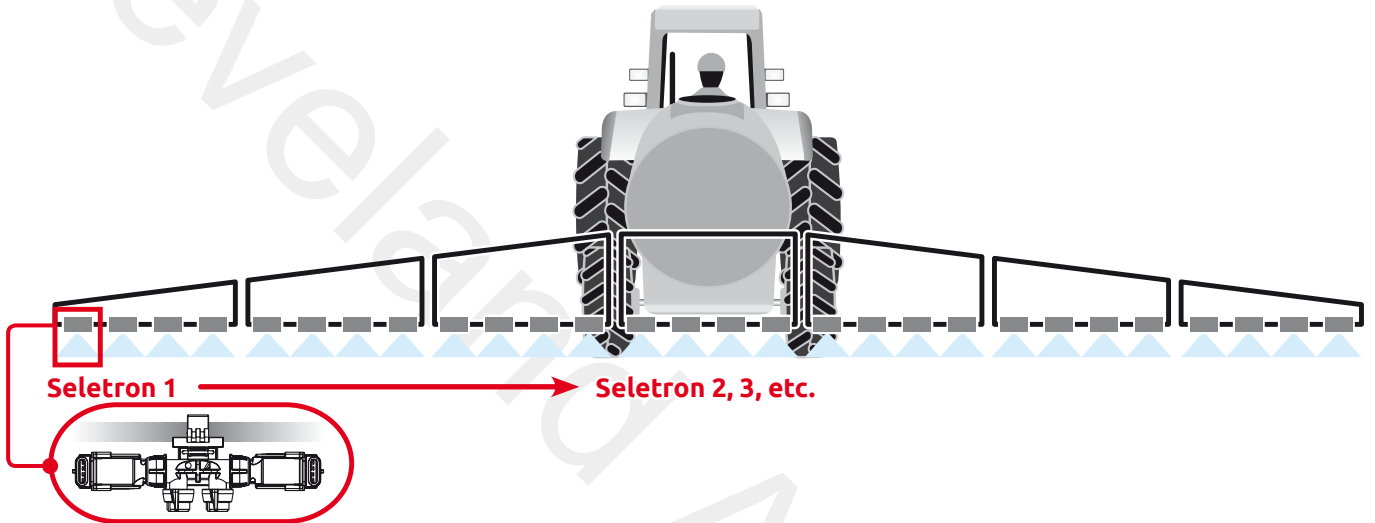


Fig. 225

- Connect the first Seletron device and wait for the acoustic signal from the cabin: **Seletron 1 is the one furthest to the left when looking at the machine from behind (Fig. 225).**
- Wait until you hear the acoustic signal, then connect the following Seletron device; continue to connect the remaining ones, from left to right until the end of the boom (waiting to hear the acoustic signal before each one).

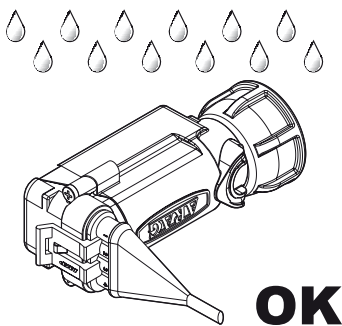
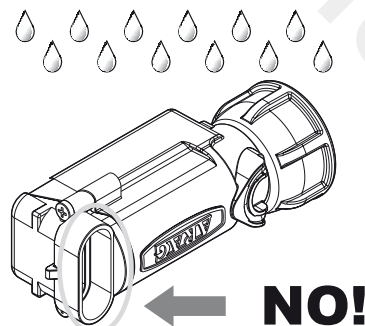


Fig. 226



The products are supplied with valve installation instructions. Make sure the device is correctly fitted and push it until locking it. When the cable is inserted in the connector, the Seletron is sealed. To avoid damaging the internal components, make sure that when using or cleaning the system the connectors are not bare or inserted incorrectly.

CONTINUES >>>

CONNECTION SEQUENCE FOR SINGLE AND TWIN SELETRON DEVICES

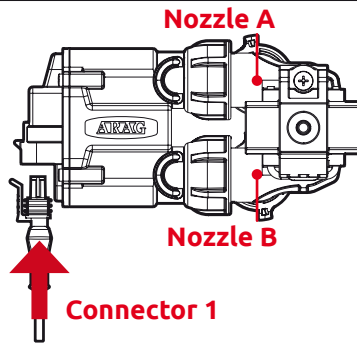


Fig. 227

Connect all Seletron devices in sequence, from left to right until the end of the boom.

CONNECTION SEQUENCE FOR FOURFOLD SELETRON DEVICES

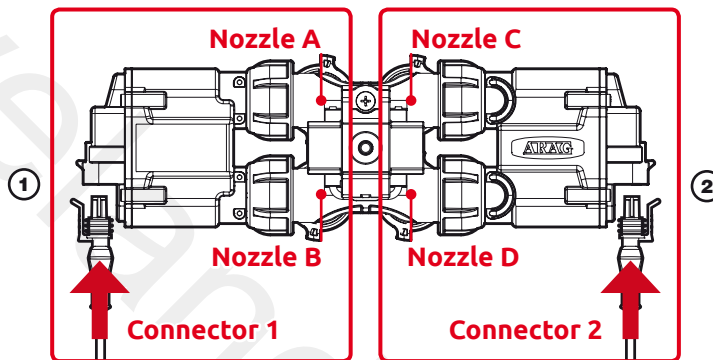


Fig. 228

- 1 Connect in sequence **ONLY SELETRON NOZZLE HOLDERS A AND B**, from left to right until the end of the boom (**connector 1** in Fig. 228).
- 2 Start again from the beginning: this time connect **SELETRON NOZZLE HOLDERS C AND D**, from left to right until the end of the boom (**connector 2**).

CONNECTION ERRORS

- The acoustic signal from the cabin is not emitted: check the status of the last connected Seletron device on the display (Fig. 224). If the corresponding Seletron is represented with the symbol or , reset all identification numbers and repeat the procedure from the beginning (par. 10.1.13, **Identification numbers reset**).
- If the problem persists on the same Seletron, replace it before repeating the procedure.

12 USE

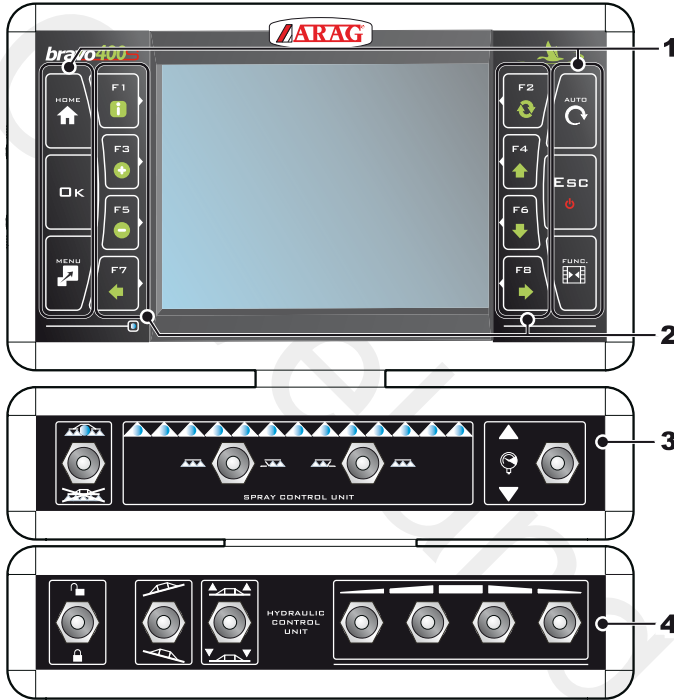


WARNING:

When Bravo 400S is configured as a GPS GUIDANCE MONITOR (chap. 9) it does not control the valves: any intervention must be made separately. For valve control see the relevant instruction manual.

The opening / closing of sections must be notified to Bravo 400S with the dedicated switches (par. 12.2) to provide information on the activity in the field manually. In this way, Bravo 400S will collect data on the job.

12.1 Controls on computer



Legend:

- 1** Control and display mode keys
- 2** Function keys.
Function keys are contextual: the function of each depends on what appears on the display, therefore **the use of these keys will be illustrated during the description of the corresponding procedures.**
- 3** Operating switches for control unit valves
- 4** Operating switches for oil-hydraulic functions (hydraulic valves)

Fig. 229

12.2 Operating switches for control unit valves



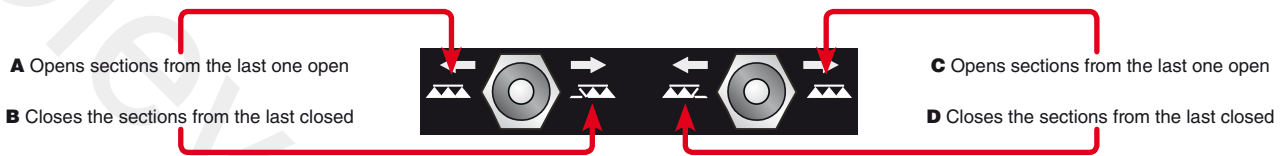
WARNING

When Bravo 400S is configured as a GPS GUIDANCE MONITOR (chap. 9) the switches signal the status of each section but do not control them: any intervention on the valves must be made separately, by consulting the instruction manual of the relevant control.

Communicating what happens on the field, Bravo 400S will collect data on the job.

Main control ON	Main control OFF	Section operating switches Open section Closed section		Output increase	Output decrease

• Switches for sequential control



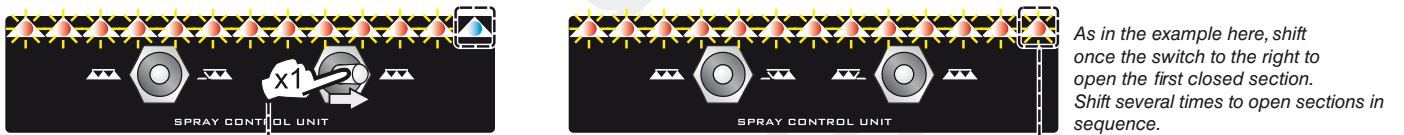
The valves can be opened and closed from the right to the left and vice versa with the section control switches. Prolonged pressure opens / closes the sections of half boom.

Examples:

• Closing of one section



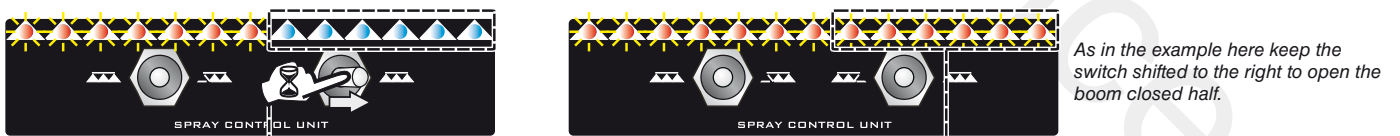
• Opening of one section



• Simultaneous closing of half boom sections



• Simultaneous opening of half boom sections



12.3 Operating switches for hydraulic valves

Boom release	Boom lock	Boom clockwise leveling	Boom counter-clockwise leveling	Increase boom height	Decrease boom height	Boom section movement: opening	Boom section movement: closing

12.4 Guidance screen

 When Bravo 400S is configured as a GPS GUIDANCE MONITOR (chap. 9) the display shows a limited amount of information.

USING THE KEYS



Fig. 230

F1 ÷ FB: Contextual function keys

These keys control what is shown on the display (display zoom adjustment, etc., Fig. 230)

When the function list is displayed, they perform specific functions: the function of each key depends on what appears on the display, therefore the use of these keys will be illustrated during the description of the corresponding procedures.

DISPLAY ITEMS

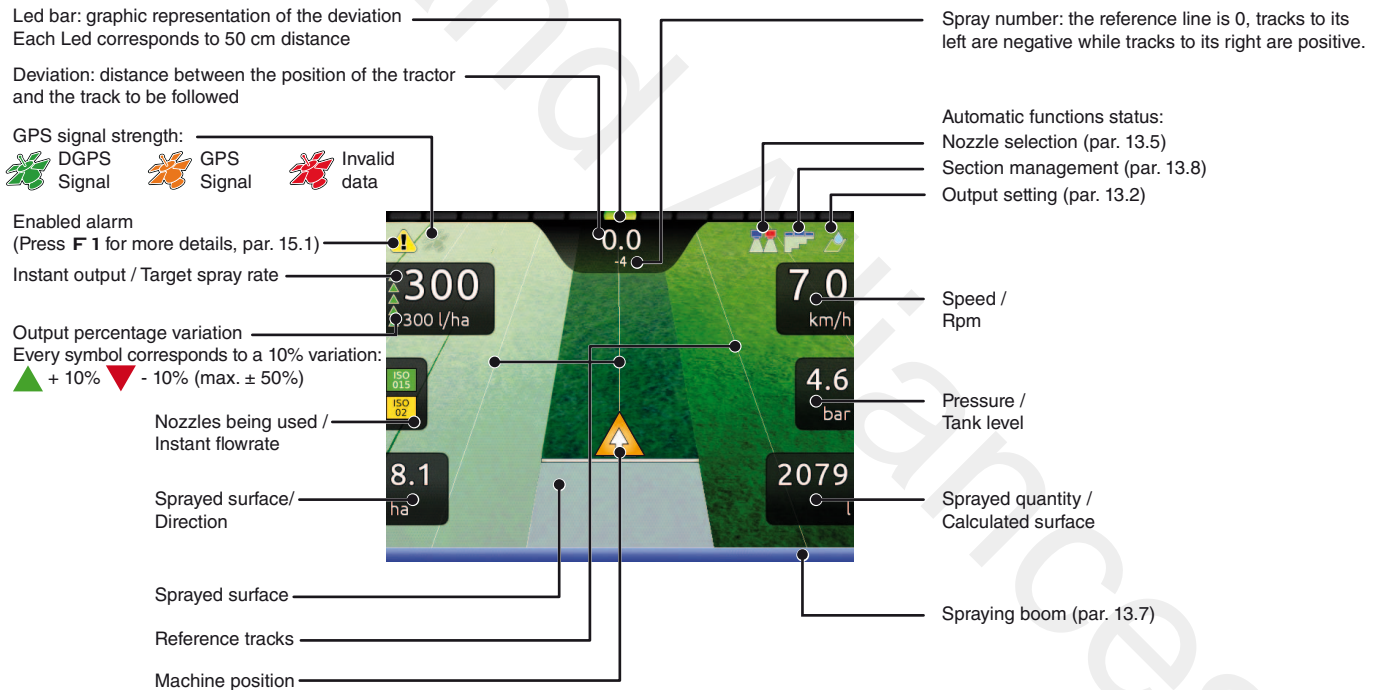


Fig. 231

12.5 Spraying a field

Let us assume we want to spray a field along parallel lines, but only once the edges of the field have been sprayed.

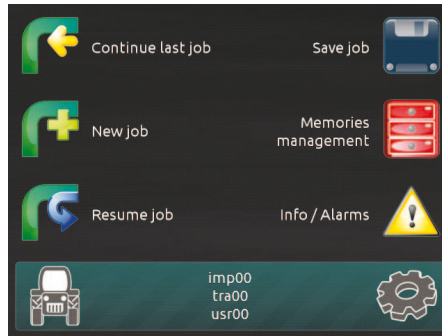


Fig. 232

- Go to the beginning of the field to be sprayed.
- Switch Bravo 400S on (par 7.2). After self-diagnostics, Bravo 400S displays the "Home" screen (Fig. 232).
- Begin a new job, using the function **F3 New job** (par. 14.3).
- Enter spraying settings.

When Bravo 400S is configured as a GPS GUIDANCE MONITOR (chap. 9) the settings are limited to starting the spraying.

SPRAYING SETTINGS

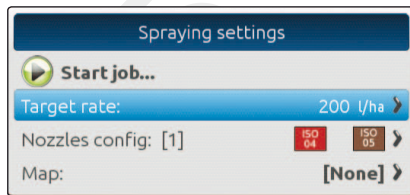


Fig. 233



Target rate

- Set the spray rate value for the treatment (Fig. 234). Press **OK** to confirm the value.

Fig. 234

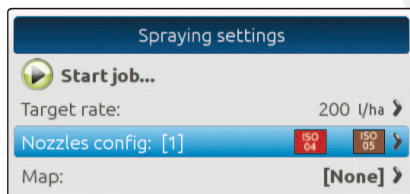


Fig. 235

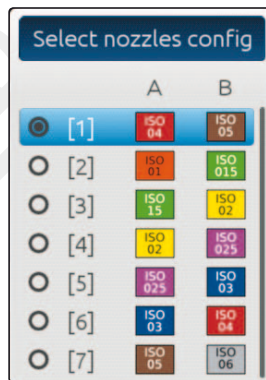


Fig. 236

Select nozzles config.

- Select a nozzle configuration from the list (Fig. 236). With this data indicate which nozzles are installed on the boom spraying points (preset configurations in the menu **Spray spots configurations**, par. 10.1.1).
- Press **OK** to confirm.

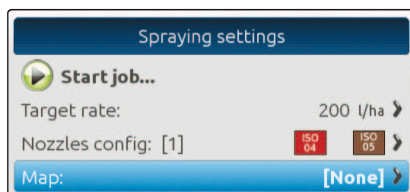


Fig. 237



Fig. 238

Map

- If there is at least one map (on the internal memory), you can select a prescription map for the spraying. According to the position detected by the GPS receiver, Bravo 400S will use the appropriate spray rate for the area that is being sprayed (par. 13.3 Importing and using a prescription map).
- Select a map from the list (Fig. 238).
- Press **OK** to confirm.

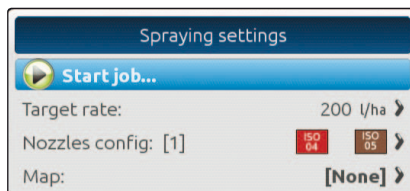


Fig. 239

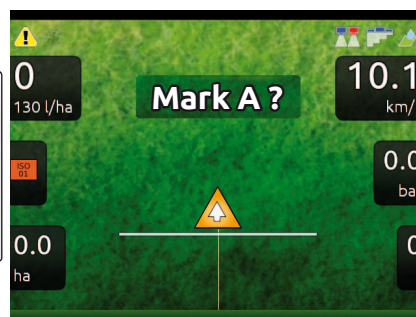


Fig. 240

Start job

- Select and press **OK** to switch to guidance.

CONTINUES



Fig. 241

- In the job menu, set the tank level with the function **F3 Tank** (par. 15.3).
- Start spraying by acting on the main control valve switch.
- Start moving along the field perimeter.

MARKING POINTS A AND B

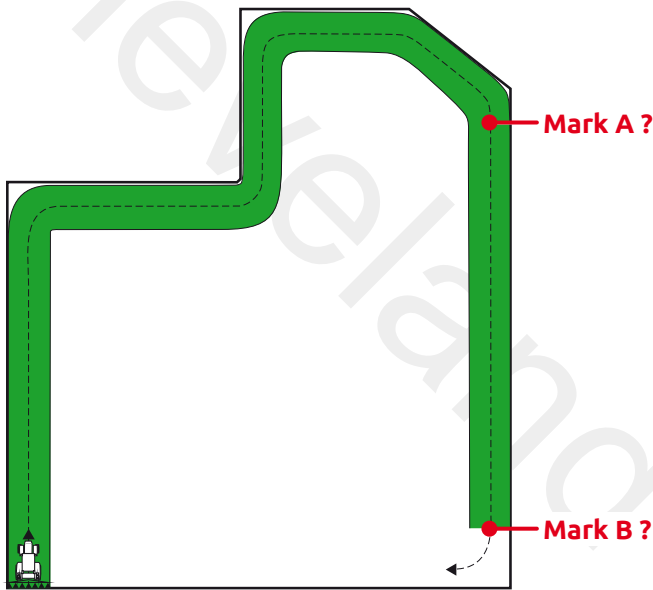



Fig. 242

- While moving along the perimeter of the field, you will mark points A and B (as described in par. 16.7 **F7 New AB**).

This operation is fundamental for Bravo 400S to guide you, during spraying, along tracks parallel to the reference track obtained by marking points A and B.

 **We recommend marking points A and B while the machine is moving, at both ends of a straight line that is as long as possible: the longer the line marked by points A and B, the lower the error caused by any deviations of the machine itself.**

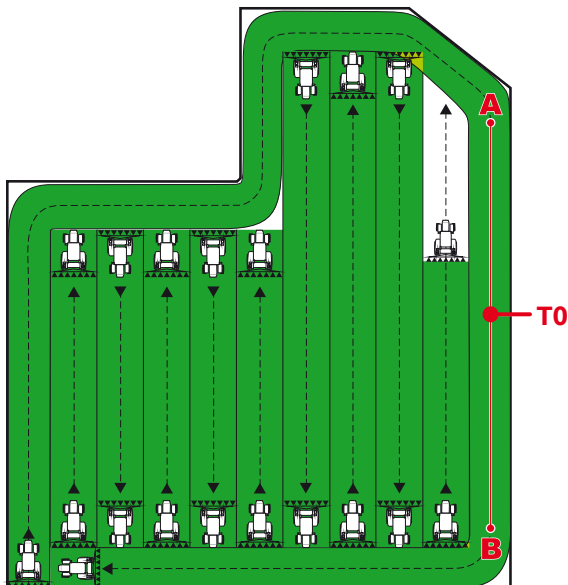



Fig. 243

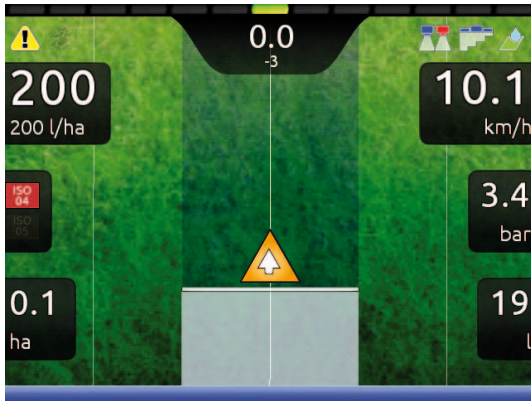
- Once the line from A to B has been marked (**T0**), it will be possible to spray the rest of the field along parallel lines, (Fig. 243), by following the reference tracks shown on the display (Fig. 244).



Fig. 244

 **At the beginning of a new job Bravo 400S gives driving directions in the "Straight parallel" mode. To change guidance mode see function **F2 Guidance mode** (par. 16.2).**

13 AUTOMATIC FUNCTIONS



To access automatic functions, start a job (**New job, Resume job, Continue last job**, chap. 14 "Home" Menu); in the guidance screen press **AUTO**. When the list is active (Fig. 245), pressing any key at the side will enable the relevant function.

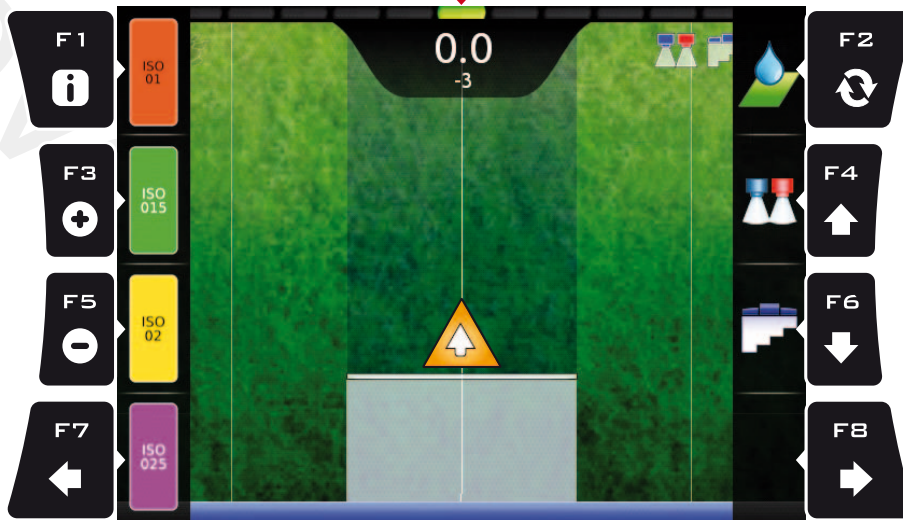











Fig. 245

The table below lists all available job functions and the corresponding function keys:

 Par.		 Par.	
13.6			Manual selection of NOZZLE A
13.6			Manual selection of NOZZLE B
13.6			Manual selection of NOZZLE C
13.6			Manual selection of NOZZLE D
		13.2	 ON/OFF automatic adjustment
		13.5	 Automatic nozzle selection ON / OFF
		13.8	 Automatic section management ON / OFF

13.1 Output adjustment

Bravo 400S can control chemical output with an automatic adjustment function (par. 13.2, *DEFAULT: ON*).

AUTOMATIC ADJUSTMENT ON



Bravo 400S keeps the set spray rate constant regardless from the changes in speed and boom section status.

In this case the spray rate can be set with the function **F1 Spray rate** (par. 16.1), or by uploading a prescription map (par. 13.3) from one of the external memories (SD card or pendrive).

If necessary, during spraying, it is possible to intervene on the dedicated switch (par. 12.2) to adjust output to crop conditions, increasing or decreasing momentarily the application rate up to $\pm 50\%$.



AUTOMATIC ADJUSTMENT OFF (MANUAL)



Rate manual regulation shall be carried out with the suitable switch (par. 12.2).



13.2 F2 Automatic adjustment ON/OFF

Enables / disables automatic output adjustment (*DEFAULT: ON*).



- 1 In the guidance screen, press **AUTO**.
- 2 Press **F2** (Fig. 246) to enable or disable automatic adjustment.

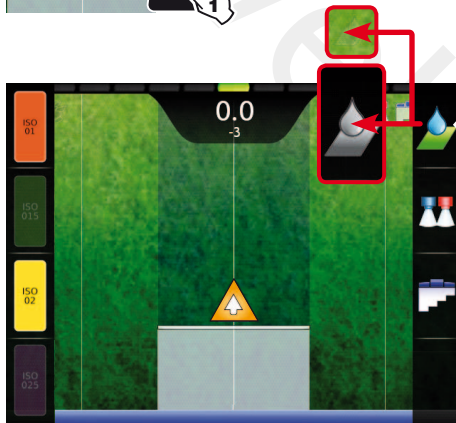
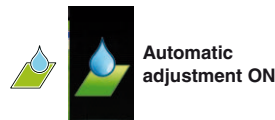


Fig. 246



13.3 Importing and using a prescription map

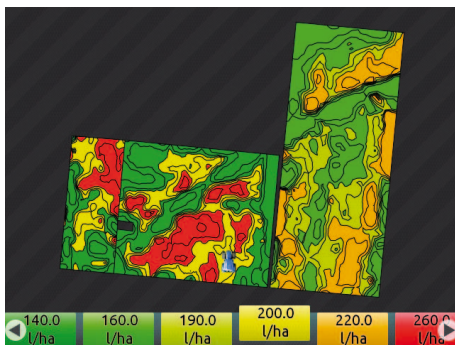


Fig. 247

Bravo 400S can vary output by using the data contained in a "prescription map", which indicates the exact quantity of fluid that must be sprayed at every point in the field.

The map is created thanks to a special analysis and simulation software. The correct spray rate is established for every point on the map, in order to obtain the optimal yield from a field with the minimum expenditure in terms of materials and time.

To enable Bravo 400S to read and use the collected information, the following is required:

- The prescription map must be in "Shapefile ESRI®" format.
- The database field containing the indication of the spray rate that must be applied to the different areas must be named "Rate".
- The database may include other fields, provided that these contain exclusively numerical values (the presence of any alphabetic characters will prevent the database from being imported correctly).

ESRI® is a registered trademark of ESRI, California, USA

At this point you must transfer the prescription map from one of the external memories (SD card or pendrive) onto Bravo 400S:

- Save the map on one of the external memories.
- Copy the map onto the internal memory, through the menu **Maps > Copy to internal memory** (from SD card par. 14.4.2, or pendrive par. 14.4.3).
- Select one of the functions in the "Home" menu: **F1 Continue last job** (par. 14.1), **F3 New job** (par. 14.3) or **F5 Resume job** (par. 14.5).
- In the job start screen select the desired prescription map.
- Proceed with the job. According to the position detected by the GPS receiver, Bravo 400S will use the appropriate spray rate for the area that is being sprayed (Fig. 247).

If the tractor is on a "black" area on the map, i.e., without a spray rate indication, Bravo 400S stops spraying.

13.4 How the automatic nozzle selection works (SELETRON system)

In a traditional system, the farming machine speed limits depend on the minimum and maximum pressure of the nozzle in use and on the desired spray rate.

For instance, if we were spraying 100 l/ha with a violet evenfan nozzle ISO110025, the minimum operating speed shall be 6.9 km/h (corresponding to a pressure of 1 bar) while maximum speed shall be 13.9 Km/h (corresponding to a pressure of 4 bars).

This operation field can be restrictive for the features of both crop to be treated and machine.

Operation field of possible combinations of ISO11002 and ISO110025 nozzles

When automatic nozzle selection is enabled, Bravo 400S (using Seletron devices) will enable the nozzle, or combination of nozzles, according to the set spray rate and driving speed.

This system allows to widen the machine operating range, i.e. in the above instance, using ISO11002 yellow (A) and ISO110025 violet (B) nozzles, that work correctly at a speed from 5.5 km/h to 24.9 km/h.

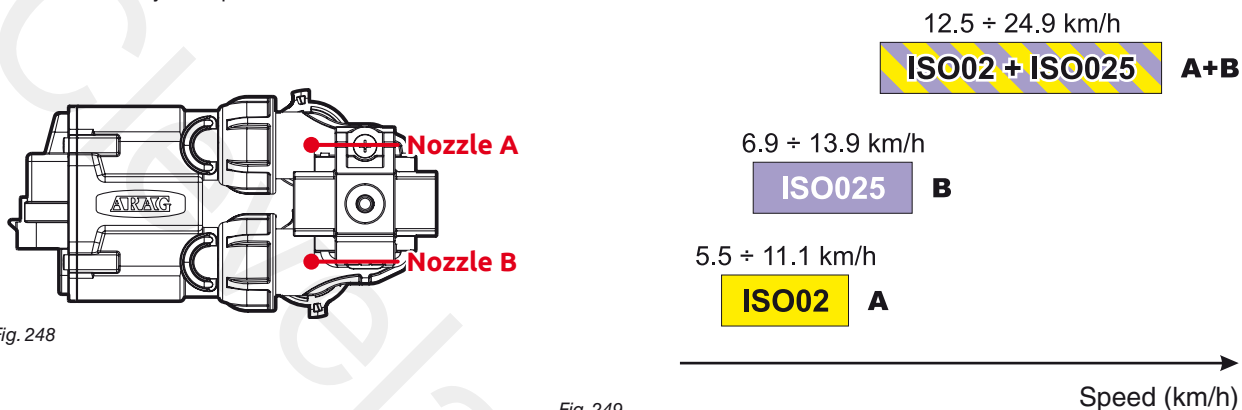


Fig. 248

Fig. 249

According to the set data and those detected by the sensors, Bravo 400S selects the suitable nozzle configuration constantly checking that:

- the spraying pressure always remains within the job features set for each single nozzle;
- in case of many possible nozzle configurations, the operating pressure of the configuration in use is as close as possible to the operating range of the nozzle;
- required number of nozzle changes is as low as possible.

When setting a treatment, make sure to couple compatible nozzles.

For example:

- **Compatible nozzles:** the rate at 1 bar of the ISO025 nozzle is LOWER than the rate at 5 bars of the ISO02 nozzle (Fig. 250).
- **NON compatible nozzles:** the rate at 1 bar of the ISO05 nozzle is HIGHER than the rate at 5 bars of the ISO02 nozzle (Fig. 251).

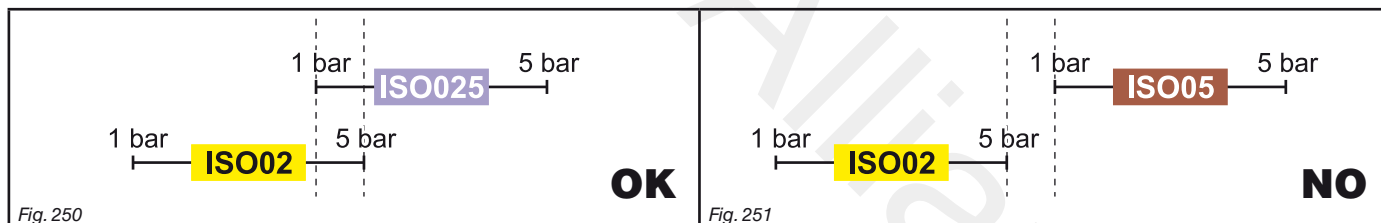


Fig. 250

Fig. 251

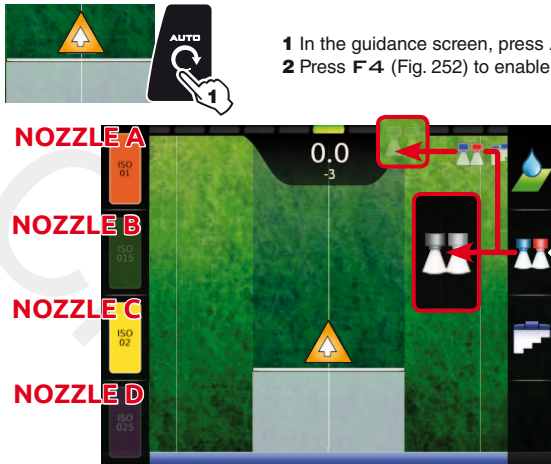
In the same way, the overall rate of both nozzles at MINIMUM pressure shall be LOWER than the rate of the high rate nozzle at MAXIMUM pressure.

When setting the treatment (par.12.5) Bravo 400S automatically checks the rates and in case the above conditions are not respected, the computer will display the message Wrong nozzles configuration!



13.5 F4 Automatic nozzle selection ON/OFF

Enables / disables automatic nozzle selection on all spraying points (DEFAULT: ON).



- 1 In the guidance screen, press **AUTO**.
- 2 Press **F4** (Fig. 252) to enable or disable automatic selection.



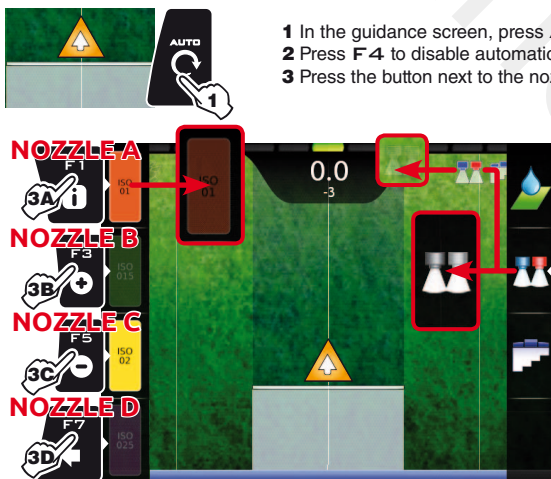
The number of nozzles displayed in (par. 10.1.1) will vary according to the spraying point setting Fig. 252.

Fig. 252

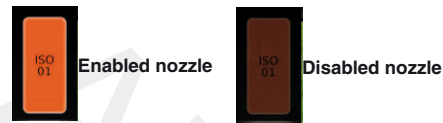


13.6 F1/F3/F5/F7 Manual nozzle selection

Allows to select manually nozzles A, B, C, D in use on the spraying points. This function is enabled ONLY when automatic nozzle selection is disabled (par. 13.5).

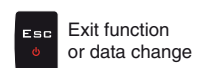
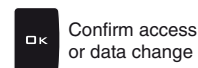


- 1 In the guidance screen, press **AUTO**.
- 2 Press **F4** to disable automatic nozzle selection (par. 13.5 F4 Automatic nozzle selection ON/OFF).
- 3 Press the button next to the nozzle (Fig. 253) to enable or disable the corresponding nozzle.



The number of nozzles displayed in par. 10.1.1 will vary according to the spraying point setting Fig. 253.


Fig. 253



13.7 Boom section management


 When Bravo 400S is configured as a GPS GUIDANCE MONITOR (chap. 9) section management is always MANUAL.

AUTOMATIC MANAGEMENT ON

 The section valves are closed or opened automatically.

 To change section valve management mode, use function **F6 Automatic section management ON/OFF** (par. 13.8).

AUTOMATIC MANAGEMENT OFF (MANUAL)

 Section valves must be opened or closed manually.

TREATMENT AND BOOM SECTION STATUS


 Main control
OFF

 Section
ON

 Zone to be sprayed
OPEN SECTION

 Zone already sprayed
CLOSE SECTION

OPENING AND CLOSING SIGNALS

 **MANUAL SECTION MANAGEMENT**

When overlapping is above the set value for the **Sections overlapping limit** (par. 10.1.12 / 10.2.2), Bravo 400S warns that the relevant sections must be CLOSED (Fig. 254). Close the section valve with the relevant switch: Bravo 400S will confirm closure on the display. As the machine advances, the signal is triggered for each section.

When overlapping returns within acceptable levels, Bravo 400S signals that the relevant sections can be OPENED (Fig. 255). Open the section valve with the relevant switch: Bravo 400S will confirm opening on the display. As the machine advances, the signal is triggered for each section.

Closing signal



Fig. 254

Opening signal



Fig. 255

 **AUTOMATIC SECTION MANAGEMENT**

When overlapping of ONE or ALL boom sections is above the set value for the **Sections overlapping limit** (par. 10.1.12 / 10.2.2), Bravo 400S CLOSES the relevant sections (Fig. 256). It is not necessary to intervene on the switches. Bravo 400S closes the sections automatically. Job interruption is shown on the display in real time.

When overlapping returns within the set limit, Bravo 400S opens the relevant sections automatically. Job resumption is shown on the display in real time (Fig. 257).

Automatic section closing



Fig. 256

Automatic section opening

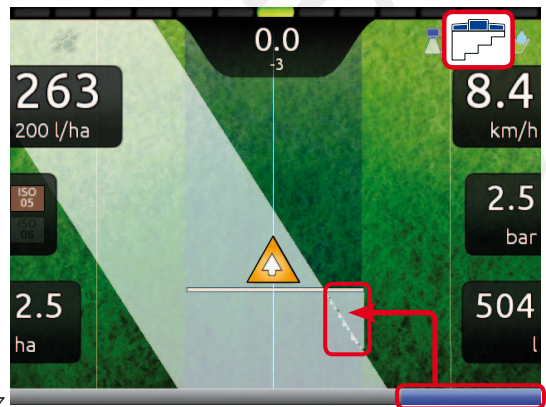


Fig. 257



13.8 F6 Automatic section management ON/OFF

Enables / disables automatic boom section management (DEFAULT: ON).



- 1 In the guidance screen, press **AUTO**.
- 2 Press **F6** (Fig. 258) to enable or disable automatic management.

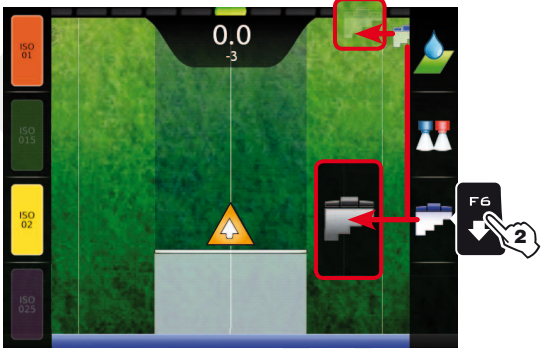
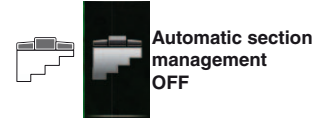
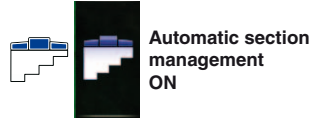


Fig. 258



eland Alliances

F1 Enter selected character

F2 Delete selected character

F7 **F8** Scroll (LEFT / RIGHT)

F4 **F6** Scroll (UP / DOWN) | Value Increase / decrease

OK Confirm access or data change

ESC Exit function or data change

14 "HOME" MENU

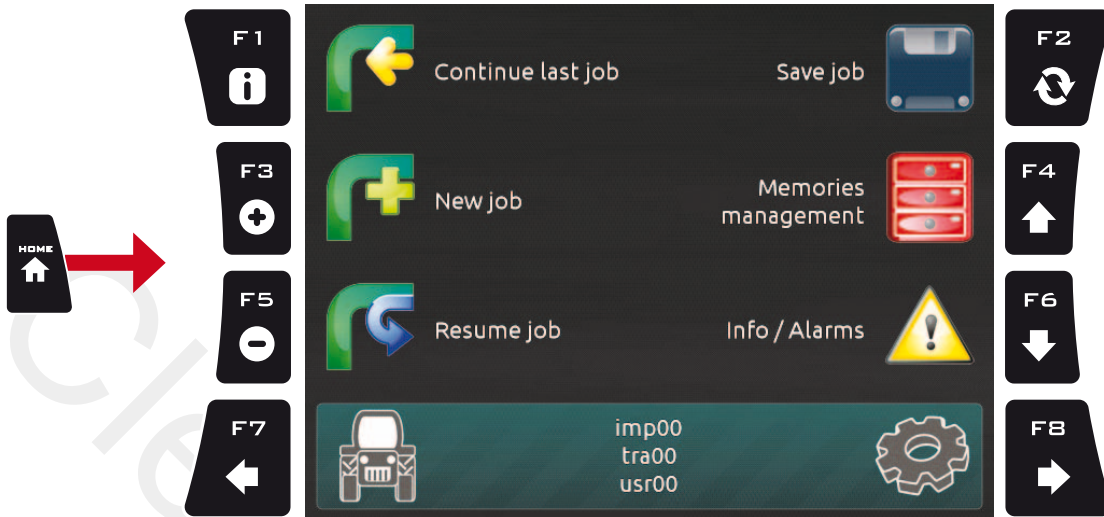










Fig. 259

To enter the menu press the **HOME** key: once inside the menu, pressing each key will enable the corresponding function. The table below sums up all menu items and corresponding keys:

Par.	
14.1	 Continue last job Continues last job
14.3	 New job Starts a new job
14.5	 Resume job Enables procedure for resuming a job
10	 Settings Selects / Creates settings for User, Tractor and Implement

Par.	
14.2	 Save job Saves current job
14.4	 Memories management Manages and copies data between internal and external memories (SD card, Pendrive)
14.6	 Info / Alarms Job information / alarms
10	 Settings Edits settings for User, Tractor and Implement



14.1 F1 Continue last job

Continues last job.


- 1 Press **F1** to continue the last job, from the point where it has been interrupted.
- 2 Check **Spraying settings** (**Target rate, Nozzles config, Map** in Fig. 261); change them if necessary.
- 3 Select  and press **OK** to switch to guidance mode.
- 4 Complete the job (Fig. 262).



Fig. 260

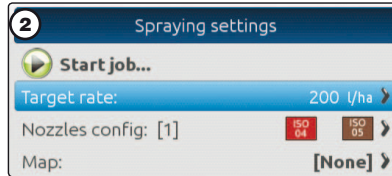


Fig. 261

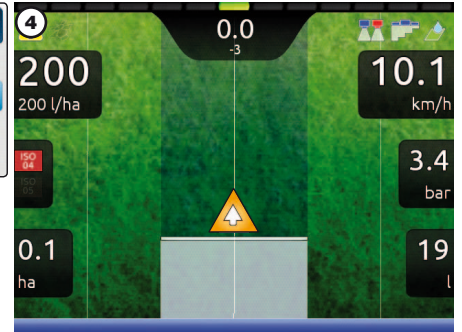


Fig. 262

- When the last job is resumed, Bravo 400S provides guidance information by restoring the conditions which were active at the time of interruption:
- Guidance mode
 - Marking points A and B
 - Marking points for surface calculation



Enter selected character



Delete selected character



Scroll (LEFT / RIGHT)



Scroll (UP / DOWN)

Value Increase / decrease



Confirm access or data change



Exit function or data change



Par. 74

14.2 F2 Save job Saves current job



Fig. 263

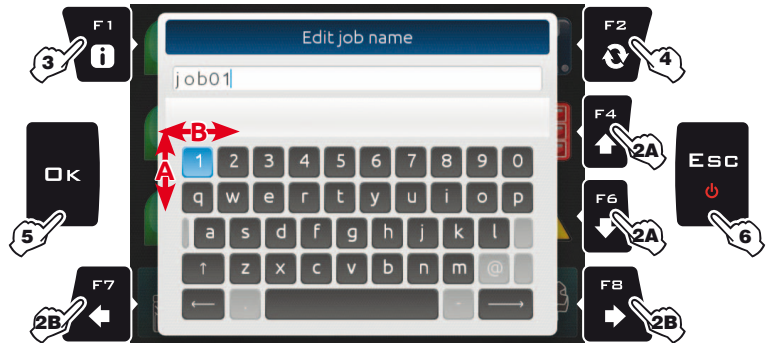


Fig. 264

- 1 Press **F2** to save current job: the name edit screen is displayed (Fig. 264). Type the name.
- 2A Press in succession to select the character you wish to type (UP / DOWN)
- 2B Press in succession to select the character you wish to type (RIGHT / LEFT).
- 3 Press to confirm the selected character.
- 4 Press to delete the character before the cursor.
- 5 Press to save the name
- 6 Press to exit screen without confirming modification

Legend:

job_01 |

Typed Name Cursor

9 Selected character

← → Shift cursor across name characters

↑ Caps lock



Fig. 265

A confirmation message is displayed once the process is completed (Fig. 265). Press **ESC**.



14.3 F3 New job

Starts a new job

1 Press **F3** to start a new job. Bravo 400S asks to save the current job (Fig. 266). Press **OK** to continue without saving (**2A**) or **ESC** to interrupt the procedure and save (**2B**).



Fig. 266

! IF AT THIS STAGE YOU CHOOSE TO CONTINUE WITHOUT SAVING (2A), ALL CURRENT JOB DATA WILL BE LOST.



2B The **ESC** key stops the beginning of a new job. **3B** Save the previous job with the function **Save job** (par. 14.2). Now start from point **1** to begin a new job.



Fig. 267

2A The **OK** key allows switching to the treatment start page without saving the job.

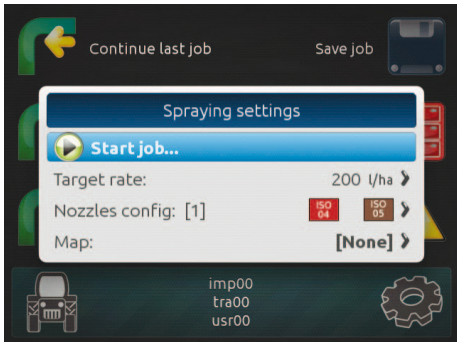


Fig. 268

Check **Spraying settings** (**Target rate, Nozzles config, Map** in Fig. 268); change them if necessary.

CONTINUES



14.4 F4 Memories management

Manages and copies data between internal and external memories (SD card, Pendrive)

Allows to upload, save and/or delete the data memorized on Bravo 400S or on an external memory (SD card / Pendrive); said data concern jobs carried out, maps or machine configurations. The operations that can be carried out will be illustrated in the following paragraphs.

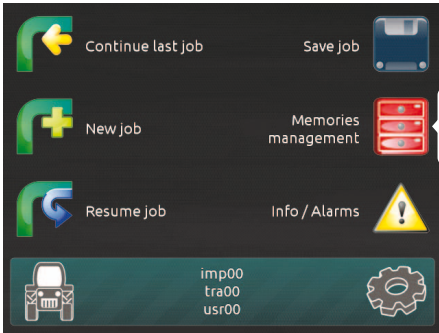


Fig. 269

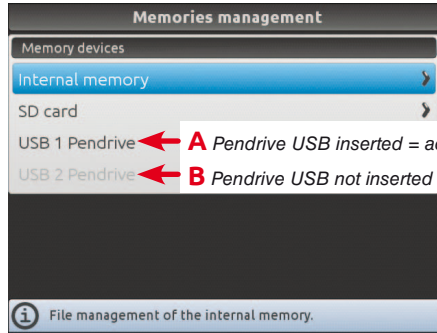


Fig. 270

CONTINUES

14.4.1 Internal memory

Allows to transfer the saved data concerning **Implements, Tractors, Users, Jobs** or **Maps**, from the internal memory of Bravo 400S onto an "external" support (SD card or USB pendrive).

The following paragraphs will use **Implements** as an example: the same procedure will be valid for all other cases (**Tractors, Users, etc.**, Fig. 272).



- 1 Press **F4** to enter **Memories management**.
- 2 Select the **Internal memory** menu and press **OK**.
- 3 Select **Implements** (Fig. 272) and press **OK**.
- 4 In the list of memorized names select the desired implement (Fig. 273) and press **OK**.

A list of actions that can be performed for the selected implement will appear (**Delete** etc., Fig. 273). These will be described below.

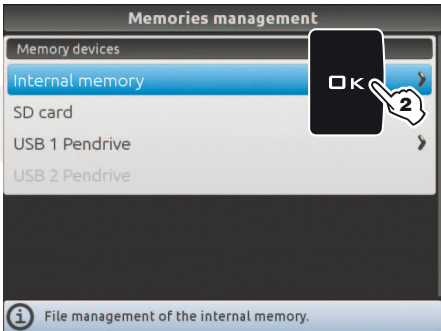


Fig. 271

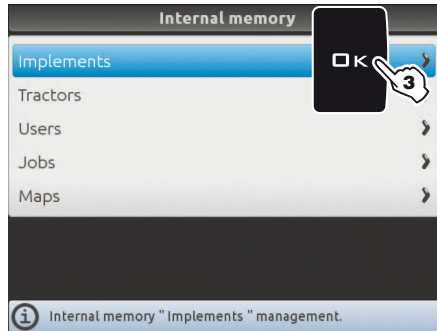
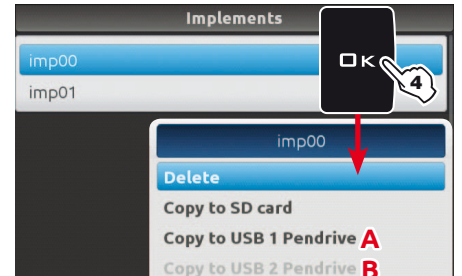


Fig. 272



A Pendrive USB inserted = active action
B Pendrive USB not inserted = locked action
 Fig. 273

• Delete

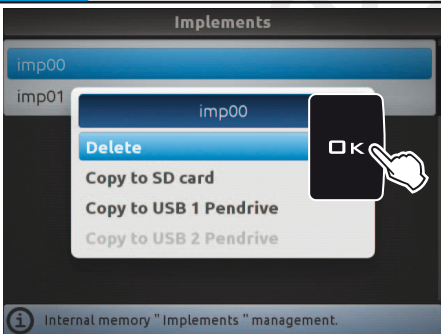


Fig. 274

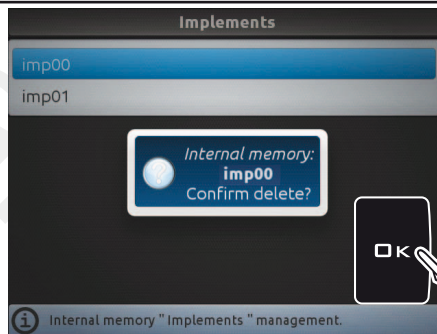


Fig. 275

Allows to delete data from Bravo 400S internal memory.
 - Select **Delete** (Fig. 274) and press **OK**.
 - The message in Fig. 275 is displayed: confirm deletion by pressing **OK** again.

• Copy to SD card

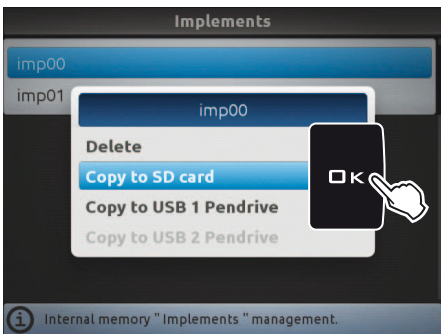


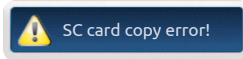
Fig. 276

Allows to copy data from Bravo 400S internal memory onto a SD card.
 - Select the item **Copy to SD card** (Fig. 276) and press **OK**;

ERROR MESSAGES



A file with the same name already exists on the SD card. You can do the following:
 - Press **OK** to replace the file.
WARNING: ALL data in the replaced file will be lost.
 - Press **ESC** to avoid replacing the file; check its contents or edit its name before trying to save again.



- There is no more space available on the SD card: delete a few files from the memory and try saving again (par. 14.4.2 - **SD card > Implements > Delete**).
 - The SD card is locked. Remove the protection and try saving again.

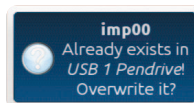
• Copy to USB Pendrive (1 or 2)



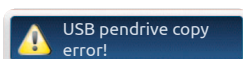
Fig. 277

Allows to copy data from Bravo 400S internal memory onto a pendrive.
 - Select the item **Copy to USB Pendrive** (Fig. 277) and press **OK**;

ERROR MESSAGES



A file with the same name already exists on the pendrive. You can do the following:
 - Press **OK** to replace the file.
WARNING: ALL data in the replaced file will be lost.
 - Press **ESC** to avoid replacing the file; check its contents or edit its name before trying to save again.



- There is no more space available on the pendrive. delete a few files from the memory and try saving again (par. 14.4.3 - **USB Pendrive > Implements > Delete**).
 - The pendrive is locked. Remove the protection and try saving again.

14.4.2 SD card

Allows to transfer the saved data concerning **Implements, Tractors, Users, Jobs** or **Maps**, from the SD card onto the internal memory of Bravo 400S. The following paragraphs will use **Implements** as an example: the same procedure will be valid for all other cases (**Tractors, Users, etc.**, Fig. 279).



- 1 Press **F4** to enter **Memories management**.
- 2 Select the **SD card** menu and press **OK**.
- 3 Select **Implements** (Fig. 279) and press **OK**.
- 4 In the list of memorized names select the desired implement (Fig. 280) and press **OK**.

A list of actions that can be performed for the selected implement will appear (**Delete** etc., Fig. 280). These will be described below.

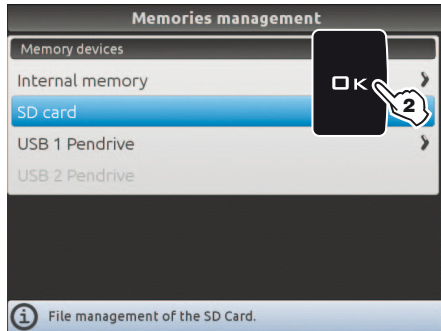


Fig. 278

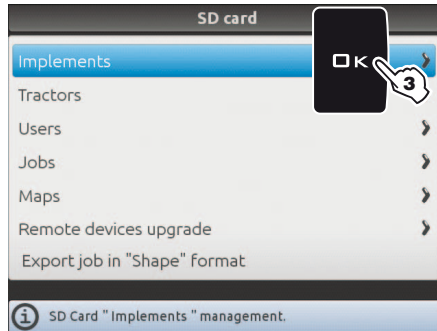


Fig. 279

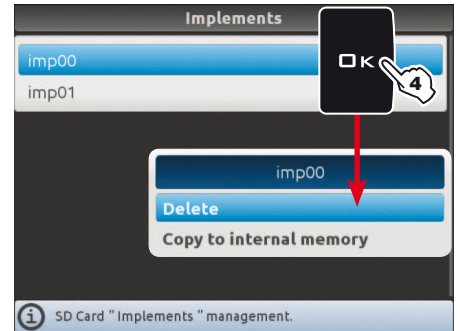


Fig. 280

• Delete

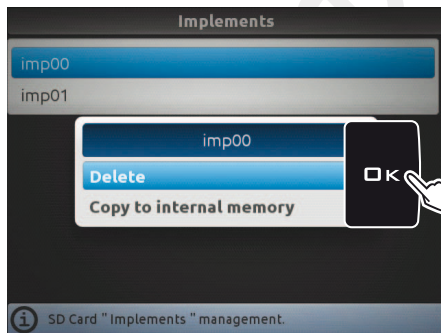


Fig. 281

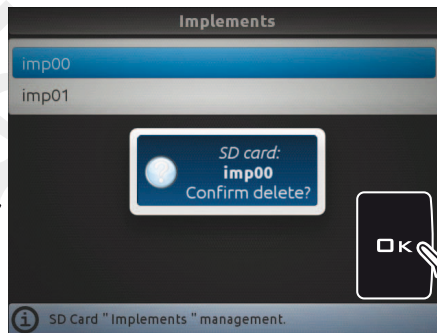


Fig. 282

Allows to delete data from the SD card.
 - Select **Delete** (Fig. 281) and press **OK**.
 - The message in Fig. 282 is displayed: confirm deletion by pressing **OK** again.

• Copy to internal memory

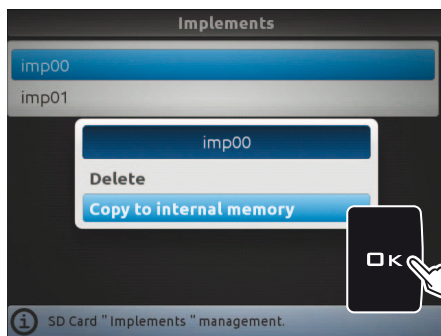


Fig. 283

Allows to copy data from the SD card onto Bravo 400S internal memory.
 - Select the item **Copy to internal memory** (Fig. 283) and press **OK**;

ERROR MESSAGES



Fig. 284

A file with the same name already exists on the internal memory. You can do the following:
 - Press **OK** to replace the file.
WARNING: ALL data in the replaced file will be lost.
 - Press **ESC** to avoid replacing the file; check its contents or edit its name before trying to save again.

CONTINUES

Remote devices upgrade

Allows to upgrade the software of the devices connected to Bravo 400S: Seletron RCU (control unit), hydraulic RCU, switch box, etc.

Before starting the procedure copy the upgrade files onto the SD card.

- Insert the SD card in a card reader and connect it to the computer. The window to the right will appear: select **Open folder to view the files.**
- The SD card explorer window will open: create a new folder and name it "s19"



Fig. 285

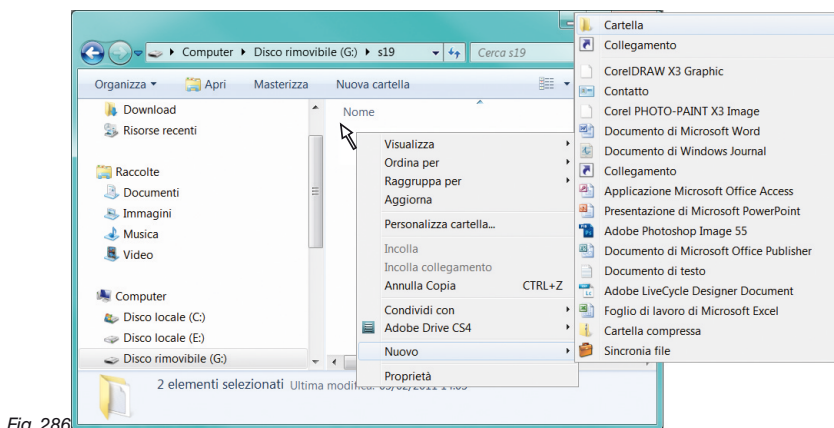


Fig. 286

- Select the upgrade file and drop it onto the SD card explorer window, in the folder named "s19".
- Insert the SD card in its slot on Bravo 400S.

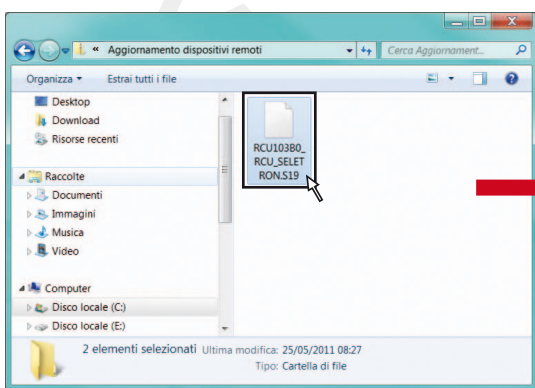
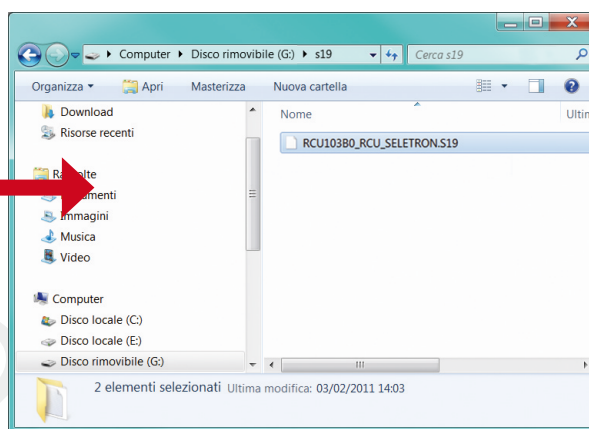


Fig. 287



CONTINUES

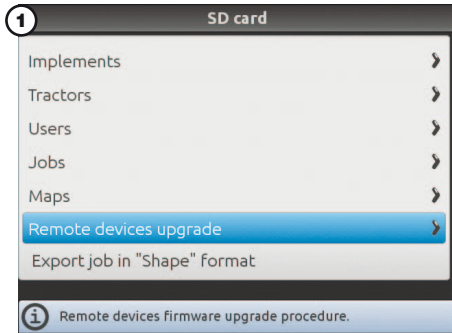


Fig. 288

1 Select the **Remote devices upgrade** menu and press **OK**.

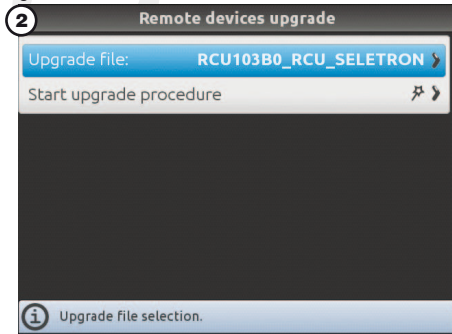


Fig. 289

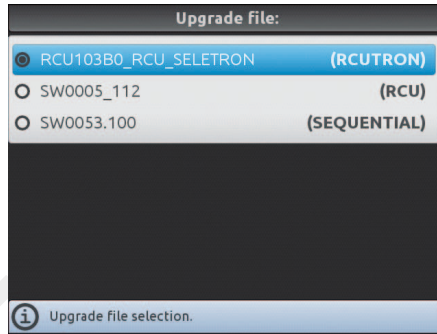


Fig. 290

2 Enter the **Upgrade file** menu, select the desired file from the list (Fig. 290) and press **OK**.

- Available upgrades:**
- **RCUTRON:**
Seletron RCU upgrade
 - **RCU:**
Hydraulic RCU upgrade
 - **SEQUENTIAL:**
sequential control switches upgrade

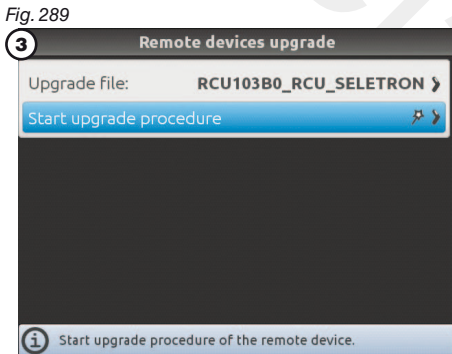


Fig. 291

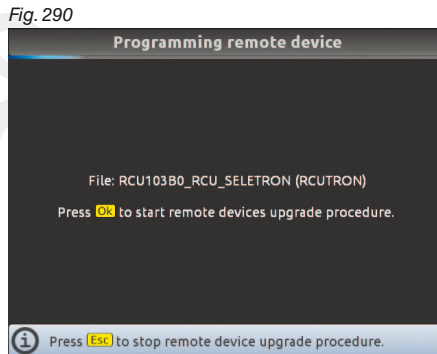


Fig. 292

3 Now select **Start upgrade procedure** and press **OK**. Follow the instructions on the display and start the setup procedure (Fig. 292).



Fig. 293

- When the message in Fig. 293 appears, the upgrade is complete. Press **OK**.

• **Export job in "Shape" format**

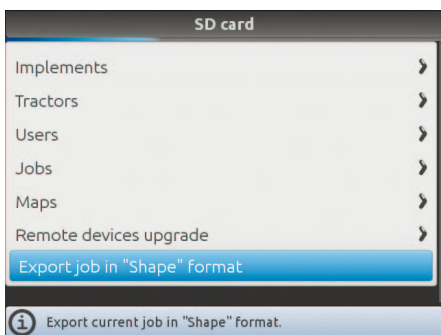


Fig. 294

Allows to memorize job data onto a map, saving it onto the SD card. Data in the file can be displayed on a Personal Computer with a "Shape" file viewer (.shp).

- Select **Export job in "Shape" format** (Fig. 294) and press **OK**.
- A confirmation message appears once the process is completed. Press **OK**.

14.4.3 USB Pendrive

Allows to transfer the saved data concerning **Implements, Tractors, Users, Jobs** or **Maps**, from the pendrive onto Bravo 400S internal memory. The following paragraphs will use **Implements** as an example: the same procedure will be valid for all other cases (**Tractors, Users, etc.**, Fig. 296).



- 1 Press **F4** to enter **Memories management**.
- 2 Select the **USB Pendrive** menu and press **OK**.
- 3 Select **Implements** (Fig. 296) and press **OK**.
- 4 In the list of memorized names select the desired implement (Fig. 297) and press **OK**.

A list of actions that can be performed for the selected implement will appear (**Delete** etc., Fig. 297). These will be described below.

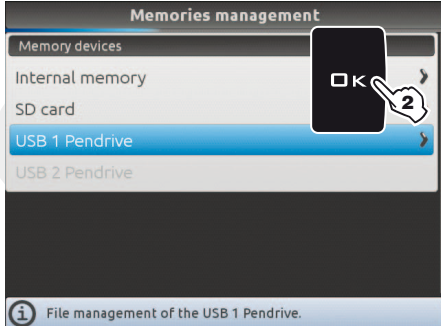


Fig. 295

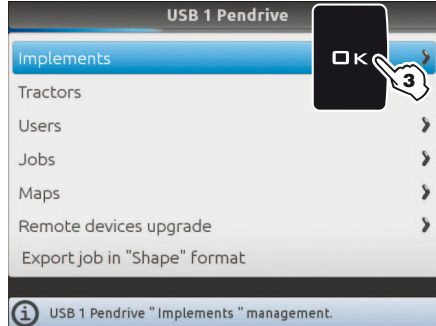


Fig. 296

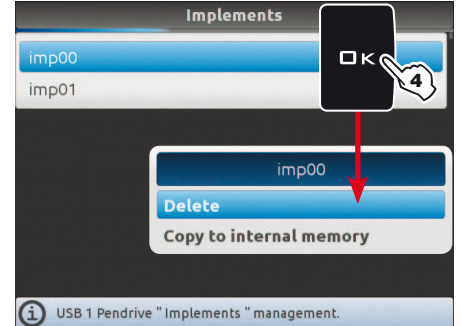


Fig. 297

Delete

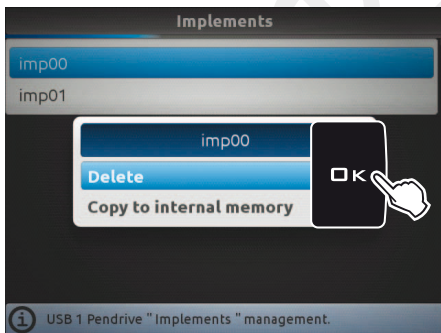


Fig. 298



Fig. 299

Allows to delete data from the pendrive.
 - Select **Delete** (Fig. 298) and press **OK**.
 - The message in Fig. 299 is displayed: confirm deletion by pressing **OK** again.

Copy to internal memory

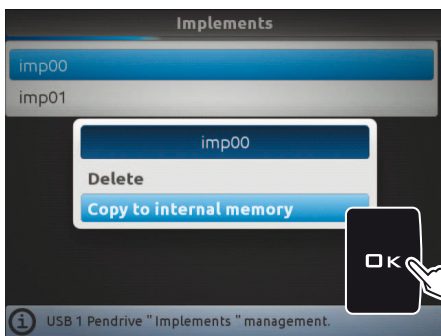


Fig. 300

Allows to copy data from the pendrive onto Bravo 400S internal memory.
 - Select the item **Copy to internal memory** (Fig. 300) and press **OK**;

ERROR MESSAGES



Fig. 301

A file with the same name already exists on the internal memory. You can do the following:
 - Press **OK** to replace the file.
WARNING: ALL data in the replaced file will be lost.
 - Press **ESC** to avoid replacing the file; check its contents or edit its name before trying to save again.

CONTINUES

• Remote devices upgrade

Allows to upgrade the software of the devices connected to Bravo 400S: Seletron RCU (control unit), hydraulic RCU, switch box, etc.

Before starting the procedure copy the upgrade files onto the pendrive.

- Insert the pendrive in a pendrive reader and connect it to the computer. The window to the right will appear: select **Open folder to view the files.**

- The pendrive explorer window will open: create a new folder and name it "s19"



Fig. 302

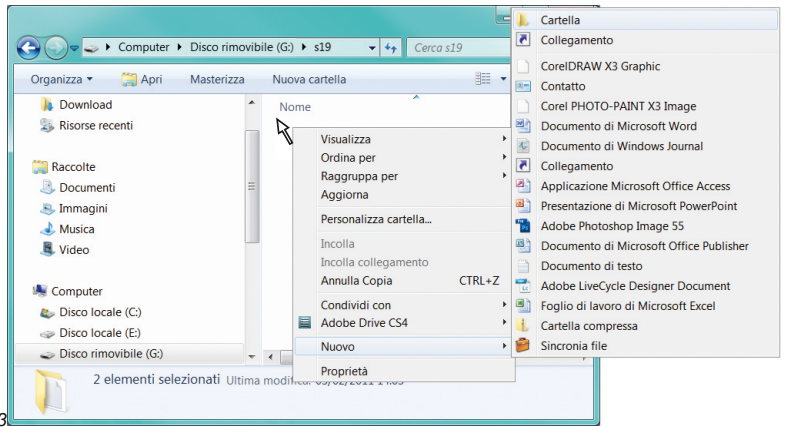


Fig. 303

- Select the upgrade file and drop it onto the pendrive explorer window, in the folder named "s19".
- Insert the SD card in its slot on Bravo 400S.

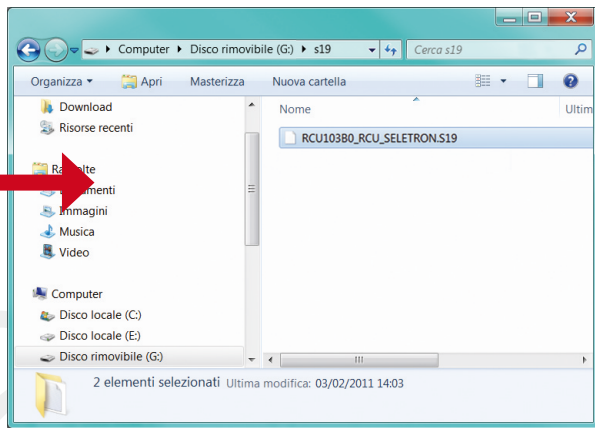
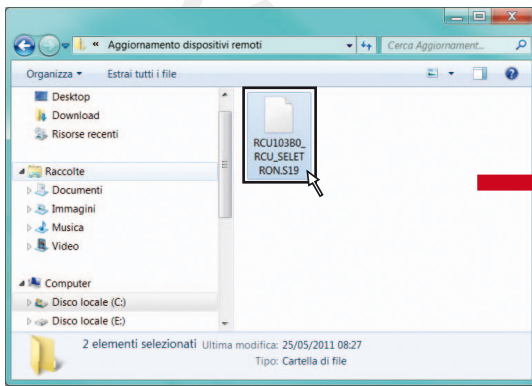
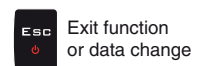
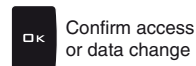


Fig. 304

Alliances

CONTINUES



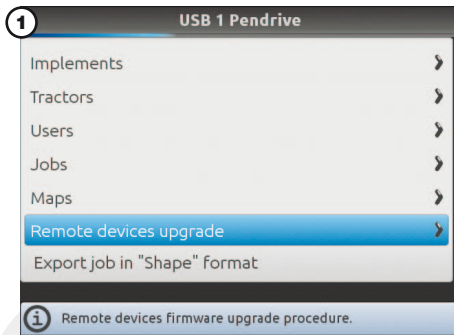


Fig. 305

1 Select the **Remote devices upgrade** menu and press **OK**.

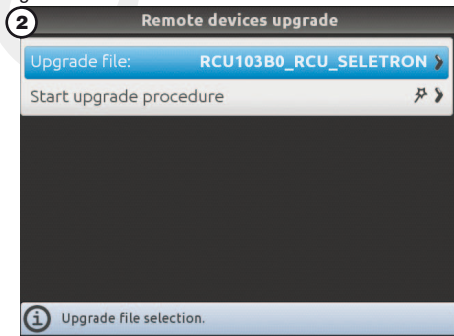


Fig. 306

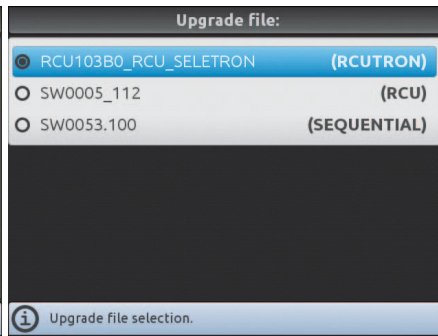


Fig. 307

2 Enter the **Upgrade file** menu, select the desired file from the list (Fig. 307) and press **OK**.

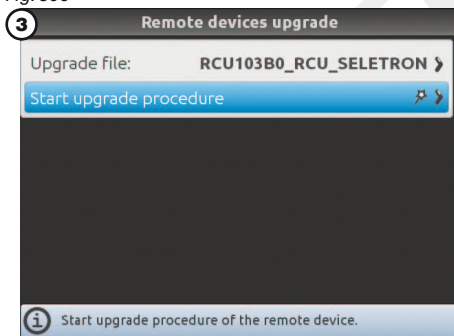


Fig. 308



Fig. 309

3 Now select **Start upgrade procedure** and press **OK**. Follow the instructions on the display and start the setup procedure (Fig. 309).



Fig. 310

4 When the message in Fig. 310 appears, the upgrade is complete. Press **OK**.

• Export job in "Shape" format

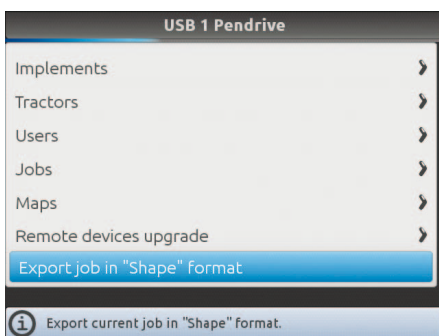



Fig. 311

Allows to memorize job data onto a map, saving it onto the pendrive. Data in the file can be displayed on a Personal Computer with a "Shape" file viewer (.shp).
 - Select **Export job in "Shape" format** (Fig. 311) and press **OK**.
 - A confirmation message appears once the process is completed. Press **OK**.



14.5 F5 Resume job

Enables procedure for resuming a previously interrupted job.

- 1 Press **F 1** to resume a previous job, from the list of saved jobs.
- 2 In the list, select the desired configuration (Fig. 312) and press **OK** to confirm.
- 3 Check **Spraying settings (Target rate, Nozzles config, Map** in Fig. 313); change them if necessary.
- 4 Select  and press **OK** to switch to guidance mode.
- 5 Complete the job (Fig. 314).

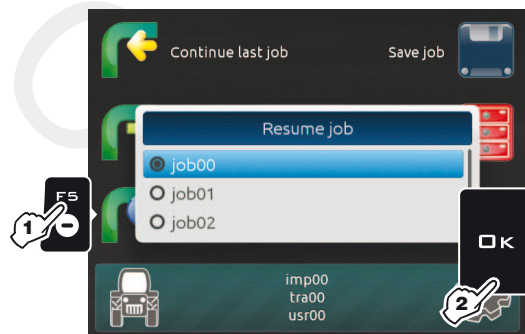


Fig. 312

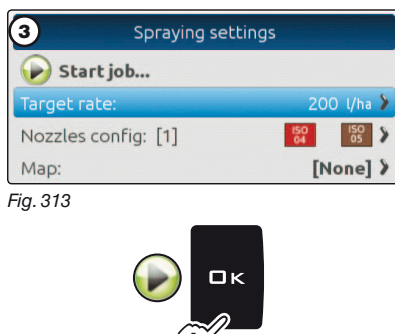


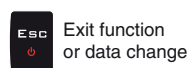
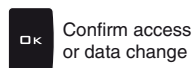
Fig. 313

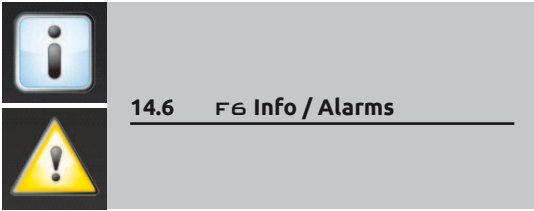


Fig. 314

When the last job is resumed, Bravo 400S provides guidance information by restoring the conditions which were active at the time of saving:

- Guidance mode
- Marking points A and B
- Marking points for surface calculation





Displays job information / alarms.



Fig. 315

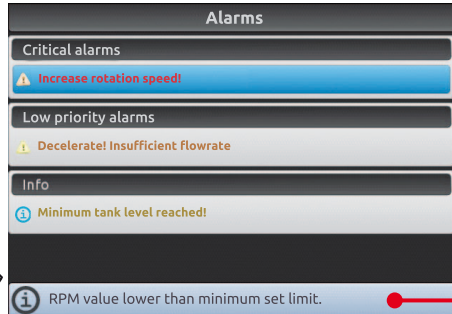


Fig. 316

1 Press **F6** to view the **Info / Alarms** menu (Fig. 316). This screen gives an overview of the active notifications for the operator, rated by importance as **Critical alarms**, **Low priority alarms** and **Info**.

A description of the selected notification is shown at the bottom of the display.

Meland Alliances

15 JOB MENU

When Bravo 400S is configured as a GPS GUIDANCE MONITOR (chap. 9) the menu contains a limited amount of items.



To access job menu start a job (**New job, Resume job, Continue last job**, chap. 14 "Home" Menu); in the guidance screen press **MENU**. In the job menu (Fig. 317), pressing any key at the side will enable the relevant function.

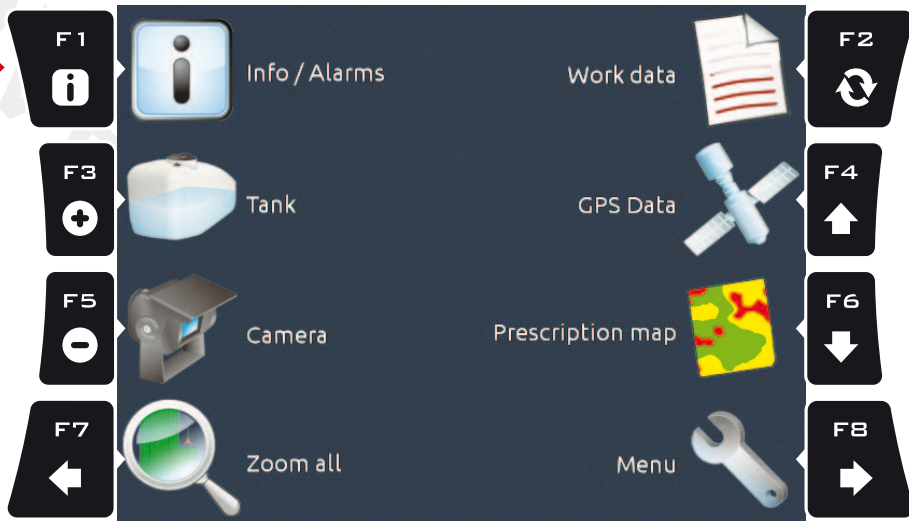
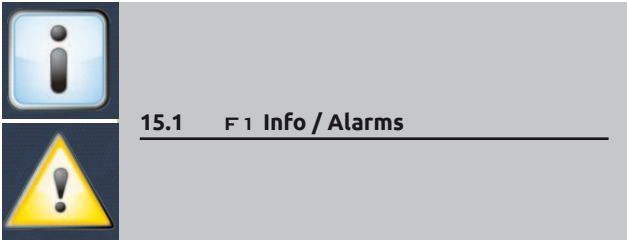


Fig. 317 The table sums up all menu items and corresponding keys:

Par.	Icon	Key	Function
15.1		F1	Info / Alarms
Displays job information / alarms			
15.2		F2	Work data
Displays job data			
15.3		F3	Tank
Tank filling management			
15.4		F4	GPS data
Displays GPS data			
15.5		F5	Camera
Displays images from connected cameras			
15.6		F6	Prescription map
Overview of the prescription map in use			
15.7		F7	Zoom all
Overview of the field during spraying			
15.8		F8	Menu
Job settings menu			

Enter selected character	Delete selected character	Scroll (LEFT / RIGHT)	Scroll (UP / DOWN)	Value Increase / decrease	Confirm access or data change	Exit function or data change	Par. 7.4
--------------------------	---------------------------	-----------------------	--------------------	---------------------------	-------------------------------	------------------------------	----------



Displays job information / alarms

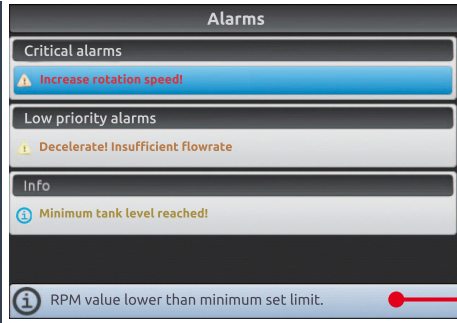


1 In the guidance screen, press **MENU**.



2 Press **F 1** to view the **Info / Alarms** menu (Fig. 319).

This screen gives an overview of the active notifications for the operator, rated by importance as **Critical alarms**, **Low priority alarms** and **Info**.



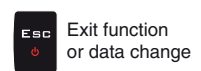
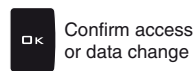
A description of the selected notification is shown at the bottom of the display.

Fig. 318

Fig. 319



Value Increase / decrease



15.2
F2 Work data

Displays job data



- 1 In the guidance screen, press **MENU**.
- 2 Press **F2** to view job data (Fig. 321 and Fig. 322).
- 3 Press **F4 / F6** to scroll data.

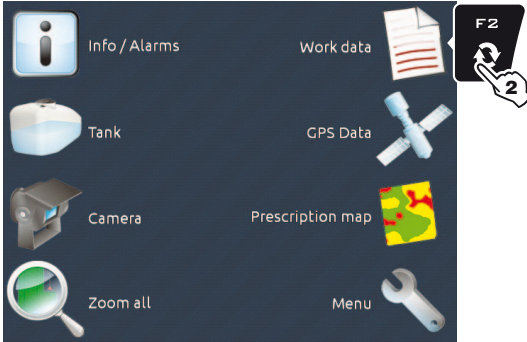


Fig. 320

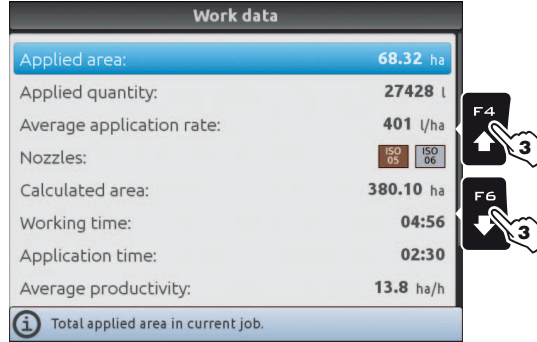


Fig. 321

The data and unit of measurement shown are listed in par. 18.1.

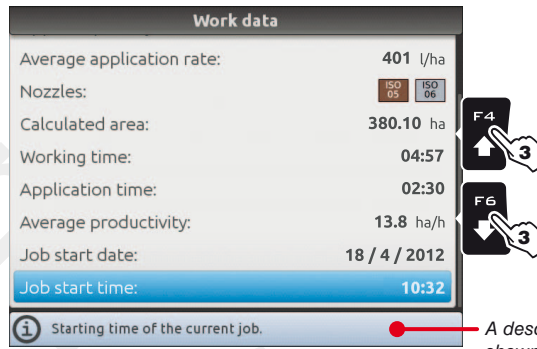


Fig. 322

A description of the selected data is shown at the bottom of the display.



15.3 F3 Tank

Manages tank filling.



- 1 In the guidance screen, press **MENU**.
- 2 Press **F3** to view the **Tank** menu (Fig. 324).

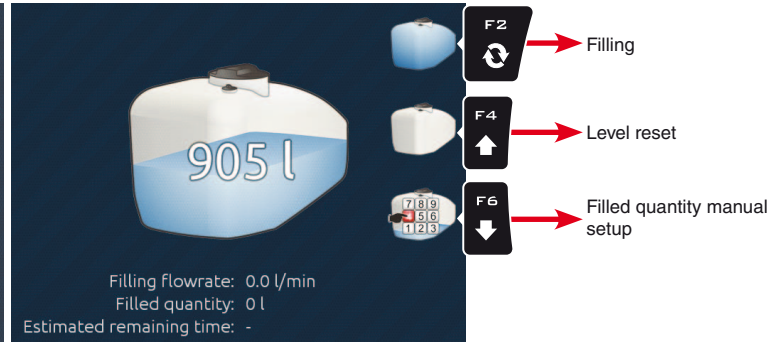
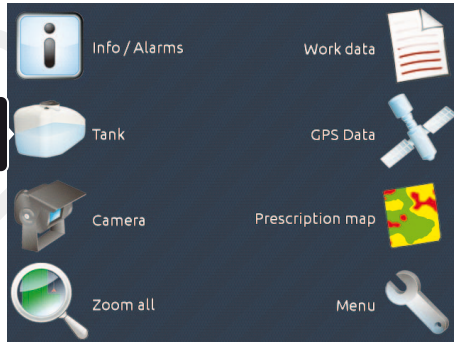


Fig. 323

Fig. 324

In this screen it is possible to enable several procedures:

- Filling (Fig. 325)
- Level reset (Fig. 326)
- Filled quantity manual setup (Fig. 327)

When the filling flowmeter is connected, the display shows the filling data in real time.

TANK FILLING

Fig. 325

Press **F2** to set tank level to the maximum value.
The display will show the tank as full: its total capacity has been set during advanced setup (par. 10.1.10).

LEVEL RESET

Fig. 326

Press **F4** to set tank level to zero.
The display will show the tank as empty.

FILLED QUANTITY MANUAL SETUP

Fig. 327

- Press **F6** to set the quantity of liquid filled in the tank.
- Set the value and confirm.

The display will show the tank level that has been reached.

It is not possible to set values higher than tank total capacity.

F1 Enter selected character

F2 Delete selected character

F7 **F8** Scroll (LEFT / RIGHT)

F4 **F6** Scroll (UP / DOWN)

Value Increase / decrease

OK Confirm access or data change

ESC Exit function or data change



15.4 F4 GPS Data

Displays GPS data



- 1** In the guidance screen, press **MENU**.
- 2** Press **F4** to view the **GPS Data** menu (Fig. 329). This screen shows the data sent to the GPS receiver.



Fig. 328

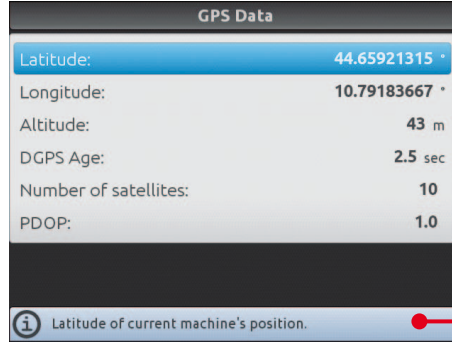
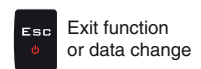
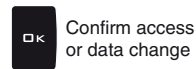
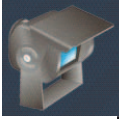


Fig. 329

A description of the selected data is shown at the bottom of the display.





15.5 F5 Camera

Displays images from connected cameras



1 In the guidance screen, press **MENU**.

2 Press **F5** to view the **Camera** menu (Fig. 331).

By connecting one or more cameras, it is possible to monitor working areas and at the same time view spraying data.

Enable camera view during advanced setup (par. 10.3.3).



Fig. 330



Fig. 331



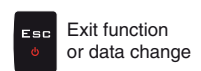
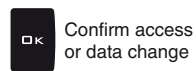
F2 Switch view between the two cameras

F7 Select job data displayed on the LEFT side of the screen.

F8 Select job data displayed on the RIGHT side of the screen.



Value Increase / decrease



15.6 F6 Prescription map

Overview of the prescription map in use



1 In the guidance screen, press **MENU**.

2 Press **F6** to view the **Prescription map** menu (Fig. 333).

From this screen it is possible to view data of the prescription map during spraying and to check the position of the machine on the map.

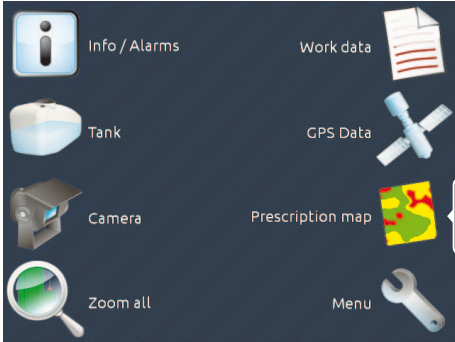


Fig. 332

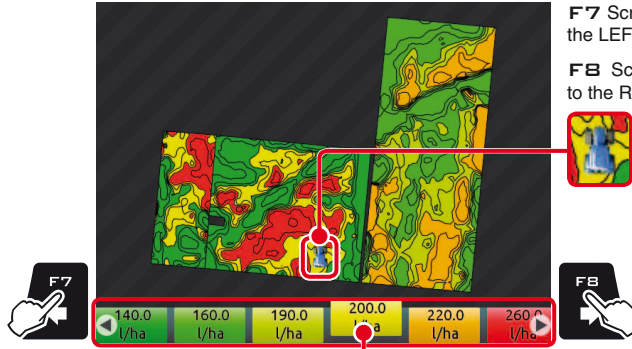


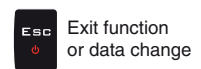
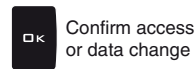
Fig. 333

F7 Scroll spray rate values to the LEFT.

F8 Scroll spray rate values to the RIGHT.

Machine position

Spray rate values legend:
The highlighted box displays the spray rate referred to the machine's current position





15.7 F7 Zoom all

Overview of the field during spraying



- 1 In the guidance screen, press **MENU**.
- 2 Press **F7** to view the **Zoom all** menu (Fig. 335).



Fig. 334

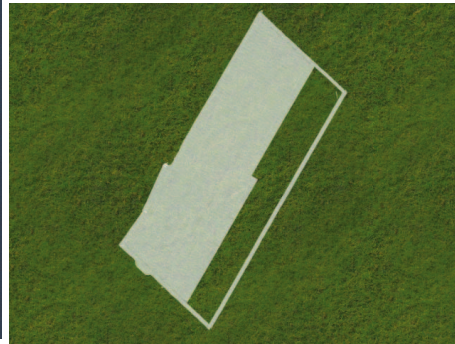
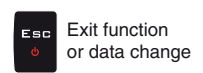
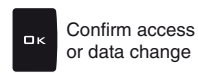


Fig. 335



Value Increase / decrease





15.8 F8 Menu

Job settings menu



- 1 In the guidance screen, press **MENU**.
- 2 Press **F8** to view the **Menu Settings** menu (Fig. 337).



Fig. 336

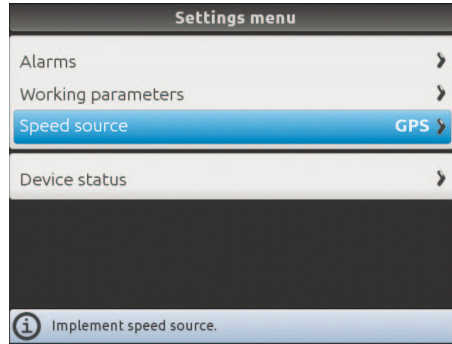


Fig. 337

In this screen it is possible to access several different menus, which can be useful during spraying:

- **Alarms** (par. 10.1.11).
- **Working parameters** (par. 10.1.12).
- **Device status** (par. 10.6).

15.8.1 Speed source

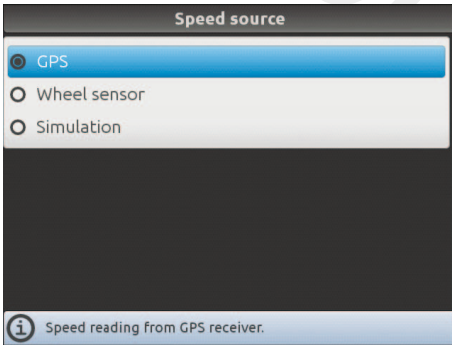


Fig. 338

Allows to select the source for speed calculation. Available options:

• **GPS**

Information concerning speed is received by the GPS, which is connected directly to Bravo 400S.

• **Wheel sensor**

When this option is enabled, the speed is calculated on the basis of the pulses received by the speed sensor installed on the wheel.

! WARNING: guidance information and all accessory functions (surface calculation, alignment, etc.) are disabled.

The wheel constant must be entered during the setup procedure (par. 10.1.8).

• **Simulation**

Allows to enable speed simulation in order to carry out adjustment tests even when the machine is stationary.

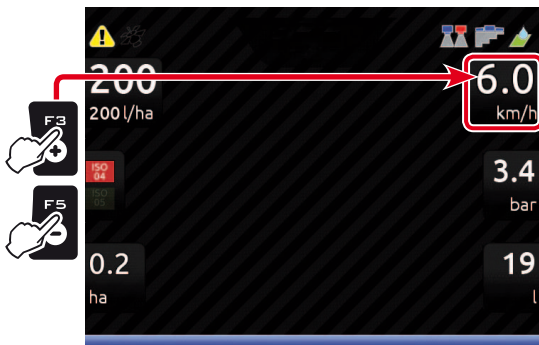
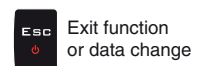
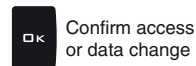


Fig. 339

SIMULATION SPEED

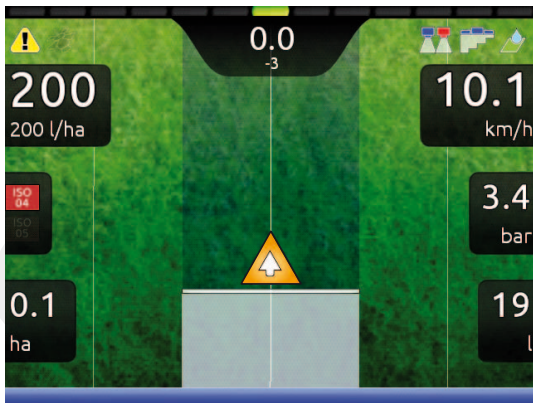
Edit simulation speed (DEF 6.0 km/h - 3.7 MPH):
F3 (+) increase, F5 (-) decrease

! WARNING: guidance information and all accessory functions (surface calculation, alignment, etc.) are disabled.



16 JOB FUNCTIONS

 When Bravo 400S is configured as a GPS GUIDANCE MONITOR (chap. 9) job functions are limited.



To access job functions start a job (**New job, Resume job, Continue last job**, chap. 14 "Home" Menu); in the guidance screen press **FUNC.** When the list is active (Fig. 340), pressing the key at the side will enable the relevant function.

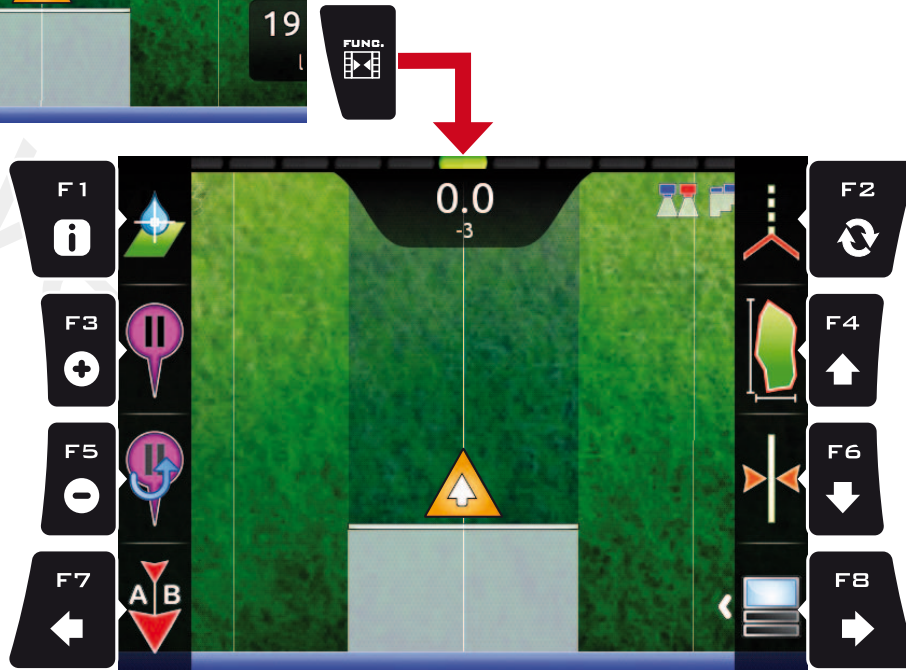














Fig. 340

The table below lists all available job functions and the corresponding function keys:

Par.	Icon	Description
16.1		Spray rate Change spray rate
16.3		Pause Save job breaking point
16.5		Resume from pause Guidance indications to return to job breaking point
16.7		New AB Create a new AB track

Par.	Icon	Description
16.2		Guidance mode Select guidance mode
16.4		Surface Calculate field surface
16.6		Align Align to nearest track
16.8		Display Display options Includes several functions:
		F2 Tractor themes
		F4 Spraying themes
		F6 Daytime/night time display mode
		F8 2D / 3D display mode

 Enter selected character	 Delete selected character	 Scroll (LEFT / RIGHT)	 Scroll (UP / DOWN)	 Value Increase / decrease	 Confirm access or data change	 Exit function or data change	 Par. 74
--	---	---	--	---	--	--	---

16.1 F 1 Spray rate Change spray rate



- 1 In the guidance screen, press **FUNC.**
- 2 Press **F 1** to enable the function.
- 3 Change the spray rate value for the job (Fig. 342).
- 4 Confirm the data.

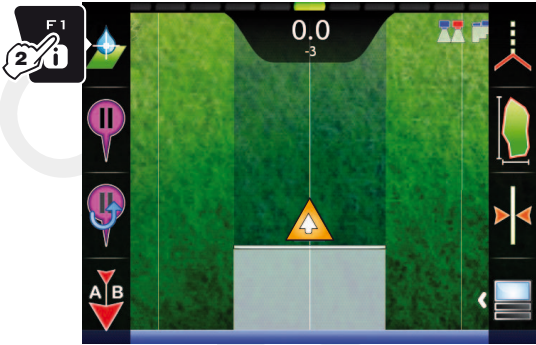
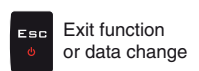
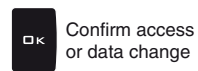


Fig. 341



Fig. 342



16.2 F2 Guidance mode

Selecting guidance mode



- 1 In the guidance screen, press **FUNC.**
- 2 Press **F2** to enable the function.
- 3 Select a guidance mode (Fig. 344): press **F4** and **F6** to move across the available items (**A - Straight guidance mode**, **B - Curved guidance mode** or **C - Free guidance mode**)
- 4 Confirm selection.

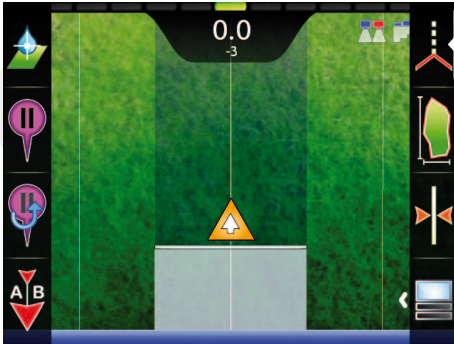


Fig. 343

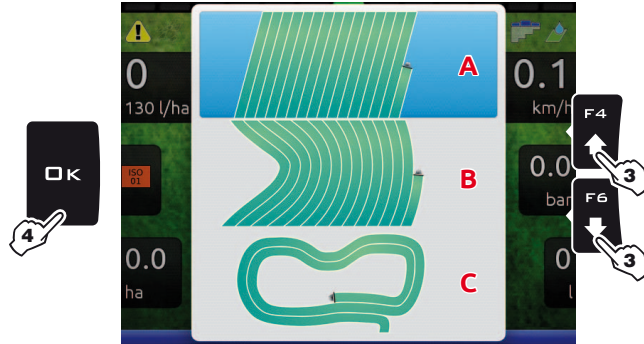


Fig. 344

A - STRAIGHT GUIDANCE MODE

Fig. 345

The tracks appearing on the display, which will act as a guidance reference, are perfectly straight and parallel to the reference line joining point A to point B as previously marked. Any bends in the trajectory between **A** and **B** will be ignored.

B - CURVED GUIDANCE MODE

Fig. 346

The tracks appearing on the display, which will act as a guidance reference, include portions that are not straight, but do not include sharp bends (Fig. 348). The trajectory between **A** and **B** will be saved and Bravo 400S will create evenly distributed tracks.

Fig. 348

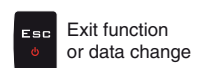
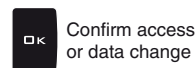
C - FREE GUIDANCE MODE

Fig. 347

No guidance references are shown on the display. The operator will drive freely and will be able to check the spraying range on the display in real time.




Value Increase / decrease




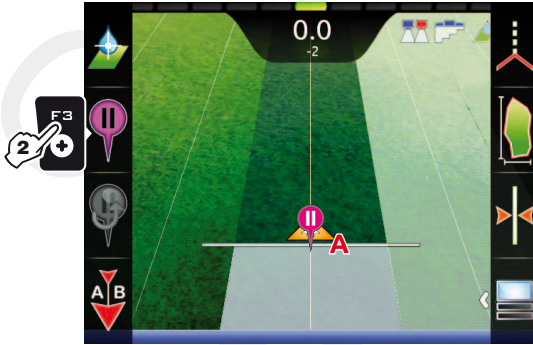


16.3 F3 Pause

Saves job breaking point, which will be shown on the display with the symbol .



- 1 In the guidance screen, press **FUNC**.
- 2 Press **F3** when you are in the position you wish to save (**A** in Fig. 349):
The symbol  will be placed exactly on that point.




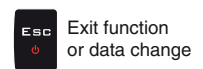
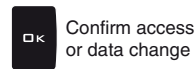
 **Bravo 400S can save ONLY ONE BREAKING POINT:**
every time you save a point, the previous one will be deleted.

Fig. 349

ealand Alliances



16.4 F4 Surface

Enables the procedure to calculate field surface by driving along its perimeter.

- 1 In the guidance screen, press **FUNC.**
- 2 Press **F4** to start the surface calculation procedure (function list disappears). The following message will appear: **Field edge side selection** prompting the operator to select which side of the machine to use as a reference to define the field perimeter.
- 3 Press **F3** (Left) or **F4** (Right): a white line will be displayed to draw the field perimeter as the tractor moves (Fig. 351).



Fig. 350

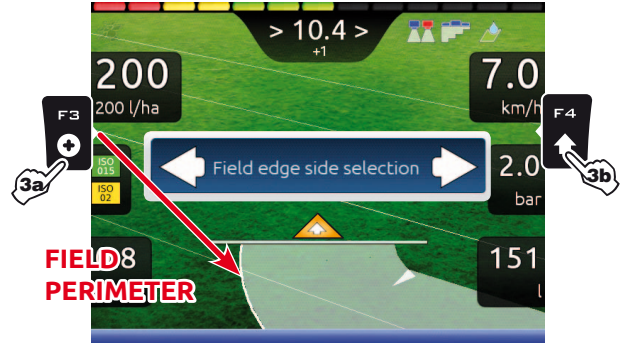


Fig. 351

- 4 Drive along the perimeter of the field or of the surface you wish to measure. When you get close to the calculation starting point, press **FUNC** again.
- 5 Press **F4** to complete the surface calculation procedure (Fig. 352). The computer will connect starting and end points and will calculate the surface.
- 6 To view **Calculated area**, press **MENU** followed by **F2** (access to the **Work data** screen, par. 15.2).



Fig. 352

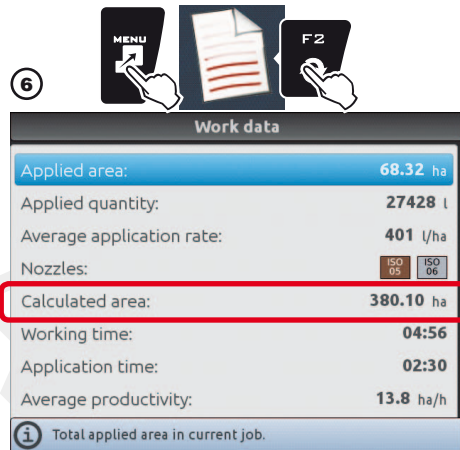


Fig. 353

FIELD PERIMETER ON MACHINE LEFT-HAND SIDE

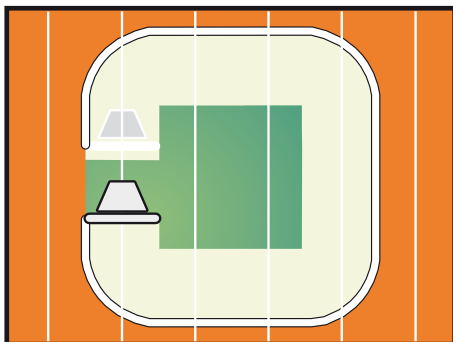


Fig. 354

FIELD PERIMETER ON MACHINE RIGHT-HAND SIDE

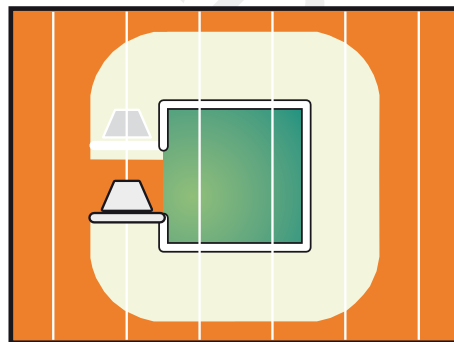


Fig. 355

The field external edge (white line) follows the trajectory of the most external open section valve. When all section valves are closed, the field edge starts from the boom center.



16.5 F5 Resume from pause

Guidance indications to return to job breaking point , previously saved with function **F3 Pause** (par. 16.3).

- 1 In the guidance screen, press **FUNC.**
- 2 Press **F5** to obtain guidance information and enable the return to job breaking point procedure. The fuchsia line **B** in Fig. 356 (which connects the position of the machine to that of the breaking point) shows the direction to be followed to reach the point marked as **A**. The display shows in fuchsia the distance between your position and the breaking point (**C** in Fig. 356).
- 3 Continue driving and make sure that the distance is decreasing: you are reaching the breaking point. When you are close to it, you can see it on the display.
- 4 Once you have reached the position, the value of the distance reaches "zero" (Fig. 357): press **OK** or **ESC** to exit the procedure.



Fig. 356

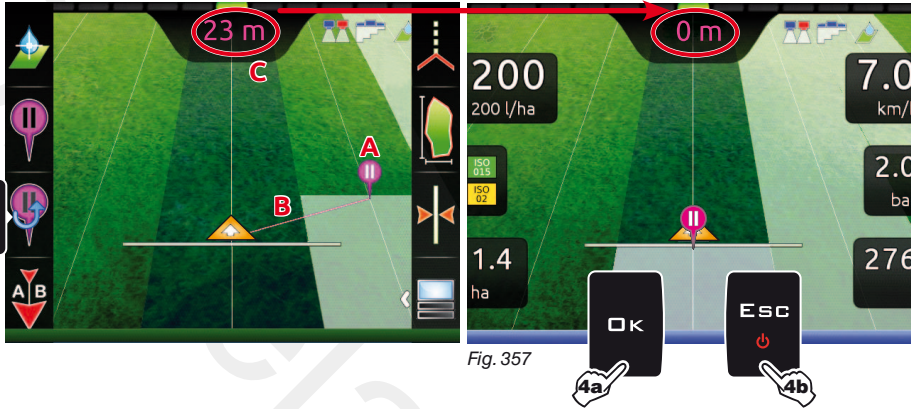
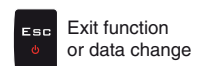
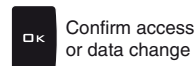


Fig. 357

OK Bravo 400S goes back to displaying guidance information for the job and the symbol is erased.

ESC Bravo 400S goes back to displaying guidance information for the job but the symbol is saved.



16.6 F6 Align

Moves the closest reference track, re-aligning it to the position of the machine. This function is useful when you need to re-align the machine, whilst continuing to drive in the same direction (for example, for corn, sugar cane).



- 1 In the guidance screen, press **FUNC.**
 - 2 Press **F6** to align with the current position.
- The closest reference track (**A** in Fig. 358) moves and becomes aligned with the center of the tractor: all other reference tracks move accordingly. After the alignment, the deviation value **>2.0>** (**B**) becomes **0.0**.



Fig. 358



Fig. 359

Once this function has been used, it is not possible to restore the original reference track.



F1 Enter selected character



F2 Delete selected character



F7 F8 Scroll (LEFT / RIGHT)



F4 F6 Scroll (UP / DOWN)

Value Increase / decrease



Confirm access or data change



Exit function or data change



Par. 74



16.7 F7 New AB

Saves two points A and B on the field, which Bravo 400S uses to draw a line that will act as a reference track (**T0**, Fig. 362) for the current job.

- 1 In the guidance screen, press **FUNC.**
 - 2 Drive along the stretch you wish to use as a reference for the job. Press **F7** to enable the function: the request **Mark A?** will appear on the display (Fig. 360).
 - 3 Press **OK**. The display shows the message **Drive!** (Fig. 361).
 - 4 Keep driving, when you have reached the minimum distance (30 m / 95.5 ft), the request **Mark B?** will appear on the display. Press **OK**.
- The reference track **T0** and all tracks to be followed during the job will appear on the display (Fig. 362).



Fig. 360



Fig. 361

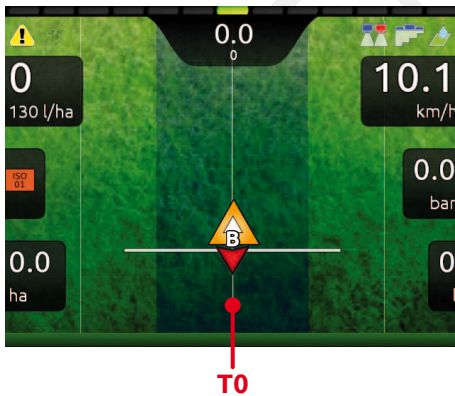


Fig. 362

When this function is used, Bravo 400S deletes the previous reference track **T0** (if present), and prompts the operator to save two NEW points **A** and **B** on the field, which create a NEW reference track.

WARNING:
Points **A** and **B** can be marked only when the vehicle is moving.
The previous track **T0** cannot be restored.

16.8 FB Display

Allows to select different display modes. Includes several functions:

- 1 In the guidance screen, press **FUNC.**
- 2 Press **FB**. A list of options concerning display modes will appear (Fig. 363). Pressing each key will enable the corresponding function:
F2 changes spraying themes (par. 16.8.1);
F4 changes tractor themes (par. 16.8.2);
F6 switches between 2D/3D display mode (par. 16.8.3);
FB switches between daytime/night time display mode (par. 16.8.4);

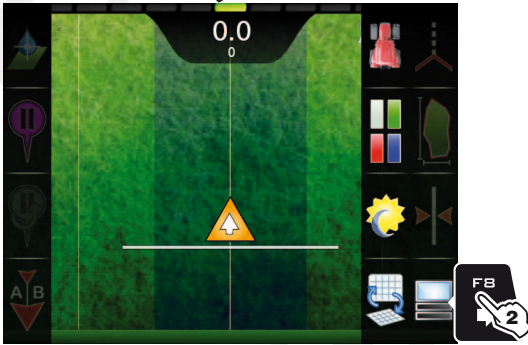


Fig. 363

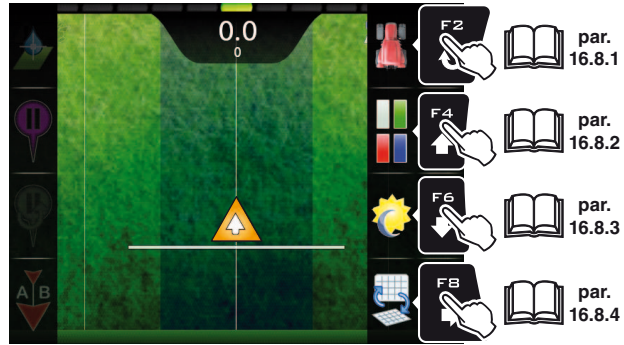


Fig. 364

16.8.1 F2 Tractor themes



- 1 In the guidance screen, press **FUNC.**
- 2 Press **FB** to view the available options.
- 3 Press **F2** in succession to scroll tractor themes.



Fig. 365

TRACTOR THEME 1 (DEFAULT)



Fig. 366

THEME 2



Fig. 367

THEME 3



Fig. 368

THEME 4



Fig. 369

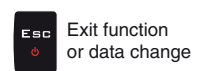
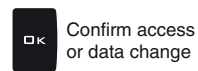
THEME 5



Fig. 370



Value Increase / decrease



16.8.2 F4 Spraying themes



- 1 In the guidance screen, press **FUNC**.
- 2 Press **FB** to view the available options.
- 3 Press **F4** in succession to scroll spraying color combinations.

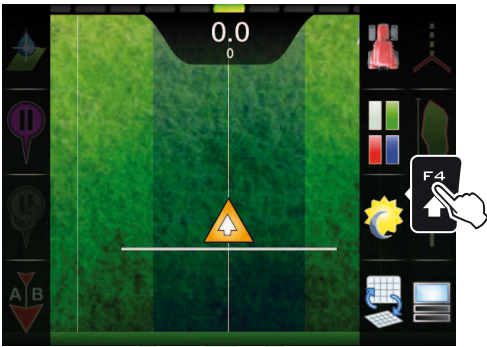


Fig. 371

SPRAYING THEME 1 (DEFAULT)



Fig. 372

THEME 2



Fig. 373

THEME 3



Fig. 374

THEME 4



Fig. 375

THEME 5

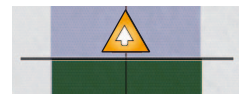


Fig. 376

16.8.3 F6 Daytime/night time display mode



- 1 In the guidance screen, press **FUNC**.
- 2 Press **FB** to view the available options.
- 3 Press **F6** in succession to switch between daytime and night time display mode.

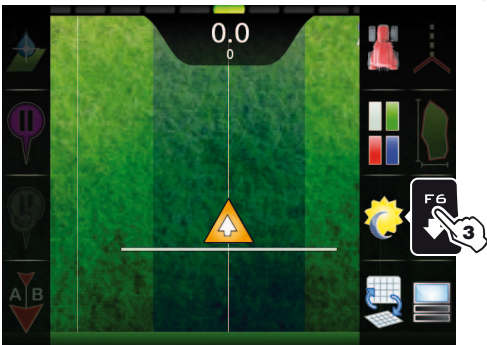


Fig. 377

DAYTIME DISPLAY MODE (DEFAULT)

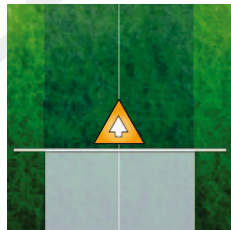


Fig. 378

NIGHT TIME DISPLAY MODE

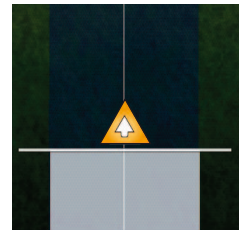


Fig. 379

16.8.4 FB 2D/3D display mode



- 1 In the guidance screen, press **FUNC**.
- 2 Press **FB** to view the available options.
- 3 Press **FB** in succession to switch between 2D and 3D display mode.

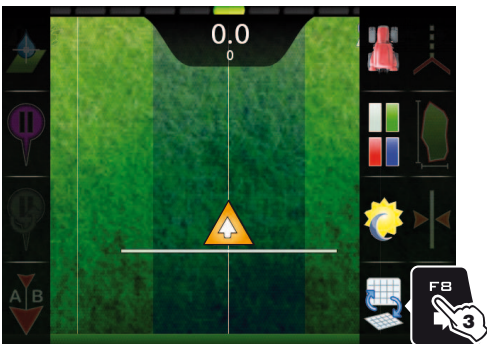


Fig. 380

2D DISPLAY MODE (DEFAULT)

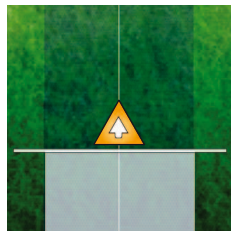


Fig. 381

3D DISPLAY MODE

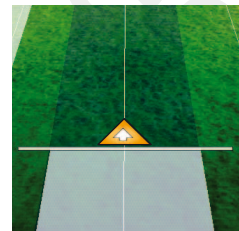
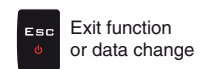
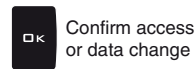



















Fig. 382



17 MAINTENANCE / DIAGNOSTICS / REPAIRS

17.1 Error messages

MESSAGE ON DISPLAY	CAUSE	REMEDY	WORK MODE
Drive! Machine stopped	Main switch ON with machine stopped	<ul style="list-style-type: none"> Start the machine. Move main switch downwards (position OFF) 	Main ON  + AUTO adjustment ON 
Connection to RCU not detected!	Communication problems between monitor and control unit (RCU)	<ul style="list-style-type: none"> Check condition of connection cables (and connectors) between monitor and control unit (par. 5.2). 	--
	The cables are damaged	<ul style="list-style-type: none"> Replace the cable 	--
GPS receiver not connected!	Wrong connection of receiver cable to Bravo 400S	<ul style="list-style-type: none"> Check connection to receiver (par. 5.2 - 5.7) 	--
	The receiver connection cable is damaged	<ul style="list-style-type: none"> Replace the cable 	--
	The receiver is damaged	<ul style="list-style-type: none"> Replace the receiver 	--
Insufficient GPS signal quality!	The position and number of satellites do not allow a suitable driving precision	<ul style="list-style-type: none"> Wait for signal strength to improve 	--
GPS receiver gives invalid data!	The receiver is establishing a connection to the satellites	<ul style="list-style-type: none"> Wait for connection 	--
DGPS correction not available!	DGPS signal unavailable in the working area	<ul style="list-style-type: none"> Disable DGPS correction (par. 10.3.1) 	--
	DGPS connecting	<ul style="list-style-type: none"> Wait for connection 	--
Activate pump! Missing flowrate	Main switch ON with machine stopped but rate at zero	<ul style="list-style-type: none"> Start the pump and move the machine. 	Main ON  + AUTO adjustment ON 
Minimum tank level reached!	Tank level is lower than the set range value	<ul style="list-style-type: none"> Fill the tank (par. 15.3) 	Main ON 
	Minimum value was not set correctly	<ul style="list-style-type: none"> Check set range value (par. 10.1.10). 	
Automatic adjustment locked!	Pressure does not reach set value	<ul style="list-style-type: none"> Increase driving speed 	Main ON  + AUTO adjustment ON 
	Limit was not set correctly	<ul style="list-style-type: none"> Check set limit (par. 10.1.12 - 10.2.2) 	
Decelerate! Pressure too high	The pressure exceeds the maximum level allowed for the nozzle being used	<ul style="list-style-type: none"> Decrease driving speed Adjust the operating pressure so as to respect the previously set limits for nozzles in use. Check set maximum pressure for nozzles in use (par. 10.1.7) 	Main ON 
Accelerate! Insufficient pressure	The pressure does not reach the minimum value for the nozzle in use	<ul style="list-style-type: none"> Increase driving speed Adjust the operating pressure so as to respect the previously set limits for nozzles in use. Check set minimum pressure for nozzle in use (par. 10.1.7) 	Main ON 
Flowmeter out of range!	Rate out of the limits allowed by flowmeter	<ul style="list-style-type: none"> Modify working conditions to suit flowmeter limits (speed, pressure, etc.) Make sure that flowmeter parameters are set correctly (par. 10.1.3) 	Main ON 

MESSAGE ON DISPLAY	CAUSE	REMEDY	WORK MODE
Decelerate! Insufficient flowrate	Flowrate does not reach the value requested for output	<ul style="list-style-type: none"> Decrease driving speed Make sure that flowmeter parameters are set correctly (par. 10.1.3) 	Main ON  + AUTO adjustment ON 
Accelerate! Too high flowrate	The flowrate exceeds the value required for output	<ul style="list-style-type: none"> Increase driving speed Make sure that settings in the Settings Implement menu (boom width, flowmeter, etc. chap. 10.1 - 10.2) are set correctly 	Main ON  + AUTO adjustment ON 
Reduce rotation speed!	RPM exceeds the maximum set value	<ul style="list-style-type: none"> Decrease the rotation speed of the moving part Check the constant set for the rev counter (par. 10.1.9) 	--
Increase rotation speed!	RPM does not reach the minimum value	<ul style="list-style-type: none"> Increase the rotation speed of the moving part Check the constant set for the rev counter (par. 10.1.9) 	Main ON 
Check nozzles wear status!	Difference between measured and calculated flowrate (according to selected nozzle data) higher than set value	<ul style="list-style-type: none"> Check that the set nozzle coincides with the one installed on the boom (par. 10.1.1) Replace nozzles 	Main ON  + AUTO adjustment ON 
Switch box connection not detected!	Communication problems between monitor and switches	<ul style="list-style-type: none"> Check condition of connection cables (and connectors) between monitor and switch box 	--
	The cables are damaged	<ul style="list-style-type: none"> Replace the cable 	
Seletron connection failed!	One or more spraying points do not respond	<ul style="list-style-type: none"> Identify the unrecognized spraying point with the dedicated menu Device status > Status of the Seletron system (par. 10.6) Check that the corresponding spraying point is connected correctly Check condition of harness on the corresponding spraying point 	--
Seletron system error!	Low supply voltage on one or more spraying points	Check battery voltage level	--
		<ul style="list-style-type: none"> Identify the unrecognized spraying point with the dedicated menu Device status > Status of the Seletron system (par. 10.6) Check condition of harness on the corresponding spraying point 	--

17.2 Troubleshooting

FAULT	CAUSE	REMEDY
The display does not switch on	No power supply	• Check power supply connection
	Computer is OFF	• Press the ON key
Valve controls take no effect	Valves not connected	• Connect the connectors
One valve does not open	No power supply to valve	• Check valve electric connection and operation
Speed reading is unstable	Job start procedure was launched at a point too far from the field to be sprayed	• Start a new job (par. 12.5) closer to the field.
Output volume readout inaccurate	Wrong setup	• Check boom setup (par. 10.1.2 - 10.2.1) • Check the setup of the flowmeter constant (par. 10.1.3) • Check pressure sensor full scale setting (par. 10.1.5)
Distance traveled count displayed does not match actual distance covered	Wrong setup	• Check boom setup (par. 10.1.2 - 10.2.1) • Check implement geometry (par. 10.1.14 - 10.1.15 - 10.2.3 - 10.2.4) • Check tractor geometry (par. 10.3.4)
Sprayed fluid count displayed does not match litres/gal actually sprayed	Wrong setup	• Check the setup of the flowmeter constant (par. 10.1.3) • Check selected nozzle configuration (par. 10.1.1 - par. 12.5)
Unable to reach output volume value set for the automatic operation	Wrong setup	• Check spray rate setup (par. 12.5 - 16.1) • Check the setup of the boom width (par. 10.1.2)
	System not adequately sized to provide required rate	• Check maximum pressure valve setting • Make sure control valve is adequate for specific system
	Control valve malfunction	• Check valve operation
Instantaneous pressure readout inaccurate	Wrong setup	• Check full scale setup for pressure sensor (par. 10.1.5)
	Pressure sensor not calibrated	• Perform the calibration (par. 10.1.13)
	Pressure sensor wrong installation	• Check connections to pressure sensor
Instantaneous pressure is not displayed	Wrong setup	• Check pressure sensor setting (par. 10.1.5)
	Computer does not receive signals from pressure sensor	• Check connections to pressure sensor
	Pressure sensor wrong installation	• Check connections to pressure sensor
Rpm readout inaccurate	Wrong setup	• Check rpm sensor constant setting (par. 10.1.9)
Rpm value not displayed	Monitor does not receive signals from RPM sensor	• Check connections to RPM sensor
	Rpm sensor wrong installation	• Check connections to RPM sensor
Pump failure alarm permanently active	Monitor does not receive signals from Pump Protector sensor	• Check connections to Pump Protector sensor

17.3 Cleaning rules

- Clean only with a soft wet cloth.
- DO NOT use aggressive detergents or products.
- DO NOT aim water jets directly at monitor and control unit.

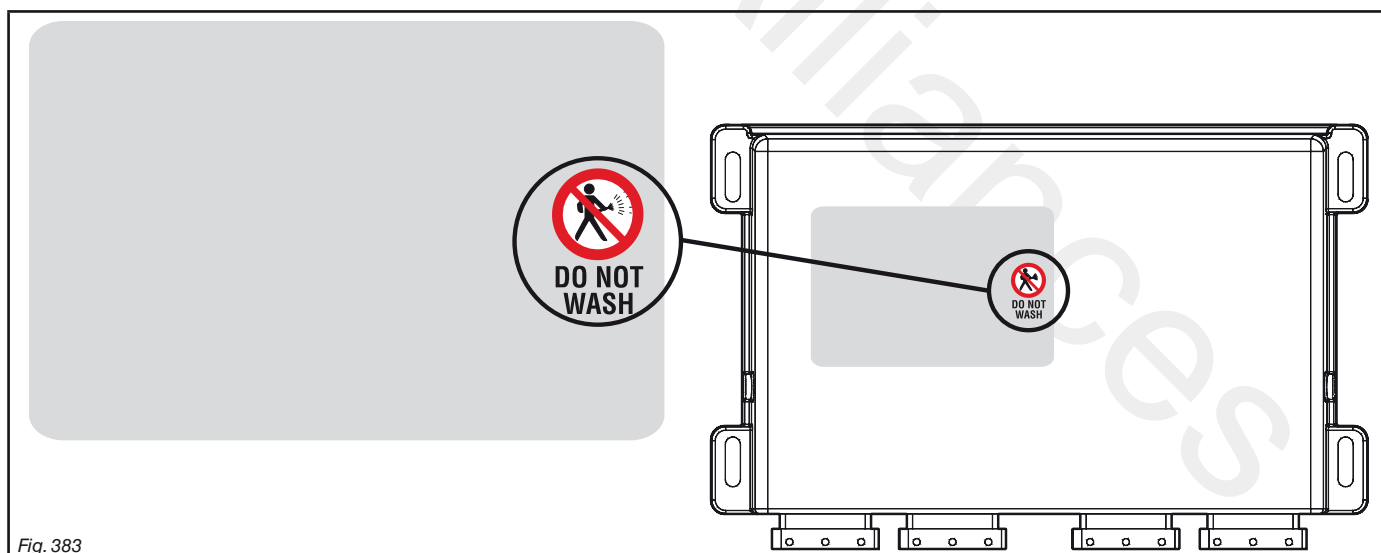


Fig. 383

18 TECHNICAL DATA

Description	Bravo 400S
Display	LCD 5,7", 65000 colors, 500 cd/m ²
Rated supply voltage	12 Vdc (9 ÷ 15 Vdc)
Consumption (valves excluded)	monitor: 0,4 A / Seletron RCU: 0,6 A / Hydraulic RCU: 1,5 A
Working temperature	0 °C ÷ 45 °C +32 °F ÷ +113 °F
Storage temperature	-20 °C ÷ 45 °C -4 °F ÷ +113 °F
Digital inputs	for open collector sensors: max 2000 imp*/s
Analog input	4 ÷ 20 mA
Weight (without cables)	monitor: 1567 g (Bravo code 4674A9D20.950) Seletron RCU: 1143 g / Hydraulic RCU: 1143 g
SD card reader	Yes
2 USB 2.0 ports	HOST
Protection against polarity inversion	•
Protection against short-circuit	•

18.1 The data and unit of measurement shown

Implement - SPRAYER (SELETRON)											
Menu	Data	Min.	Max.	UoM	DEFAULT	Other values that can be set / Notes					
	Number of nozzles for each spraying point	--	--	no.	1	2, 4	Selection during guided setup				
Spray spots configurations	Spraying point 1				ISO01						
		Nozzle A	--	--	--	Disabled					
		Nozzle B	--	--	--	Disabled					
		Nozzle C	--	--	--	Disabled					
		Nozzle D	--	--	--	Disabled					
	Spraying point 2				ISO02						
		Nozzle A	--	--	--	Disabled					
		Nozzle B	--	--	--	Disabled					
		Nozzle C	--	--	--	Disabled					
		Nozzle D	--	--	--	Disabled					
	Spraying point 3				ISO03						
		Nozzle A	--	--	--	Disabled					
		Nozzle B	--	--	--	Disabled					
		Nozzle C	--	--	--	Disabled					
		Nozzle D	--	--	--	Disabled					
	Spraying point 4				Disabled	ISO01	ISO015	ISO02	ISO025	ISO03	ISO04
	Spraying point 5				Disabled	ISO05	ISO06	ISO08	ISO10	ISO15	ISO20
	Spraying point 6				Disabled	A	B	C	D	E	F
	Spraying point 7				Disabled						
	Spraying point 8				Disabled						
Spraying point 9				Disabled							
Spraying point 10				Disabled							
Spraying point 11				Disabled							
Spraying point 12				Disabled							
Spraying point 13				Disabled							
Spraying point 14				Disabled							
Spraying point 15				Disabled							
Spraying point 16				Disabled							
Spraying point 17				Disabled							
Spraying point 18				Disabled							
Spraying point 19				Disabled							
Spraying point 20				Disabled							
Boom settings	Spray spots spacing	1	1000	cm	50 cm						
	Sections number	0.39	393.70	inches	19.68 inches						
	Section 1 ÷ 13	1	50	no.	4		Number of spraying points for each section				
Flowmeter	Type	--	--	--	Orion 462xxA4xxxx		Orion 4621xA0xxxx, Orion 4621xA1xxxx, Orion 4621xA2xxxx, Orion 4621xA3xxxx, Orion 4622xA5xxxx, Orion 4622xA6xxxx, Wolf 462x2xxx, Wolf 462x3xxx, Wolf 462x4xxx, Wolf 462x5xxx, Wolf 462x7xxx, Other				
	Constant	1	32000	pls*/l	--						
		4	32000	pls*/gal	--						
	Minimum flowrate	0.1	999.9	l/min	--		Fixed settings for each flowmeter except Other				
Filling flowmeter	Maximum flowrate	0.1	999.9	GPM	--						
		0.1	999.9	l/min	--						
	Activation status	--	--	--	Disabled	ENABLED					
	Type	--	--	--	Orion 462xxA4xxxx	Orion 4622xA5xxxx, Orion 4622xA6xxxx, Wolf 462x4xxx, Wolf 462x5xxx, Wolf 462x7xxx, Other					
Pressure sensor	Constant	1	32000	pls*/l	--						
		4	32000	pls*/gal	--						
	Minimum flowrate	0.1	999.9	l/min	--		Fixed settings for each flowmeter except Other				
	Maximum flowrate	0.1	999.9	GPM	--						
Pressure sensor	Activation status	--	--	--	Disabled	Enabled					
	Type	--	--	--	466113.200	466113.500, Other					
	Maximum pressure	0.1	150.0	bar	--		Fixed settings for each sensor except Other				
		1	2175	PSI	--						

* pls = pulse

>>> 18.1 The data and unit of measurement shown

Implement - SPRAYER (SELETRON)

Menu	Data	Min.	Max.	UoM	DEFAULT	Other values that can be set / Notes	
Valves	Type	--	--	--	3 ways	2 ways, None Selection during guided setup	
	Main valve				Automatic closing of sections valves	Enabled Disabled Selection during guided setup	
	Pressure regulating valve	Switching time	0.1	1.0	s	1.0 s	
		Regulation direction	--	--	--	Standard	Reverse
	Section valves	Type	--	--	--	2 ways	Automatic selection during guided setup
		Shut-off time	0.1	1.0	s	0.6 s	
		Switch-on time	0.1	1.0	s	0.2 s	
Nozzles data	ISO01	--	--	l/min	0.40 l/min		
		--	--	GPM	0.10 GPM		
	ISO015	--	--	l/min	0.60 l/min		
		--	--	GPM	0.15 GPM		
	ISO02	--	--	l/min	0.80 l/min		
		--	--	GPM	0.20 GPM		
	ISO025	--	--	l/min	1.00 l/min		
		--	--	GPM	0.25 GPM		
	ISO03	--	--	l/min	1.20 l/min		
		--	--	GPM	0.30 GPM		
	ISO04	--	--	l/min	1.60 l/min		
		--	--	GPM	0.40 GPM		
	ISO05	--	--	l/min	2.00 l/min	ISO nozzles - cannot be modified	
		--	--	GPM	0.50 GPM		
	ISO06	--	--	l/min	2.40 l/min		
		--	--	GPM	0.60 GPM		
	ISO08	--	--	l/min	3.20 l/min		
		--	--	GPM	0.80 GPM		
	ISO10	--	--	l/min	4.00 l/min		
		--	--	GPM	1.00 GPM		
Nozzles data	ISO15	--	--	l/min	6.00 l/min		
		--	--	GPM	1.50 GPM		
	ISO20	--	--	l/min	8.00 l/min		
		--	--	GPM	2.00 GPM		
	Pressure		--	--	bar	3.0 bar	
			--	--	PSI	40 PSI	
	A	Flowrate	0.10	10.00	l/min	1.00 l/min	
			0.03	2.6	GPM	0.26 GPM	
	B	Flowrate	0.10	10.00	l/min	2.00 l/min	
			0.03	2.6	GPM	0.53 GPM	
	C	Flowrate	0.10	10.00	l/min	3.00 l/min	
			0.03	2.6	GPM	0.79 GPM	
	D	Flowrate	0.10	10.00	l/min	4.00 l/min	User nozzles - customizable
			0.03	2.6	GPM	1.06 GPM	
E	Flowrate	0.10	10.00	l/min	5.00 l/min		
		0.03	2.6	GPM	1.32 GPM		
F	Flowrate	0.10	10.00	l/min	6.00 l/min		
		0.03	2.6	GPM	1.59 GPM		
Pressure		0.1	50.0	bar	5.0 bar		
		1.45	725	PSI	70 PSI		
Minimum pressure		0.1	50.0	bar	Default ISO nozzles: 1.0 ÷ 5.0 bar		
		1.45	725	PSI	15 ÷ 70 PSI		
Maximum pressure		0.1	50.0	bar	Default user nozzles: 2.0 ÷ 10.0 bar		
		1.45	725	PSI	30 ÷ 145 PSI		
Wheel sensor	Constant	0.01	2000.00	cm/pls*	38.33 cm/pls*		
		0.01	780.00	inch/pls*	15.09 inch/pls*		
Rev counter	Activation status	--	--	--	Disabled	Enabled	
	Constant	1	999	pls*/rev**	100 pls*/rev**		
	Minimum rotation speed	1	10000	rpm	100 rpm		
	Maximum rotation speed	1	10000	rpm	500 rpm		
Tank	Capacity	1	99999	l	2000 l		
	Reserve level	1	25000	gal	528 gal		
		1	2000	l	150 l		
Alarms	Nozzle wear check	--	--	--	Disabled	Enabled Visible ONLY with Pressure sensor enabled	
	Nozzles alarms	Nozzle wear limit percentage	1	50	%	10 %	Visible ONLY with Pressure sensor enabled
		Minimum pressure alarm	--	--	--	Disabled	Enabled
	Flowmeter alarms	Maximum pressure alarm	--	--	--	Disabled	Enabled
		Minimum flowrate alarm	--	--	--	Disabled	Enabled
	Rev counter alarms	Maximum flowrate alarm	--	--	--	Disabled	Enabled
		Minimum rotation speed alarm	--	--	--	Disabled	Enabled
		Maximum rotation speed alarm	--	--	--	Disabled	Enabled

* pls = pulse
** rev = revolution

>>> 18.1 The data and unit of measurement shown

Implement - SPRAYER (SELETRON)

Menu	Data	Min.	Max.	UoM	DEFAULT	Other values that can be set / Notes	
Working parameters	Spraying limits	Spraying speed limit	--	--	--	Disabled	Enabled
		Minimum spraying speed	0.4	99.9	km/h	1.0 km/h	
			0.2	99.9	mph	0.6 mph	
		Regulation pressure limit	--	--	--	Disabled	Enabled
			0.1	99.9	bar	1.0 bar	
		Minimum regulation pressure	1	1449	PSI	15 PSI	
			0.25	4.00	--	1.00	
		Flowrate correction factor					
			0	100	%	100 %	
		Sections overlapping limit					
		0	100	%	0 %		
	Perimeter overlapping limit						
Automatic section control	Spray closing delay	-5.0	5.0	m	0.0 m		
		-16.00	16.00	ft	0.00 ft		
		-5.0	5.0	m	0.0 m		
	Spray opening advance	-16.00	16.00	ft	0.00 ft		
Guidance	Steering radius	0.0	20.0	m	0.0 m		
		0.00	65.00	ft	0.00 ft		
3-point implement geometry settings	Implement upper view	Distance between connection point and application point	0.00	20.00	m	0.50 m	
			0.00	64.00	ft	1.64 ft	
	Implement rear view	Offset between connection point and application point	-20.00	20.00	m	0.00 m	System with 3-point hitch , selected during guided setup
			-64.00	64.00	ft	0.00 ft	
		0.50	90.00	m	20.00 m		
	Implement width	0.50	290.00	ft	65.62 ft		
Towed implement geometry	Implement upper view	Distance between implement's rear axle and the application point	0.00	20.00	m	0.50 m	
			0.00	64.00	ft	1.64 ft	
		Distance between connection point and implement's rear axle	0.00	20.00	m	5.00 m	
			0.00	64.00	ft	16.40 ft	
			0.50	5.00	m	2.00 m	System with Towing hitch , selected during guided setup
		Distance between tractor's wheels	0.50	15.00	ft	6.56 ft	
			-20.00	20.00	m	0.00 m	
		Offset between connection point and application point	-64.00	64.00	ft	0.00 ft	
Implement rear view	Implement width	0.50	90.00	m	20.00 m		
		0.50	290.00	ft	65.62 ft		

Implement - GPS GUIDANCE MONITOR

Menu	Data	Min.	Max.	UoM	DEFAULT	Other values that can be set / Notes	
Sections configuration	Sections number	1	13	n°	1		
	Section 1 ÷ 13	1.00	50.00	m	20.00 m	Width of each section	
		2.00	164.04	ft	6.56 ft		
Working parameters	Sections overlapping limit	0	100	%	100 %		
	Perimeter overlapping limit	0	100	%	0 %		
	Spray closing delay	-5.0	5.0	m	0.0 m		
		-16.00	16.00	ft	0.00 ft		
	Spray opening advance	-5.0	5.0	m	0.0 m		
		-16.00	16.00	ft	0.00 ft		
Steering radius		0.0	20.0	m	0.0 m		
		0.00	65.00	ft	0.00 ft		
3-point implement geometry settings	Implement upper view	Distance between connection point and application point	0.00	20.00	m	0.50 m	
			0.00	64.00	ft	1.64 ft	
	Implement rear view	Offset between connection point and application point	-20.00	20.00	m	0.00 m	System with 3-point hitch , selected during guided setup
			-64.00	64.00	ft	0.00 ft	
		0.50	90.00	m	20.00 m		
	Implement width	0.50	290.00	ft	65.62 ft		
Towed implement geometry	Implement upper view	Distance between implement's rear axle and the application point	0.00	20.00	m	0.50 m	
			0.00	64.00	ft	1.64 ft	
		Distance between connection point and implement's rear axle	0.00	20.00	m	5.00 m	
			0.00	64.00	ft	16.40 ft	
			0.50	5.00	m	2.00 m	System with Towing hitch , selected during guided setup
		Distance between tractor's wheels	0.50	15.00	ft	6.56 ft	
			-20.00	20.00	m	0.00 m	
		Offset between connection point and application point	-64.00	64.00	ft	0.00 ft	
Implement rear view	Implement width	0.50	90.00	m	20.00 m		
		0.50	290.00	ft	65.62 ft		

CONTINUES >>>

>>> 18.1 The data and unit of measurement shown

Tractor							
Menu	Data	Min.	Max.	UoM	DEFAULT	Other values that can be set / Notes	
A100 Receiver	DGPS	--	--	--	Disabled	Receiver selected during guided setup	
	PDOP alarm	1.0	10.0	--	4.0		
NMEA Receiver	DGPS	--	--	--	Enabled	Receiver selected during guided setup	
	HDOP alarm	1.0	10.0	--	4.0		
Tractor advanced settings	Camera	--	--	--	None	1, 2, Both	
Tractor geometry settings	Tractor upper view	Distance between tractor's rear axle and GPS antenna	-20.00	20.00	m	0.00 m	
			-64.00	64.00	ft	0.00 ft	
	Tractor rear view	Distance between rear tractor's wheels	0.50	10.00	m	3.00 m	
			0.50	35.00	ft	9.84 ft	
	Tractor front view	Horizontal distance between connection point and GPS antenna	-8.00	8.00	m	0.00 m	
			-25.00	25.00	ft	0.00 ft	
	Tractor side view	Distance between front tractor's wheels	0.50	10.00	m	2.00 m	
			0.50	35.00	ft	6.56 ft	
	Tractor rear view	Vertical distance between rear connection point and tractor's rear wheels axis	0.00	20.00	m	0.00 m	
			0.00	64.00	ft	0.00 ft	
	Tractor front view	Distance between tractor's front axle and rear axle	0.50	20.00	m	2.00 m	
			0.50	64.00	ft	6.56 ft	
	Tractor side view	Vertical distance between front connection point and tractor's front wheels axis	0.50	20.00	m	6.00 m	
			0.50	64.00	ft	19.69 ft	
Tractor rear view	GPS antenna height from tractor's rear axle	0.00	20.00	m	0.00 m		
		0.00	64.00	ft	0.00 ft		
Tractor front view	Rear axle height from the ground	0.20	5.00	m	1.50 m		
		0.20	15.00	ft	4.92 ft		
Steering angle		0	90	°	30 °		

User						
Menu	Data	Min.	Max.	UoM	DEFAULT	Other values that can be set / Notes
Acoustic alarms		--	--	--	Disabled	Enabled
Acustica low priority alarms		--	--	--	Disabled	Enabled
Acoustic info		--	--	--	Disabled	Enabled
Steering warning		--	--	--	Disabled	Enabled

General options						
Menu	Data	Min.	Max.	UoM	DEFAULT	Other values that can be set / Notes
Language		--	--	--	English	Cesky, Deutsch, Español, Français, Magyar, Italiano, Polski, Português, Русский
Unit of measurement		--	--	--	Metric	US, Turf
Date and time GPS updating		--	--	--	Enabled	Disabled
Timezone		-12	14	h	0 h	Visible ONLY with Date and time GPS updating enabled
Date and time		--	--	--	--	Visible ONLY with Date and time GPS updating disabled

Work data - SPRAYER (SELETRON)			
Data		UoM	
Applied area	ha	ac	ksqft
Applied quantity	l	gal	gal
Average application rate	l/ha	GPA	GPK
Nozzles	--	--	--
Calculated area	ha	ac	ksqft
Working time	hh:mm	hh:mm	hh:mm
Application time	hh:mm	hh:mm	hh:mm
Average productivity	ha/h	ac/h	ksqft/h
Job start date	dd/mm/yyyy	dd/mm/yyyy	dd/mm/yyyy
Job start time	hh:mm	hh:mm	hh:mm

Work data - GPS GUIDANCE MONITOR			
Data		UoM	
Applied area	ha	ac	ksqft
Calculated area	ha	ac	ksqft
Working time	hh:mm	hh:mm	hh:mm
Application time	hh:mm	hh:mm	hh:mm
Average productivity	ha/h	ac/h	ksqft/h
Job start date	dd/mm/yyyy	dd/mm/yyyy	dd/mm/yyyy
Job start time	hh:mm	hh:mm	hh:mm

END 18.1 The data and unit of measurement shown

19 END-OF-LIFE DISPOSAL

Dispose of the system in compliance with the established legislation in the country of use.

20 GUARANTEE TERMS

1. ARAG s.r.l. guarantees this apparatus for a period of 360 days (1 year) from the date of sale to the client user (date of the goods delivery note).
The components of the apparatus, that in the unappealable opinion of ARAG are faulty due to an original defect in the material or production process, will be repaired or replaced free of charge at the nearest Assistance Center operating at the moment the request for intervention is made. The following costs are excluded:
 - disassembly and reassembly of the apparatus from the original system;
 - transport of the apparatus to the Assistance Center.
2. The following are not covered by the guarantee:
 - damage caused by transport (scratches, dents and similar);
 - damage due to incorrect installation or to faults originating from insufficient or inadequate characteristics of the electrical system, or to alterations resulting from environmental, climatic or other conditions;
 - damage due to the use of unsuitable chemical products, for spraying, watering, weedkilling or any other crop treatment, that may damage the apparatus;
 - malfunctioning caused by negligence, mishandling, lack of know how, repairs or modifications carried out by unauthorized personnel;
 - incorrect installation and regulation;
 - damage or malfunction caused by the lack of ordinary maintenance, such as cleaning of filters, nozzles, etc.;
 - anything that can be considered to be normal wear and tear.
3. Repairing the apparatus will be carried out within time limits compatible with the organisational needs of the Assistance Center.
No guarantee conditions will be recognized for those units or components that have not been previously washed and cleaned to remove residue of the products used.
4. Repairs carried out under guarantee are guaranteed for one year (360 days) from the replacement or repair date.
5. ARAG will not recognize any further expressed or intended guarantees, apart from those listed here.
No representative or retailer is authorized to take on any other responsibility relative to ARAG products.
The period of the guarantees recognized by law, including the commercial guarantees and allowances for special purposes are limited, in length of time, to the validities given here.
In no case will ARAG recognize loss of profits, either direct, indirect, special or subsequent to any damage.
6. The parts replaced under guarantee remain the property of ARAG.
7. All safety information present in the sales documents regarding limits in use, performance and product characteristics must be transferred to the end user as a responsibility of the purchaser.
8. Any controversy must be presented to the Reggio Emilia Law Court.

Only use genuine ARAG accessories or spare parts to make sure manufacturer guaranteed safety conditions are maintained in time. Always refer to ARAG spare parts catalogue.

Cleveland Alliances

D20258_GB-m00 07/2012



42048 RUBIERA (Reggio Emilia) - ITALY
Via Palladio, 5/A

Tel. +39 0522 622011
Fax +39 0522 628944

<http://www.aragnet.com>
info@aragnet.com